

符合RoHS指令要求  
CONFORM TO RoHS INSTRUCTIONS

图号/DWG NO.  
28HSM51-D0520-002

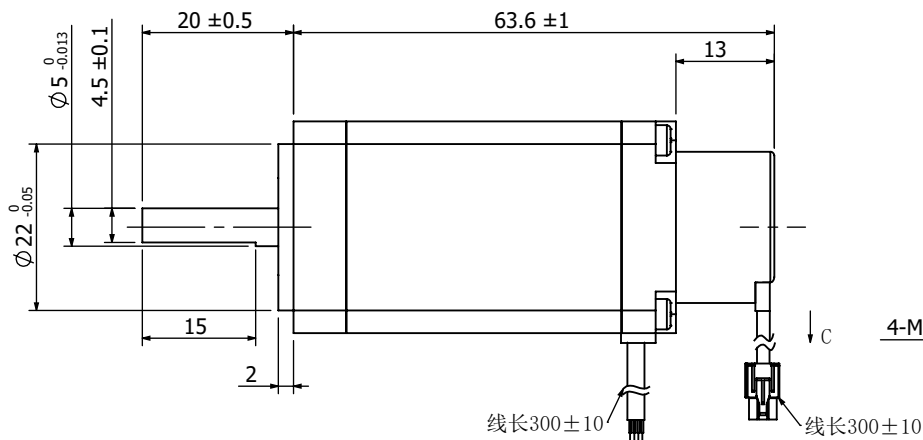

接线图/WIRING DIAGRAM

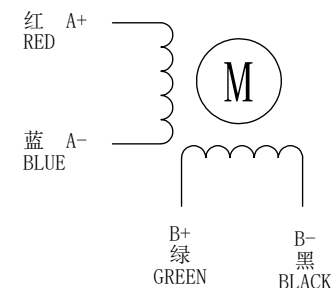

电机特性参数/ELECTRICAL PARAMETER

步距角/STEP ANGLE	1.8° ± 5%
相数/NO. OF PHASES	2
额定电压/RATED VOLTAGE	3.36V
额定电流/RATED CURRENT	1.2A
电阻/RESISTANCE	2.8ohm ± 10% AT 25°C
电感/INDUCTANCE	2.4mH ± 20% AT 1kHz, 1Vrms
保持力矩/HOLDING TORQUE	0.13 N.M
运行力矩/(AT —PPS) RUNNING TORQUE (AT —PPS)	——以上/MIN (——V. DC, ——A/相(PHASE), ——相励磁/EX)
绝缘耐压/DIELECTRIC STRENGTH	500V A.C 1分钟/MINUTE
绝缘电阻/INSULATION RESISTANCE	100MΩ 以上/MIN.
绝缘等级/INSULATION CLASS	CLASS B
温度上升/TEMPERATURE RISE	80K MAX.
转子惯量/ROTOR INERTIA	0.18kg. cm <sup>2</sup>
重量/WEIGHT	约/APPROX. 220克/g
允许轴向负载/ALLOWABLE THRUST LOAD	5N
允许径向负载/ALLOWABLE RADIAL LOAD	25N(轴端/ON THE SHAFT END)
运行环境温度/OPERATION AMBIENT TEMP.	-20°C —— +50°C
运行环境湿度/OPERATION AMBIENT HUM.	15% —— 90%



C向:

1000线编码器出线定义						
序号	1	4	2	5	3	6
定义	EA+	EA-	EB+	EB-	5V	GND
线色	黑	蓝	绿	黄	红	白

励磁顺序(2相励磁) VS. 旋转方向  
EXCITING SEQUENCE (TWO PHASES)  
VS. DIRECTION OF ROTATION

	STEP	A+	B+	A-	B-
CW	1	+	+	-	-
	2	-	+	+	-
	3	-	-	+	+
	4	+	-	-	+
					CCW

从安装面看为顺时针方向  
CLOCKWISE VIEW FROM MOUNTING SIDE

已受控

CONFIRMED&ACCEPTED BY CUTOMER (客户确认&接受)									
COMPANY CHOP&SIGNATURE (盖章&签名)									
一般公差 TOLERANCE	±0.3/±3°	版本 REV.	年月日 DATE	变更番号 ECR NO.	变更内容 REVISIONS	设计 BY	备注 NOTE	REV.	A
设计/DESIGNED	陈力 48P	比例 SCALE		型号/MODEL				三维图 THIRD ANGLE PROJECTION	
审核/CHECKED		单位 UNIT	mm	28AM013EC					
深圳锐特机电技术有限公司								页 SHEET	1/1

备注(NOTE):

- 额定电流, 两相同时通电/AT RATED CURRENT, TWO PHASES ON.
- 热阻法: 电机安装在84\*84\*T5的铝板上, 电机线圈两端通额定电压, OPSS /MEASURED BY RESISTANCE METHOD. MOUNT WITH ALUMINUM HEAT SINK 84\*84\*T5 AT TWO WINDING BE EXCITED BY RATED VOLTAGE, OPSS, 2PHASE ON.
- 寿命测试条件: 整步, 运行速度为500PPS, 轴承的表面温度不超过70° C LIFE TEST CONDITION: 2PHASE EXCITING, FULL STEP, AT 500PPS. STARTING PULSE, BEARING TEMPERATURE SHOULD BE 70° C MAX.