

符合RoHS指令要求
CONFORM TO RoHS INSTRUCTIONS

图号/DWG NO.
42HS40-D0524-001

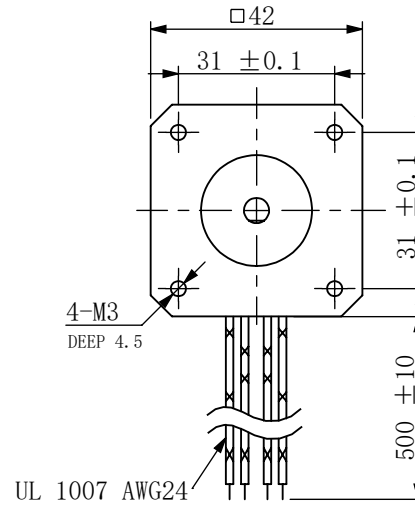

接线图/WIRING DIAGRAM

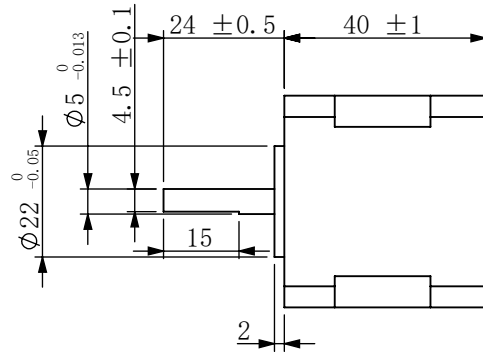
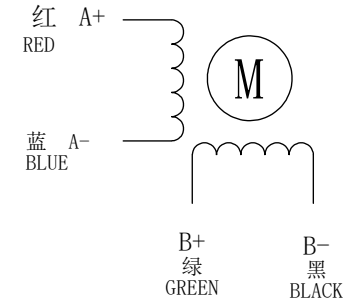

电机特性参数/ELECTRICAL PARAMETER

步距角/STEP ANGLE	1.8° ±5%
相数/NO. OF PHASES	2
额定电压/RATED VOLTAGE	3.12V
额定电流/RATED CURRENT	1.2A
电阻/RESISTANCE	2.6ohm±10% AT25°C
电感/INDUCTANCE	5.1mH±20% AT 1kHz, 1Vrms
保持力矩/HOLDING TORQUE	0.2N.m
运行力矩/(AT —PPS) RUNNING TORQUE(AT —PPS)	——以上/MIN (——V.DC, ——A/相(PHASE), ——相励磁/EX)
绝缘耐压/DIELECTRIC STRENGTH	500V A.C 1分钟/MINUTE
绝缘电阻/INSULATION RESISTANCE	100MΩ 以上/MIN.
绝缘等级/INSULATION CLASS	CLASS B
温度上升/TEMPERATURE RISE	80K MAX.
转子惯量/ROTOR INERTIA	57g. cm²
重量/WEIGHT	约/APPROX. 289克/g
允许轴向负载/ALLOWABLE THRUST LOAD	3N
允许径向负载/ALLOWABLE RADIAL LOAD	20N(轴端/ON THE SHAFT END)
运行环境温度/OPERATION AMBIENT TEMP.	-20°C——+50°C
运行环境湿度/OPERATION AMBIENT HUM.	15%——90%

励磁顺序(2相励磁) VS. 旋转方向
EXCITING SEQUENCE(TWO PHESSES)
VS. DIRECTION OF ROTATION

	STEP	A+	B+	A-	B-
CW ↓	1	+	+	-	-
	2	-	+	+	-
	3	-	-	+	+
	4	+	-	-	+
					↑ CCW

从安装面看为顺时针方向
CLOCKWISE VIEW FROM MOUNTING SIDE

已受控

CONFIRMED&ACCEPTED BY COTUMER (客户确认&接受)									
COMPANY CHOP&SIGNATURE (盖章&签名)									
一般公差 TOLERANCE	±0.3/±3°	版本 REV.	年月日 DATE	变更番号 ECR NO.	变更内容 REVISIONS	设计 BY	备注 NOTE	REV.	A
设计/DESIGNED	张子卿	比例 SCALE		型号/MODEL	42A02	三维图 THIRD ANGLE PROJECTION			
审核/CHECKED	潘国强	单位 UNIT	mm	深圳锐特机电技术有限公司				页 SHEET	1/1

备注(NOTE):
1. 额定电流, 两相同时通电/AT RATED CURRENT, TWO PHASES ON.
2. 热阻法: 电机安装在84*84*T5的铝板上, 电机线圈两端通额定电压, OPPS /MEASURED BY RESISTANCE METHOD. MOUNT WITH ALUMINUM HEAT SINK 84*84*T5 AT TWO WINDING BE EXCITED BY RATED VOLTAGE, OPPS, 2PHASE ON.
3. 寿命测试条件: 整步, 运行速度为500PPS, 轴承的表面温度不超过70° C LIFE TEST CONDITION: 2PHASE EXCITING, FULL STEP, AT 500PPS. STARTING PULSE, BEARING TEMPERATURE SHOULD BE 70° C MAX.