

Digital Stepper Driver 3R130

User Manual

Shenzhen Rtelligent Mechanical Electrical Technology Co.,Ltd

Contents

1. Product overview.....	1
2. Application environment and installation.....	2
2.1 Environmental requirement.....	2
2.2 Driver installation dimensions.....	2
2.3 Driver installation requirements.....	3
3. Driver port and connection.....	3
3.1 Port function description.....	3
3.2 Power supply input.....	4
3.3 Motor connection.....	4
3.4 Control signal connection.....	5
3.4.1 PUL, DIR Port: connection for pulse command.....	5
3.4.2 ENA port: enable/disable.....	5
3.4.3 Input IO signal: IN1, IN2.....	5
3.4.4 Output IO signal: ALM, RDY.....	5
3.4.5 Examples for pulse enable signal connection.....	5
4. The setting of DIP switches and operating parameters.....	7
4.1 The setting of current.....	7
4.2 The setting of pulse per revolution.....	8
4.3 Filter selection.....	8
4.4 Bandwidth selection.....	9
5. Driver working status LED indication.....	9
6. Common faults and troubleshooting.....	9
7. Guarantee clause.....	11

1. Product overview

Thank you for choosing Rtelligent R series digital stepper driver.

R series stepper driver, which surpasses the performance of common analog stepper driver comprehensively based on the new 32-bit DSP platform developed by TI, and adopting the micro-stepping technology and PID current control algorithm design. The R series stepper drivers have the features of low noise, low vibration, low heating and high-speed high torque output, it is suitable for most stepper motors by integrated with the micro-stepping technology.

3R130 driver has built-in pulse command S-type acceleration/deceleration function and limit frequency optional function, which is set by DIP switches.

In addition, you can select the current and subdivision through the DIP switch. There are 16 subdivisions and 16 current selections. It has over-voltage, under-voltage, and over-current protection. Its input and output control signals are optically isolated.

Power supply	110 - 230 VAC
Output Current	Up to 7.0 amps (peak value)
Current control	PID current control algorithm
Micro-stepping settings	DIP switch settings, 16 options
Speed range	Use the suitable motor, up to 3000rpm
Resonance suppression	Automatically calculate the resonance point and inhibit the IF vibration
Parameter adaption	Automatically detect the motor parameter when driver initialize, optimize the controlling performance
Pulse mode	Direction & pulse, CW/CCW double pulse
Pulse filtering	2MHz digital signal processing filter
Neutral current	Automatically halve the current after the motor stopping

We hope that our products with excellent performance can help you to complete the sports control program successfully.

Please read this technical manual before using the products.

2. Application environment and installation

2.1 Environmental requirement

Item	Rtelligent 3R130
Installation environment	Avoid dust, oil and corrosive environment
Vibration	0.5G (4.9m/s ²) Max
Operating temperature/humidity	0°C ~ 45°C / 90% RH or less (no condensation)
Storage and transportation temperature:	-10°C ~ 70°C
Cooling	Natural cooling / away from the heat source
Waterproof grade	IP54

2.2 Driver installation dimensions

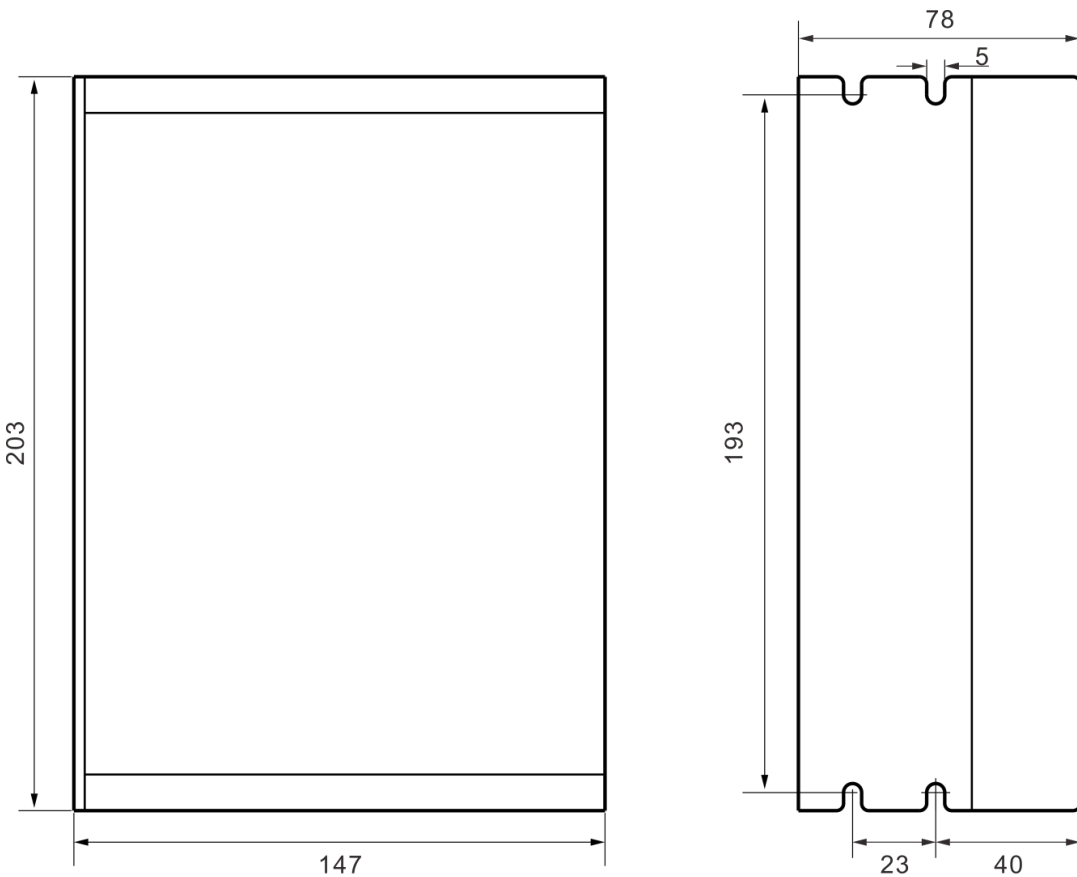

2.3 Driver installation requirements

Please install the driver vertically or horizontally, with its front facing forward, top facing upward to facilitate cooling.

During assembly, avoid drillings and other foreign matters falling inside the driver.

During assembly, please use M3 screw to fix.

When there is vibration source (such as a driller) close to the installation position, please use a vibrating absorber or a vibration resistant rubber gasket.

When multiple drivers are installed in the control cabinet, please pay attention to reserve enough space for sufficient heat dissipation. If necessary, you can configure cooling fans to ensure good heat dissipation conditions in the control cabinet.

3. Driver port and connection

3.1 Port function description

Function	Grade	Definition	Remarks	
Power supply input port	AC	AC power supply input	AC 110~230V	
	AC	AC power supply input		
	PE	Earth Wire		
Motor connection port	U	Motor UVW three-phase		
	V			
	W			
	NC	No connection		
Pulse connection	1	PUL+	Pulse input interface	3.3 ~ 24V level compatible
	2	PUL-		
	3	DIR+	Direction input interface	
	4	DIR-		
Enable connection	7	ENA+	Enable control interface	
	8	ENA-		

Input signal	5	IN1+	Universal input 1	3.3 ~ 24V level compatible
	6	IN1-		
	13	IN2+	Universal input 2	
	14	IN2-		
Output signal	9	ALM+	Alarm Output	24V, below 40mA
	10	ALM-		
	11	RDY+	Ready output	
	12	RDY-		
	15	NC	No definition	

3.2 Power supply input

The driver's working power is AC power, and the input voltage range is between 110V ~ 230V. Please pay attention to confirm the local grid voltage, and do not exceed the maximum voltage of the driver.

The specifications of power supply are single-phase AC power. Please install an EMI device in front of the driver terminals to filter out electromagnetic interference from the power grid.

3.3 Motor connection

The 3R130 driver can drive low resistance and low inductance three-phase hybrid stepping motors below 130 frame.

The common 3-phase stepper motor's lead number are 3 and 6.

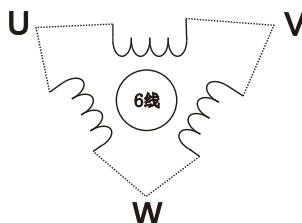
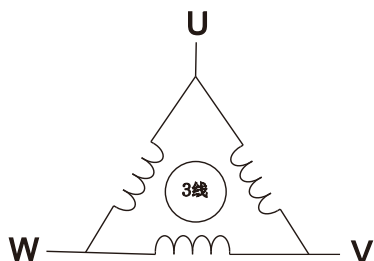

3.4 Control signal connection

3.4.1 PUL, DIR Port: connection for pulse command

The signal interface of standard R series driver is pulse-shaped, and the 3R130 can receive two types of pulse command signals.

The upper controller can be the pulse signal generating device, such as PLC, MCU, control card and controller.

The pulse level that 3R130 driver can be used: 3.3V-24V (no need to connect resistor)

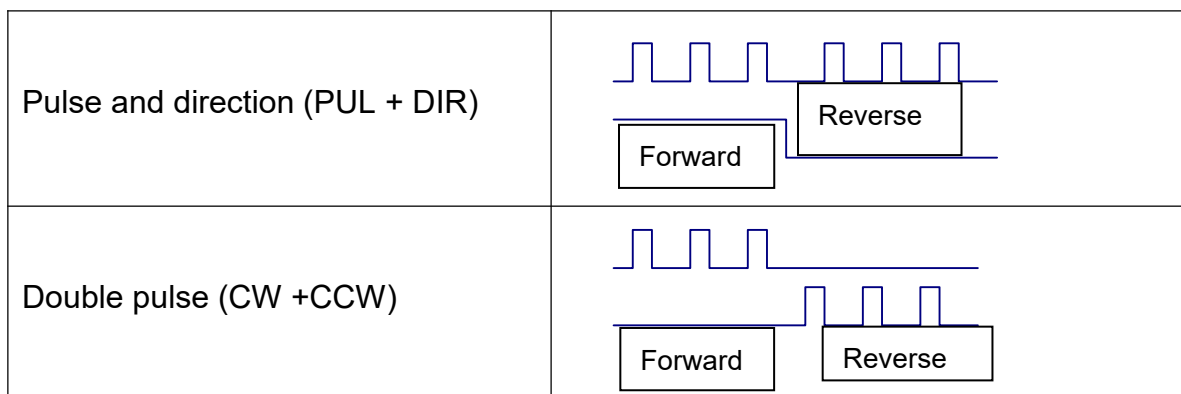

3.4.2 ENA port: enable/disable

By default, when the internal optocoupler is off, the driver outputs current to the motor;

When the internal optocoupler is on, the driver will cut off the current of each phase of the motor to make the motor free, and the step pulse will not be responded.

When the motor is in an error state, it is automatically turned off. The level logic of the enable signal can be set to the opposite.

3.4.3 Input IO signal: IN1, IN2

IN1, IN2 are input signals with optocoupler isolation and can accept differential or single-ended switch value inputs. This signal is the input logic and input pin of the driver, which increases the trigger condition of the driver motion. For specific use, please contact Rtelligent engineer.

3.4.4 Output IO signal: ALM, RDY

ALM and RDY are logic output pins of the driver. By default, they are defined as ALM alarm output and RDY ready signal output. The alarm state and ready state of the driver can be output to the external upper computer system. The output signal can also be defined as other logic outputs. For specific use, please contact Rtelligent engineers.

3.4.5 Examples for pulse enable signal connection

Common Anode

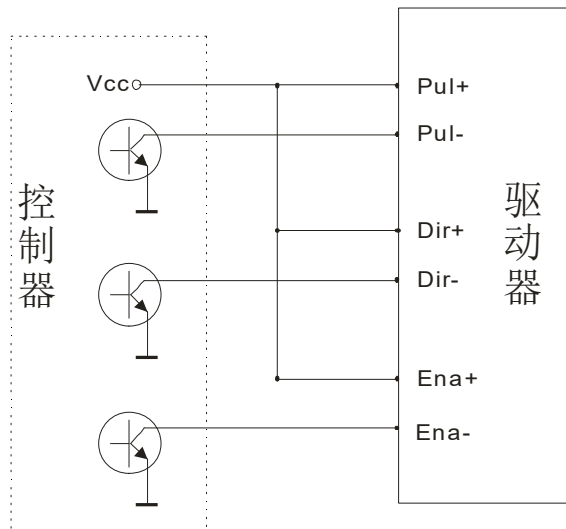

Common Cathode

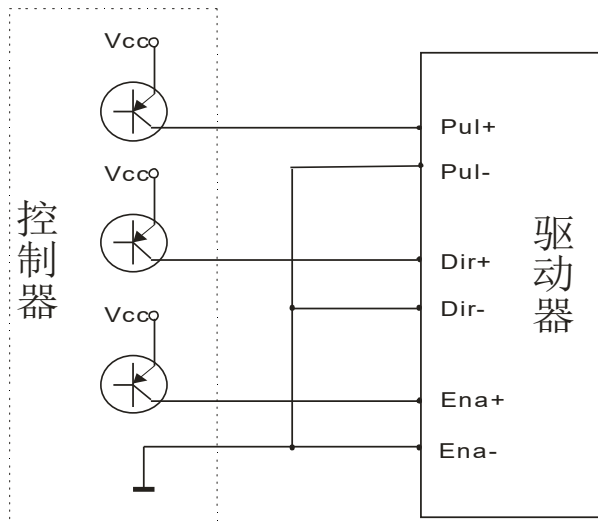

Difference

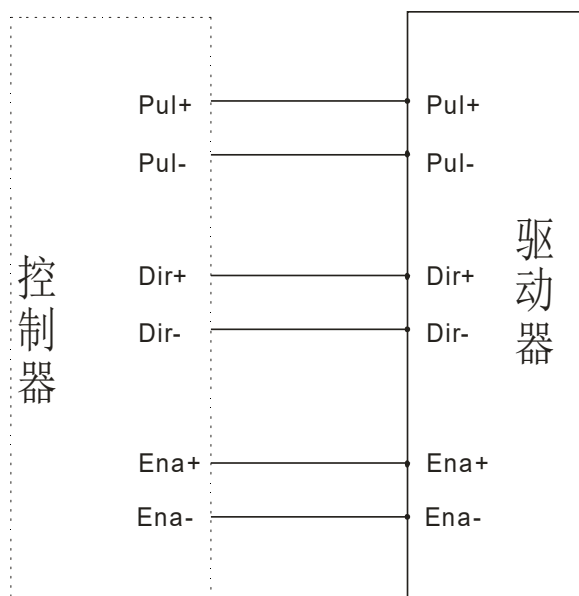

4. The setting of DIP switches and operating parameters

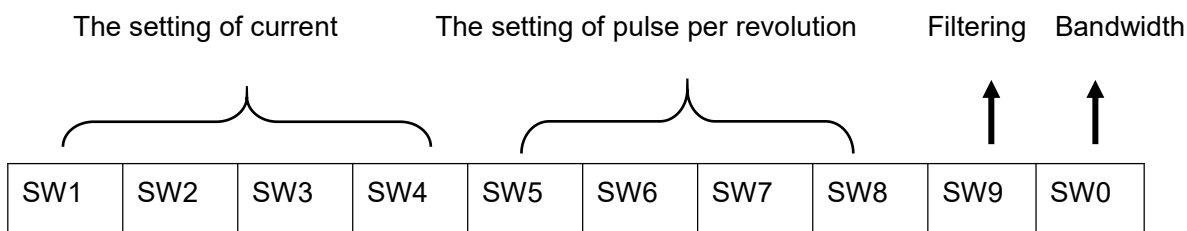

4.1 The setting of current

Average Current	SW1	SW2	SW3	SW4	Remarks
0.7A	on	on	on	on	Other current can be customized.
1.1A	off	on	on	on	
1.6A	on	off	on	on	
2.0A	off	off	on	on	
2.4A	on	on	off	on	
2.8A	off	on	off	on	
3.2A	on	off	off	on	
3.6A	off	off	off	on	
4.0A	on	on	on	off	
4.5A	off	on	on	off	
5.0A	on	off	on	off	
5.4A	off	off	on	off	
5.8A	on	on	off	off	
6.2A	off	on	off	off	
6.6A	on	off	off	off	
7.0A	off	off	off	off	

DIP SW1, SW2, SW3, SW4 are used to set current which is output from driver to motor.

Generally, the current is set to not exceed the rated current of the motor (effective value). If your system has high request to the heating, please decrease the current properly to lower the motor's heating.

4.2 The setting of pulse per revolution

Steps/revolution	SW5	SW6	SW7	SW8	Remarks
400	on	on	on	on	Other pulse per revolution can be customized.
500	off	on	on	on	
600	on	off	on	on	
800	off	off	on	on	
1000	on	on	off	on	
1200	off	on	off	on	
2000	on	off	off	on	
3000	off	off	off	on	
4000	on	on	on	off	
5000	off	on	on	off	
6000	on	off	on	off	
10000	off	off	on	off	
12000	on	on	off	off	
20000	off	on	off	off	
30000	on	off	off	off	
60000	off	off	off	off	

DIP SW5, SW6, SW7, and SW8 are used to set the pulse per revolution required by the motor.

Motor speed = command pulse frequency ÷ pulse per revolution

Motor stroke = number of command pulses ÷ pulse per revolution

4.3 Filter selection

DIP SW9 is used to select the pulse smoothing filter function of the driver.

off means that the driver's internal S-type pulse smoothing function is not applied when the driver receives an external command;

On means that when the driver receives an external command, the internal S-type pulse smoothing function of the driver is added.





4.4 Bandwidth selection

DIP SW0 is used to select the input pulse frequency range of the driver.

off means that the maximum frequency of the external pulse received by the driver is 200KHz.

On means that the maximum frequency of the external pulse received by the driver is 1MHz.

5. Driver working status LED indication

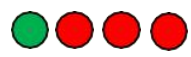
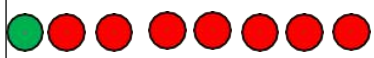
LED Status		Driver Status
	Green indicator is on for long time	Driver not enabled
	Green indicator is flickering	Driver working normally
	One green indicator and one red indicator	Driver overcurrent
	One green indicator and two red indicators	Driver input power overvoltage
	One green indicator and three red indicators	The internal voltage of the driver is wrong
	One green indicator and seven red indicators	Motor phase loss

6. Common faults and troubleshooting

Phenomenon	Possible situations	Solutions
Motor does not work	Power indicator is off	Check the power supply circuit for normal power supply
	The motor rotor is locked but the motor does not work	Pulse signal is weak; increase the signal current to 7-16mA
	The speed is too slow	Select the right micro-stepping
	Driver is protected	Solve the alarm and re-power
	Enable signal problem	Pull up or disconnect the enable signal

	Command pulse is incorrect	Check whether the upper computer has pulse output
The steering of motor is wrong	The rotary direction of motor is reverse	Adjust the DIP SW5
	The motor cable is disconnected	Check the connection
	The motor has only one direction	Pulse mode error or DIR port damaged
Alarm indicator is on	The motor connection is wrong	Check the motor connection
	The motor connection and encoder connection are wrong	Check the sequence of encoder connection
	The voltage is too high or too low	Check the power supply
The position or speed is wrong	The signal is disturbed	Eliminate interference for reliable grounding
	The command input is incorrect	Check the upper computer instructions to ensure the output is correct
	The setting of Pulse per revolution is wrong	Check the DIP switch status and correctly connect the switches
	Encoder signal is abnormal	Replace the motor and contact the manufacturer
The driver terminal burned up	Short circuit between terminals	Check power polarity or external short circuit
	Internal resistance between terminals is too large	Check whether there is any solder ball due to excessive addition of solder on the wire connections
The motor is out of tolerance	Acceleration and deceleration time is too short	Reduce command acceleration or increase Driver filtering parameters
	Motor torque is too low	Select the motor with high torque
	The load is too heavy	Check the load weight and quality and adjust the mechanical structure
	The current of power supply is too low	Replace the appropriate power supply

7. Guarantee clause

7.1 Warranty period: 12 months

We provide quality assurance for one year from the date of delivery and free maintenance service for our products during the warranty period.

7.2 Exclude the following:

- Improper connection, such as the polarity of the power supply is reversed and insert/pull the motor connection when the power supply is connected.
- Beyond electrical and environmental requirements.
- Change the internal device without permission.

7.3 Maintenance process

For maintenance of products, please follow the procedures shown below:

- (1) Contact our customer service staff to get the rework permission.
- (2) The written document of the driver failure phenomenon is attached to the goods, as well as the contact information and mailing methods of the sender.

Mailing address:

Post code:

Tel.: