

# DRV Series Low Voltage Servo Driver

## User Manual



---

## Foreword

First of all, thank you for purchasing the DRV series servo driver!

DRV series servo drive products are small and medium power low voltage servo driver developed by Shenzhen Rtelligent Mechanical Electrical Technology Co., Ltd. The power range of this series of products is 50W ~ 2000W, support a variety of communication protocols: MODBUS communication protocol, CAN communication protocol, EtherCAT communication protocol. The motor with communication type absolute encoder can run quietly and smoothly, and the positioning control is more accurate. It is suitable for printed circuit board punching machines, handling machines, food processing machines, machine tools, transfer machines and other automation equipment to achieve fast and accurate position control, speed control and torque control.

This manual is a comprehensive user manual for DRV series servo drives, providing product safety information, mechanical and electrical installation instructions, commissioning application and maintenance instructions. For first time users, please read this manual carefully. If you have doubts about some functions and performance, please consult our technical support staff for assistance.

Due to the continuous improvement of servo drivers, the information provided by our company is subject to change without notice.

---

## Manual Version Change Record

| Date    | Changed version | Change content         |
|---------|-----------------|------------------------|
| 2021.08 | V1.0            | First edition released |
|         |                 |                        |
|         |                 |                        |
|         |                 |                        |

---

# Contents

|  |           |
|--|-----------|
| <b>FOREWORD</b> .....  | <b>I</b>  |
| <b>MANUAL VERSION CHANGE RECORD</b> .....                        | <b>II</b> |
| <b>CHAPTER 1 SAFETY REMINDER</b> .....                           | <b>1</b>  |
| 1.1 SAFETY PRECAUTIONS.....                                      | 1         |
| 1.2 PRECAUTIONS FOR CONFIRMING THE ARRIVAL OF PRODUCTS.....      | 2         |
| <b>CHAPTER 2 PRODUCT INFORMATION AND INSTALLATION</b> .....      | <b>3</b>  |
| 2.1 DRIVER INTRODUCTION.....                                     | 3         |
| 2.1.1 <i>Nameplate and model description</i> .....               | 3         |
| 2.1.2 <i>Servo driver specifications</i> .....                   | 3         |
| 2.2 DRIVER INSTALLATION INSTRUCTIONS.....                        | 3         |
| 2.2.1 <i>Installation dimensions</i> .....                       | 3         |
| 2.2.2 <i>Installation site</i> .....                             | 4         |
| 2.2.3 <i>Installation environment conditions</i> .....           | 5         |
| 2.2.4 <i>Installation precautions</i> .....                      | 5         |
| <b>CHAPTER 3 SERVO DRIVER AND MOTOR WIRING</b> .....             | <b>6</b>  |
| 3.1 SERVO DRIVER MAIN CIRCUIT CONNECTION.....                    | 6         |
| 3.2 SERVO DRIVER ENCODER SIGNAL TERMINAL X4 CONNECTION.....      | 6         |
| 3.3 SERVO DRIVER CONTROL SIGNAL TERMINAL X3 CONNECTION.....      | 7         |
| 3.3.1 <i>Position command input signal</i> .....                 | 7         |
| 3.3.2 <i>Digital input signal</i> .....                          | 9         |
| 3.3.3 <i>Digital output signal</i> .....                         | 10        |
| 3.3.4 <i>Brake output signal</i> .....                           | 11        |
| 3.4 SERVO DRIVER COMMUNICATION SIGNAL TERMINAL X1.....           | 11        |
| 3.5 USB SERIAL COMMUNICATION TERMINAL X2.....                    | 12        |
| 3.6 ANTI-INTERFERENCE COUNTERMEASURES FOR ELECTRICAL WIRING..... | 12        |
| <b>CHAPTER 4 OPERATION</b> .....                                 | <b>14</b> |
| 4.1 POSITION CONTROL MODE.....                                   | 14        |
| 4.1.1 <i>Position command input setting</i> .....                | 14        |
| 4.1.2 <i>Electronic gear ratio</i> .....                         | 25        |
| 4.1.3 <i>Position command filtering</i> .....                    | 27        |
| 4.1.4 <i>Positioning complete signal</i> .....                   | 27        |
| 4.1.5 <i>Homing function</i> .....                               | 27        |
| 4.2 SPEED CONTROL MODE.....                                      | 33        |
| 1.1.1 <i>Speed command input setting</i> .....                   | 33        |
| 4.3 TORQUE CONTROL MODE.....                                     | 42        |

---

|   |            |
|---|------------|
| 4.3.1 Torque command input setting.....                     | 42         |
| 1.1.2 Speed limit in torque mode.....                       | 46         |
| 1.1.3 Torque arrival output.....                            | 46         |
| 4.4 HYBRID CONTROL MODE.....                                | 48         |
| <b>CHAPTER 5 PARAMETER DESCRIPTION.....</b>                 | <b>49</b>  |
| 5.1 GROUP P00: SERVO DRIVER/MOTOR PARAMETERS.....           | 50         |
| 5.2 GROUP P01: BASIC CONTROL PARAMETERS.....                | 56         |
| 5.3 GROUP P02: TERMINAL INPUT/OUTPUT PARAMETERS.....        | 60         |
| 5.4 GROUP P03: POSITION CONTROL PARAMETERS.....             | 67         |
| 5.5 GROUP P04: SPEED CONTROL PARAMETERS.....                | 75         |
| <b>CHAPTER 6 CHAPTER 6 COMMUNICATION.....</b>               | <b>123</b> |
| 1.2 MODBUS COMMUNICATION.....                               | 123        |
| 1.2.1 Hardware wiring.....                                  | 123        |
| 1.2.2 Communication parameter setting.....                  | 123        |
| 1.3 MODBUS COMMUNICATION PROTOCOL.....                      | 125        |
| 1.3.1 Read register data: 0x03.....                         | 126        |
| 1.3.2 Write a single register: 0x06.....                    | 127        |
| 1.3.3 Writing multiple registers: 0x10.....                 | 128        |
| 1.3.4 Error response frame format.....                      | 129        |
| 1.3.5 CRC check.....  | 130        |
| 1.4 USE OF SERVO DRIVER DEBUGGING SOFTWARE.....             | 131        |
| <b>CHAPTER 7 CHAPTER 7 TROUBLESHOOTING.....</b>             | <b>132</b> |
| 7.1 FAULT LIST.....   | 132        |
| 7.2 FAULT CODES.....  | 132        |
| 7.3 RELATIONSHIP BETWEEN LED INDICATION AND FAULT CODE..... | 136        |
| <b>CHAPTER 8 CHAPTER 8 APPENDIX.....</b>                    | <b>138</b> |
| APPENDIX B LIST OF SERVO PARAMETERS.....                    | 138        |
| Group P00 Servo Driver/motor parameters.....                | 138        |
| Group P01 Basic control parameters.....                     | 139        |
| Group P02 Terminal input/output parameters.....             | 140        |
| Group P03 Position control parameters.....                  | 141        |
| Group P04 Speed control parameters.....                     | 142        |
| Group P05 Torque control parameters.....                    | 143        |
| Group P06 Gain parameters.....                              | 144        |
| Group P08 Communication parameters.....                     | 145        |
| Group P09 Multi-segment position parameters.....            | 146        |

---

|   |     |
|---|-----|
| <i>Group P10 Multi-segment speed parameters</i> ..... | 148 |
| <i>Group P11 Auxiliary display</i> .....              | 150 |
| <i>Group P12 Auxiliary functions</i> .....            | 152 |
| <i>Group P13 Monitoring parameters</i> .....          | 153 |

# Chapter 1 Safety Reminder

## 1.1 Safety precautions

- ◆ Cut off the power supply for more than 5 minutes before disassembling and installing the driver. Otherwise, it may cause electric shock due to residual voltage.
- ◆ Please never touch the inside of the servo driver, otherwise it may cause electric shock.
- ◆ Please insulate the connection part of the power terminal, otherwise it may cause electric shock.
- ◆ The grounding terminal of the servo driver must be grounded, otherwise it may cause electric shock.
- ◆ Do not damage or pull the cable forcefully, and do not subject the cable to excessive force, place it under heavy objects, or clamp it. Otherwise, it may cause electric shock, cause the product to stop operating or burn out.
- ◆ Do not set up, disassemble and repair unless designated personnel, otherwise it may cause electric shock or injury.
- ◆ Do not remove the cover, cables, connectors and optional accessories when the power is on, otherwise it may cause electric shock and damage the driver.
- ◆ Please follow the steps required by this manual for trial operation.
- ◆ When the servo motor is connected to the machine, if an operation error occurs, it will not only cause damage to the machine, but also sometimes cause personal accidents.
- ◆ Do not change the maximum speed value except for special purposes. If you change it accidentally, it may damage the machine or cause injury.
- ◆ When the power is turned on and for a period of time after the power is cut off, the heat sink of the servo driver, the external braking resistor, the servo motor, etc. may become hot. Please do not touch it, otherwise it may cause burns. In order to prevent your hands or components (such as cables, etc.) from contacting them negligently, please take safety measures such as installing the enclosure.
- ◆ When the servo motor is running, please never touch its rotating part, otherwise you may get injured.
- ◆ When installing on the supporting machinery and starting to run, please put the servo motor in a state where it can be stopped at any time in advance, otherwise it may be injured.
- ◆ Please install a stop device on the machine side to ensure safety.
- ◆ The brake of the servo motor with brake is not a stopping device to ensure safety. If the stop device is not installed, it may cause injury.
- ◆ If the power supply is restored after a momentary power failure occurs during operation, the machine may restart suddenly, so please do not approach the machine.
- ◆ Please take measures to ensure that personal safety will not be endangered when restarting, otherwise it may cause injury.
- ◆ Please never modify this product, otherwise it may cause injury or mechanical damage.

- ◆ Please install the servo driver, servo motor, and external braking resistor on non-combustible materials, otherwise it may cause a fire.
- ◆ Be sure to connect an electromagnetic contactor and a non-fuse circuit breaker between the power supply and the main circuit power supply of the servo driver. Otherwise, when the servo driver fails, the large current cannot be cut off, which may cause a fire.
- ◆ Please do not mix oil, grease and other flammable foreign objects and screws, metal pieces and other conductive foreign objects inside the servo driver and the servo motor.

## 1.2 Precautions for confirming the arrival of products

| Confirmation Items   | Description  |
|--|--|
| Does the delivered product match the model of the product you ordered? | The packing box contains the machine you ordered. Please confirm it on the nameplate model of the servo motor and servo driver.  |
| Is there any damage to the product?                                    | Please check the positive surface to see if the product is damaged during transportation. If any omission or damage is found, please contact our company or your supplier as soon as possible. |
| Is the servo motor rotating smoothly?                                  | It is normal to be able to turn gently by hand. Except for servo motors with brakes.   |



## Chapter 2 Product Information and Installation

### 2.1 Driver Introduction

#### 2.1.1 Nameplate and model description

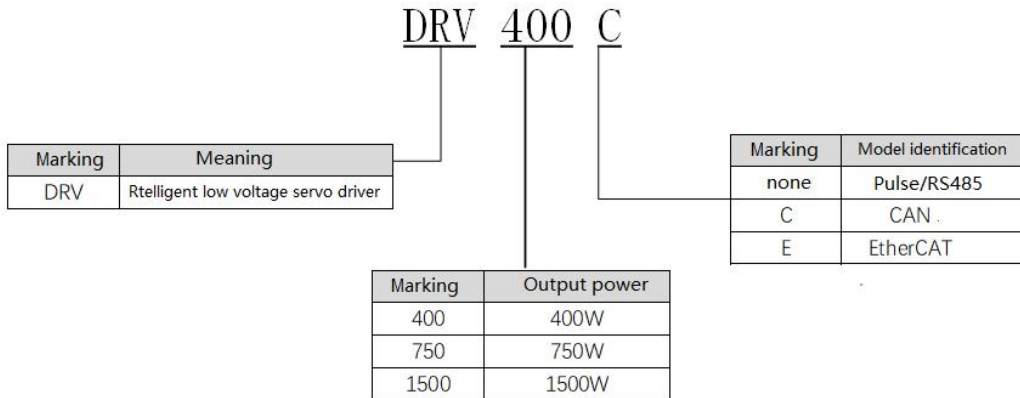

#### 2.1.2 Servo driver specifications

| Item                           | Description               |        |         |
|--------------------------------|---------------------------|--------|---------|
| Driver model                   | DRV400                    | DRV750 | DRV1500 |
| Continuous output current Arms | 12                        | 25     | 38      |
| Maximum output current Arms    | 36                        | 70     | 105     |
| Main circuit power supply      | DC 24-70V                 |        |         |
| Brake processing function      | Braking resistor external |        |         |

### 2.2 Driver installation instructions

#### 2.2.1 Installation dimensions

Dimensions of DRV400/DRV400C/DRV400E、DRV750/DRV750C/DRV750E:

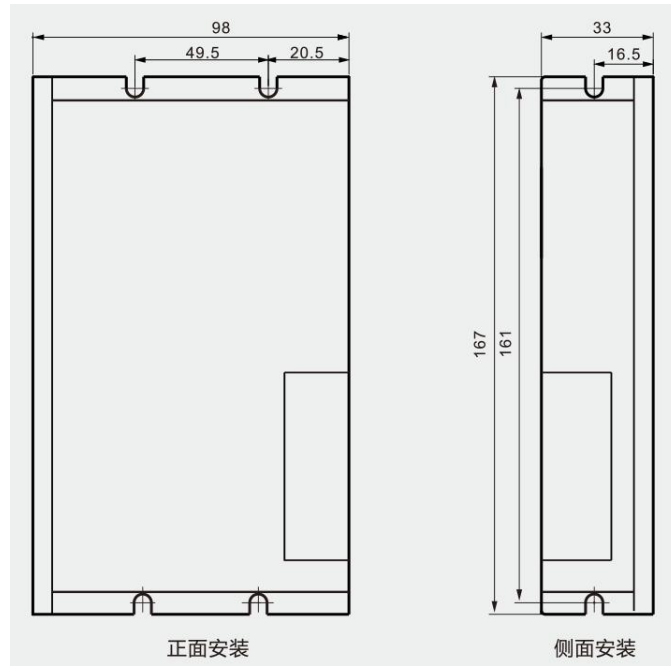

Dimensions of DRV1500/DRV1500C/DRV1500E:

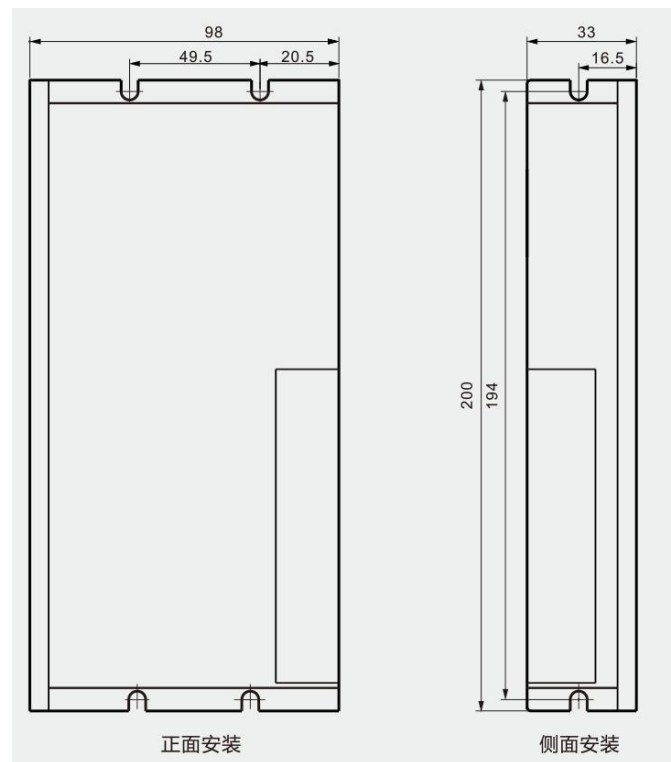

## 2.2.2 Installation site

- Please install in a mounting cabinet free from sun and rain.
- Do not use this product in the vicinity of corrosive and flammable gas environments such as hydrogen sulfide, chlorine, ammonia, sulfur, chlorinated gases, acids, alkalis, salts, combustible materials, etc.
- Do not install in high temperature, humid, dusty, metal dusty environment.

- Vibration-free places.
- Pollution level of the installation site: PD2.

## 2.2.3 Installation environment conditions

The installation environment of the servo driver has a direct impact on the normal function of the drive and its service life. Therefore, the installation environment of the driver must meet the following conditions:

| Item                          | Description   |
|-------------------------------|---|
| Operating ambient temperature | 0~55°C (ambient temperature is above 45°C, average load rate should not exceed 80%) (no freezing) |
| Operating ambient humidity    | Below 90%RH (no condensation)   |
| Storage temperature           | -20~85°C (not freezing)   |
| Storage Humidity              | Below 90%RH(no condensation)  |
| Vibration                     | Below 4.9m/s <sup>2</sup>   |
| Shock                         | Below 19.6 m/s <sup>2</sup>   |
| Protection level              | IP10  |
| Altitude                      | Below 1000m   |

## 2.2.4 Installation precautions

- Please ensure that the installation direction is perpendicular to the wall, and use natural air convection or a fan to cool the servo driver. Through 2 mounting holes (the number of mounting holes varies according to the capacity), the servo drive is firmly fixed on the mounting surface. When installing, please face the front of the driver to the operator and make it perpendicular to the wall. Please pay attention to avoid drilling iron filings and other foreign matter from falling into the driver during installation, otherwise it may cause the driver to malfunction.
- In order to ensure good heat dissipation conditions, the actual installation should be as large as possible.
- When multiple drives are installed in the control cabinet, please note that sufficient space must be reserved for the placement position to achieve sufficient heat dissipation.
- Be sure to connect the ground terminal to the ground, otherwise there may be a risk of electric shock or interference resulting in malfunction.
- When there is a vibration source (punch) near the driver installation, if it is unavoidable, please use a vibration absorber or install an anti-vibration rubber gasket.
- When there are large magnetic switches, fusion splicers and other noise sources near the driver, it is easy for the driver to be interfered with by the outside world and cause malfunction, so it is necessary to install noise filters, but noise filters will increase the leakage current, so it is necessary to install an insulating transformer at the input of the driver.

## Chapter 3 Servo Driver and Motor Wiring

### 3.1 Servo driver main circuit connection

| Terminal mark | Terminal name                   | Terminal function  |
|---------------|---------------------------------|--|
| DC+, DC-      | Power supply input terminal     | Servo driver power supply input terminal, the voltage is within the range of DC 18-70V               |
| DC+, RB-      | Braking resistor terminal       | Connect energy consumption braking resistor  |
| U、V、W、PE      | Servo motor connection terminal | Servo motor connection terminal, must be connected with the motor U, V, W, PE terminal corresponding |

Precautions for circuit wiring:

- Do not connect the input power cable to the output U, V, W, otherwise it will cause damage to the servo driver.
- Do not pass or bundle power and signal cables together from the same pipe. To avoid interference, the distance between the two should be more than 30cm.
- Do not ON/OFF the power supply frequently. When it is necessary to ON/OFF the power supply repeatedly and continuously, please control it less than once a minute. Since the power supply part of the servo driver has a capacitor, a large charging current (charging time 0.2s) will flow when the power supply is turned on. If the power is turned on/off frequently, the performance of the main circuit components inside the servo driver will be degraded.
- Please connect the servo driver to the ground reliably, and use a PE wire with a large diameter as much as possible to ensure that the grounding resistance is less than 100 ohms.
- It is recommended that the power supply be supplied through a noise filter to improve the anti-interference ability.
- Please install a non-fuse type (NFB) circuit breaker so that the external power supply can be cut off in time when the driver fails.
- Do not power on and use the servo driver when the terminal screws or cables are loose, otherwise it may cause a fire.

### 3.2 Servo driver encoder signal terminal X4 connection

Servo motor encoder output terminal signal definition: face up to the motor encoder output terminal, its terminal definition serial number is shown in the following diagram:

| Schematic diagram of servo motor encoder outlet terminal |            |                              |  |
|--|------------|------------------------------|--|
| Signal name  | Pin number | Function                     |  |
| FG   | 1          | Shield ground                |  |
| +5V  | 2          | Power input positive:<br>+5V |  |

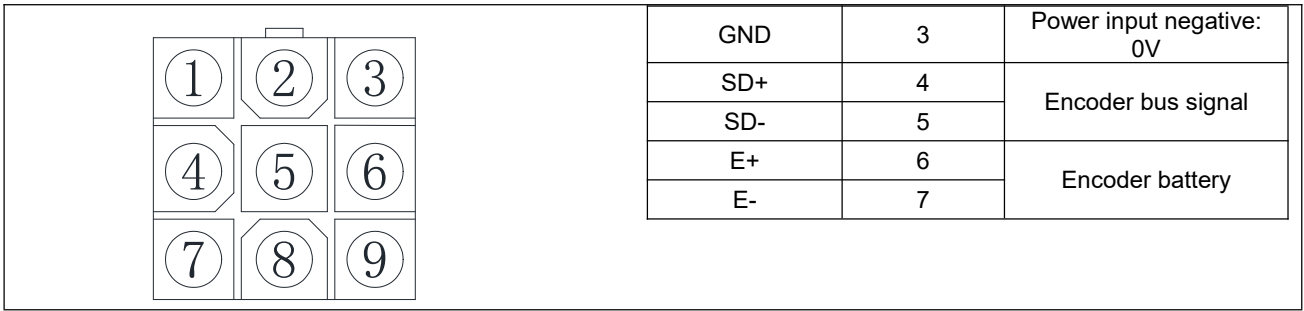

Servo encoder extension cable motor-side terminal: face up to the servo encoder extension cable motor-side terminal, the definition number of its terminal is shown in the following diagram:

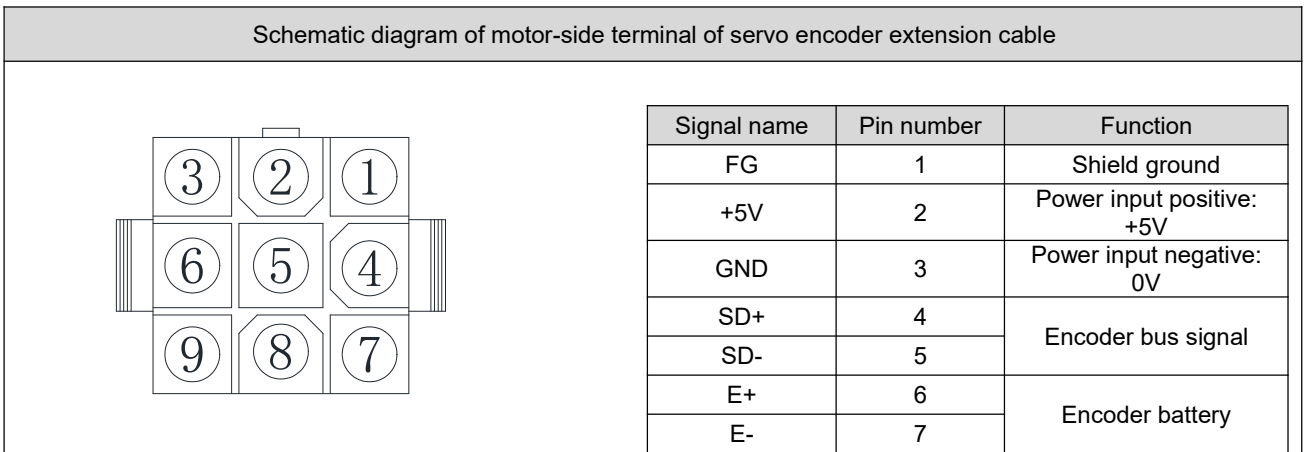

Servo encoder extension cable driver-side terminal: The servo encoder extension cable driver-side terminal is a soldered pin, and the pin number is marked on it. The definition number of the terminal is shown in the following diagram:

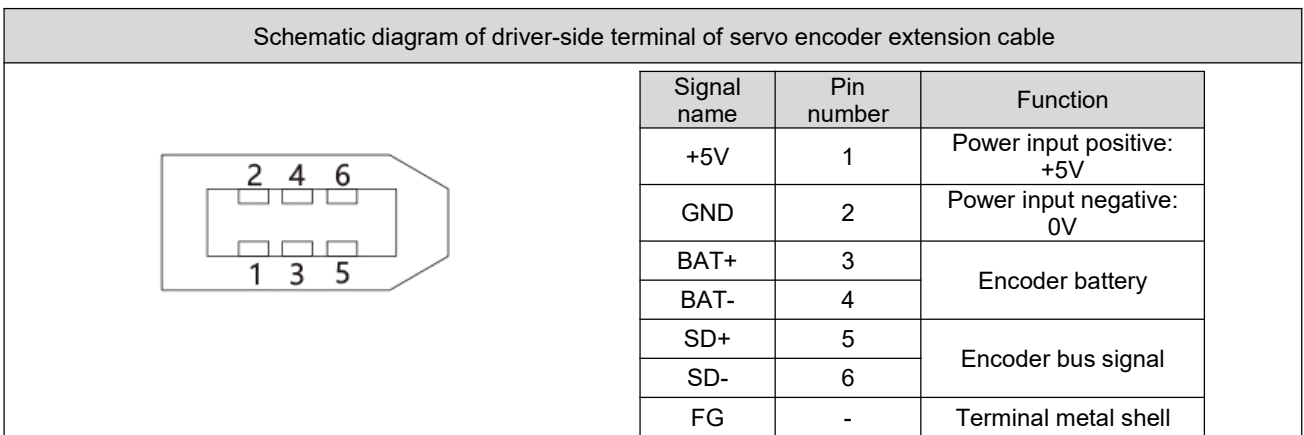

### 3.3 Servo driver control signal terminal X3 connection

#### 3.3.1 Position command input signal

Note: The pulse input signal can only be connected to the DRV pulse model/RS485 model driver:

| Signal name | Pin number | Function |
|-------------|------------|----------|
|-------------|------------|----------|

|                  |      |   |  |
|------------------|------|---|--|
| Position command | PUL+ | 1 | External command pulse input terminal, the input pulse forms are:<br>● Pulse + direction<br>● CW/CCW pulse<br><b>Note: The signal terminal can accept 5V-24V signals, no need to connect resistors in series</b> |
|                  | PUL- | 3 |  |
|                  | DIR+ | 5 |  |
|                  | DIR- | 7 |  |

(1) Differential pulse signal

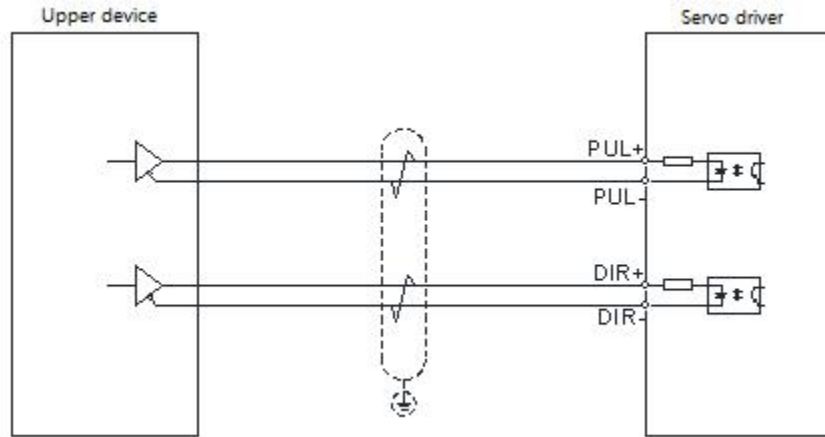

(2) Single-ended common anode signal

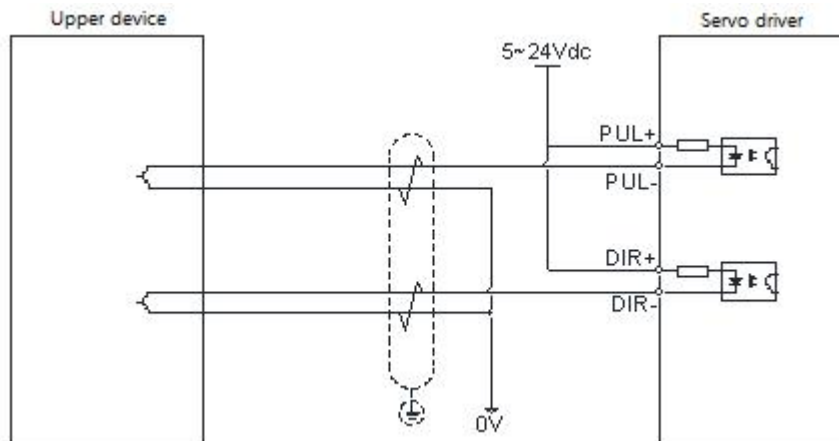

(3) Single-ended common cathode signal

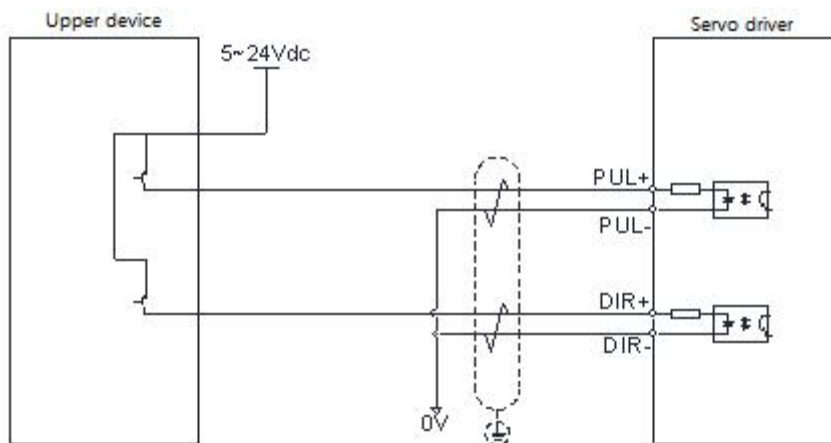

### 3.3.2 Digital input signal

DRV series pulse/RS485 driver:

| Signal name              | Default function | Pin number | Function              |
|--------------------------|------------------|------------|-----------------------|
| General input and output | COM24V+          | 2          | Input terminal common |
|                          | IN1              | 4          | Servo enable          |
|                          | IN2              | 6          | Positive limit        |
|                          | IN3              | 8          | Negative limit        |
|                          | IN4              | 10         | Origin                |

DRV series EtherCAT、CAN driver:

| Signal name              | Default function | Pin number | Function              |         |
|--------------------------|------------------|------------|-----------------------|---------|
| General input and output | COM24V+          | 2          | Input terminal common |         |
|                          | IN1              | 4          | Positive limit        |         |
|                          | IN2              | 6          | Negative limit        |         |
|                          | IN3              | 8          | Origin                |         |
|                          | IN4              | 10         | Emergency stop        |         |
|                          | IN5+             | P_OT       | 1                     | Probe 1 |
|                          | IN5-             |            | 3                     |         |
|                          | IN6+             | GEAR_SEL   | 5                     | Probe 2 |
|                          | IN6-             |            | 7                     |         |

The IN5 and IN6 interface circuits are the same as PUL and DIR, please refer to the wiring instructions of the position command input signal. The interface circuits of IN1~IN4 are the same. Take IN1 as an example.

1) When the upper computer device is a relay output:

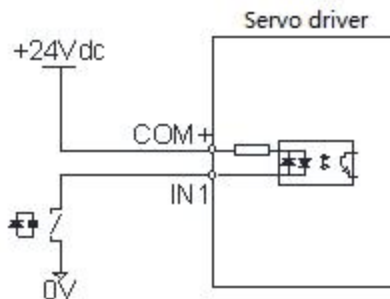

2) When the upper computer device is open-collector output:

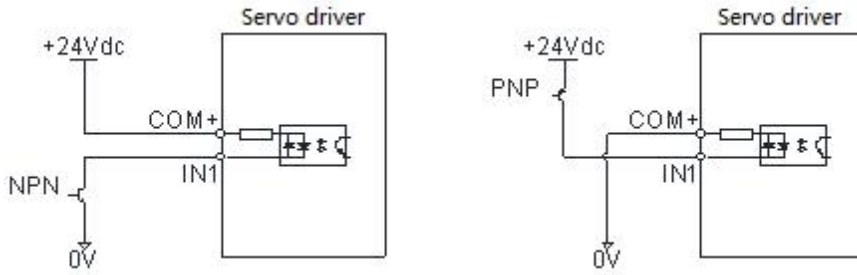

### 3.3.3 Digital output signal

| Signal name              |       | Default function | Pin number | Function         |
|--------------------------|-------|------------------|------------|------------------|
| General input and output | OUT1+ | ALM              | 9          | Alarm output     |
|                          | OUT1- |                  | 11         |                  |
|                          | OUT2+ | HOME_DONE        | 13         | Homing completed |
|                          | OUT2- |                  | 15         |                  |

The OUT1 and OUT2 interface circuits are the same. Take OUT1 as an example.

1) When the upper device is a relay input::

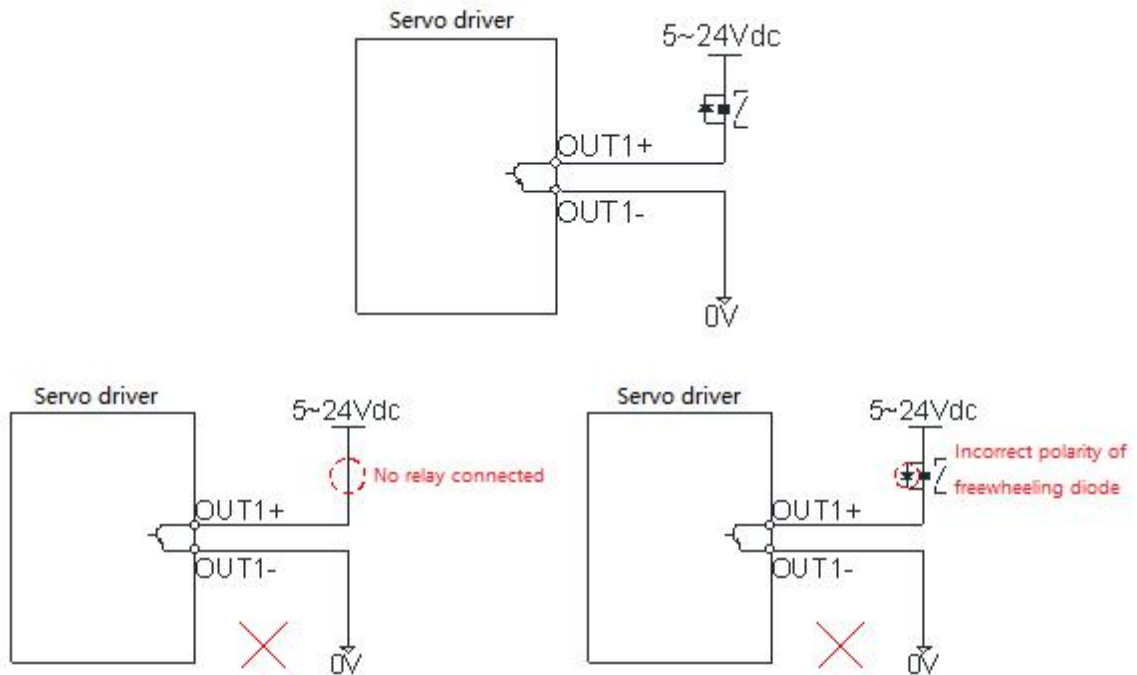

2) When the upper device is optocoupler input:



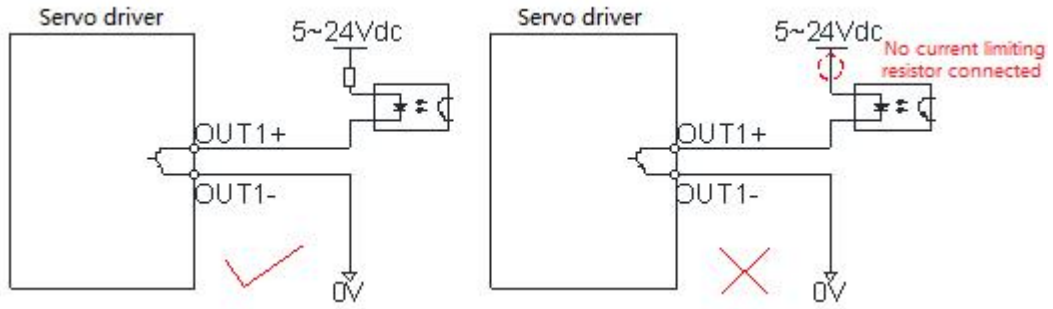

### 3.3.4 Brake output signal

| Signal name              |      | Default function | Pin number | Function   |
|--------------------------|------|------------------|------------|--|
| General input and output | BRK+ | BRK              | 14         | Brake output terminal<br>It can be directly connected to the positive and negative signal terminals of the electromagnetic brake of the motor, without driving through a relay |
|                          | BRK- |                  | 16         |  |

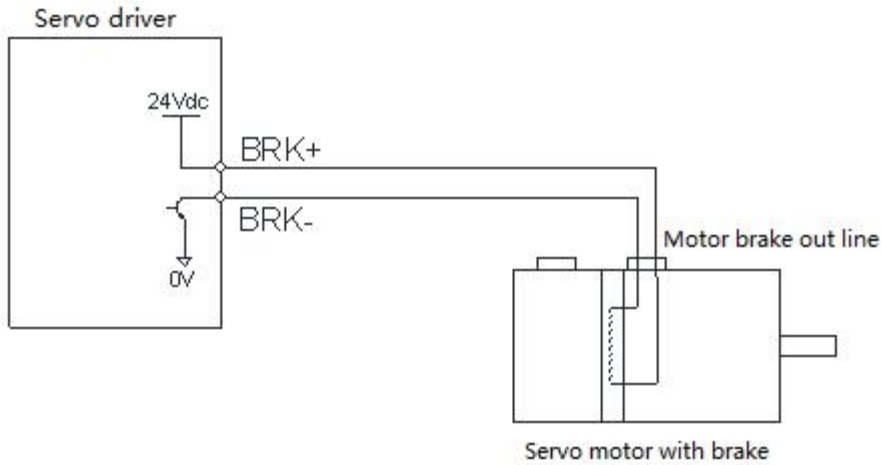

### 3.4 Servo driver communication signal terminal X1

DRV series pulse/RS485 driver、DRV series CAN driver:

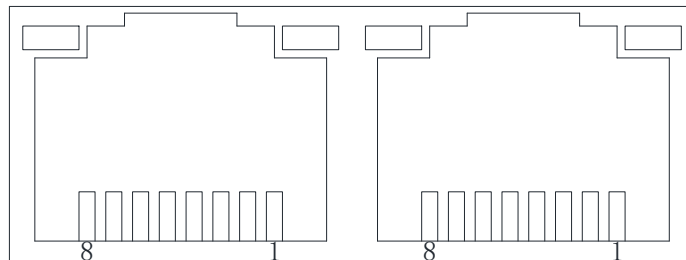

| Signal name   |        | Default function | Pin number               |
|---------------|--------|------------------|--------------------------|
| Communication | RS485+ | 1                | RS485 communication port |

|        |        |   |                        |            |
|--------|--------|---|------------------------|------------|
| signal | RS485- | 2 | CAN communication port |            |
|        | -      | 3 |                        |            |
|        | CAN_H  | 4 |                        |            |
|        | CAN_L  | 5 |                        |            |
|        | -      | 6 |                        |            |
|        | DGND   | 7 |                        | GND signal |
|        | -      | 8 |                        | -          |

**DRV series EtherCAT driver:**

The EtherCAT network cable is connected to the RJ45 terminal with a metal shield, and has input (IN) and output (OUT) interfaces. The electrical characteristics comply with IEEE802.3 and ISO8877 standards.

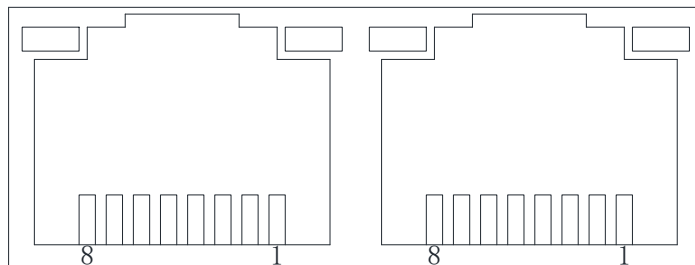

| Pin | Definition | Description   |
|-----|------------|---------------|
| 1   | TX+        | Data send+    |
| 2   | TX-        | Data send-    |
| 3   | RX+        | Data receive+ |
| 4   | NULL       | Null          |
| 5   | NULL       | Null          |
| 6   | RX-        | Data receive- |
| 7   | NULL       | Null          |
| 8   | NULL       | Null          |

**3.5 USB serial communication terminal X2**

Customers can modify the parameters of the driver on the PC using the Mini USB communication cable.

**3.6 Anti-interference countermeasures for electrical wiring**

To suppress interference, please take the following measures:

- ◆ The length of the command input cable should be less than 3m, and the encoder cable should be less than 20m.

- ◆ Use thick wires as much as possible for grounding wiring. (Above 2.0mm<sup>2</sup>)
- ◆ Please use a noise filter to place radio frequency interference. When using in a civil environment where the power supply interference noise is strong, please install a noise filter on the input side of the power cord.
- ◆ In order to place the malfunction caused by electromagnetic interference, the following treatment methods can be adopted:
  - ① Install the upper computer device and the noise filter near the servo driver as far as possible.
  - ② Install surge suppressors on the coils of relays, screw tubes, and electromagnetic contactors.
  - ③ When wiring, please lay the strong current line separately from the weak current line, and keep an interval of more than 30cm. Do not put them in the same pipe or bundle them together.
  - ④ Do not share power supply with electric welders, electrical discharge machining equipment, etc. When there is a high-frequency generator nearby, install a noise filter on the input side of the power cord.

## Chapter 4 Operation

### 4.1 Position control mode

The position control mode is mainly used in occasions that require positioning control, such as manipulators, placement machines, engraving (pulse sequence instructions), CNC machine tools, etc. Set the value of parameter P01.00 to 0 to enable the drive to work in position control mode.

#### 4.1.1 Position command input setting

In position control mode, first set the position command source through P03.00.

★ Description of related parameters

| Parm   | Name                    | Setting range  | Function  | Setting method     | Effective time        | Factory setting |
|--------|-------------------------|--|---|--------------------|-----------------------|-----------------|
| P03.00 | Position command source | 0: Pulse command<br>1: Stepper operation<br>2: Multi-segment position command<br>3: Communication control<br>4: Communication control 2<br>5: IO control | Set the source of the position command. The pulse command is an external position command, and the others are internal position commands. | Set after stopping | Effective immediately | 0               |

#### a) The source of position command is pulse command (P03.00=0)

When setting the position command source as pulse command, it is necessary to correctly set the command type of external pulse according to the host computer or other pulse output device:

- Direction + pulse (positive logic or negative logic)
- A phase + B phase quadrature pulse, 4 times frequency
- Positive pulse / negative pulse (CW + CCW)

★ Description of related parameters

| Parm   | Name               | Setting range   | Function                                  | Setting method     | Effective time   | Factory setting |
|--------|--------------------|---|---|--------------------|------------------|-----------------|
| P03.01 | Pulse command type | 0: direction + pulse (positive logic)<br>1: Direction + pulse (negative logic)<br>2: CW + CCW<br>3: A phase + B phase quadrature pulse, 4 times the frequency | Select the type of external pulse command | Set after stopping | Save and restart | 0               |

Table 4-2 Description of pulse command types

| P01.01<br>Rotation direction<br>selection | P03.02<br>Command<br>type setting | Command type   | Signal                       | Schematic diagram of<br>forward pulse | Schematic diagram of<br>reverse pulse |
|---|-----------------------------------|--|------------------------------|---------------------------------------|---------------------------------------|
| 0   | 0                                 | Pulse + direction<br>Positive logic                        | PUL<br>DIR                   |                                       |                                       |
|   | 1                                 | Pulse + direction<br>Negative logic                        | PUL<br>DIR                   |                                       |                                       |
|   | 2                                 | CW+CCW   | PUL(CW)<br>DIR(CCW)          |                                       |                                       |
|   | 3                                 | A phase + B phase<br>Quadrature pulse<br>4 times frequency | PUL(A phase)<br>DIR(B phase) |                                       |                                       |
| 1   | 0                                 | Pulse + direction<br>Positive logic                        | PUL<br>DIR                   |                                       |                                       |
|   | 1                                 | Pulse + direction<br>Negative logic                        | PUL<br>DIR                   |                                       |                                       |
|   | 2                                 | CW+CCW   | PUL (CW)<br>DIR (CCW)        |                                       |                                       |
|   | 3                                 | A phase + B phase<br>Quadrature pulse<br>4 times frequency | PUL(A phase)<br>DIR(B phase) |                                       |                                       |

**b) The position command source is the step amount (P03.00=1)**

In this position command source:

- The fixed-length operation of the motor is controlled through the external input terminal, and the direction of operation is determined by the sign of the pulse command stroke.

**(1) Control motor fixed-length forward/reverse rotation through external input terminal**

★ Description of related parameters

| Parm             | Name                  | Setting range                  | Unit        | Function  | Setting method   | Effective time | Factory setting |
|------------------|-----------------------|--------------------------------|-------------|---|------------------|----------------|-----------------|
| P03.28<br>P03.29 | Stepper operation     | -<br>1073741824~<br>1073741824 | Common unit | Set the motor's fixed-length running stroke<br>Positive number means positive direction rotation<br>Negative number means negative direction rotation | Set when running | Next run       | 10000           |
| P03.30           | Stepper running speed | 0~6000                         | r/min       | Set the motor's fixed-length running speed  | Set when running | Next run       | 1000            |
| P03.31           | Stepper               | 1~65535                        | ms          | Set the time for the motor's fixed-   | Set when         | Next run       | 200             |

|        |  |         |    |   |                  |          |     |
|--------|--|---------|----|---|------------------|----------|-----|
|        | operation acceleration time constant         |         |    | length running speed to uniformly accelerate from 0r/min to 1000r/min   | running          |          |     |
| P03.32 | Stepper operation deceleration time constant | 1~65535 | ms | Set the time that the motor's fixed-length running speed is uniformly decelerated from 1000r/min to 0r/min      | Set when running | Next run | 200 |
| P01.33 | Emergency stop deceleration time constant    | 1~65535 | ms | Set the time for the motor to decelerate uniformly from 1000r/min to 0r/min when the motor is in emergency stop | Set when running | Next run | 30  |

The startup mode is as follows:

1、 1. Set the corresponding IN terminal function to 13 (FunIN13: stepper position trigger), and confirm the valid logic of the IN terminal. [Group P02: terminal input/output parameters](#)

★ Description of related parameters

| Code     | Function name            | Function   |
|----------|--------------------------|--|
| FunIN.13 | stepper position trigger | The servo running status is as follows:<br>Valid: the motor runs the position command stroke set by parameter P03.28/P03.29<br>Invalid: the servo motor is in the locked state |

FunIN.13 (stepper position trigger) is valid for edge change, the stepper position command is completed and the servo motor enters the locked state, if FunIN.13 is triggered again, the servo motor will repeat the position command stroke set in P03.28/P03.29.

● Note: The motor will not respond to the re-trigger signal if the motor's current position command is not run to end stop. The user can receive the output signal (FunOUT.5: internal position command stop) through the host computer, which is used to determine whether the internal pulse of the servo driver has been sent to determine the validity of the trigger again.

**c) The source of position command is multi-segment position command (P03.00=2)**

The servo driver has the function of multi-segment position operation. It means that there are 16 position commands stored inside the servo driver, and the displacement, maximum operating speed and acceleration/deceleration time of each segment can be set separately. The waiting time and connection mode between the segments can also be selected according to actual needs. The setting process is as follows:

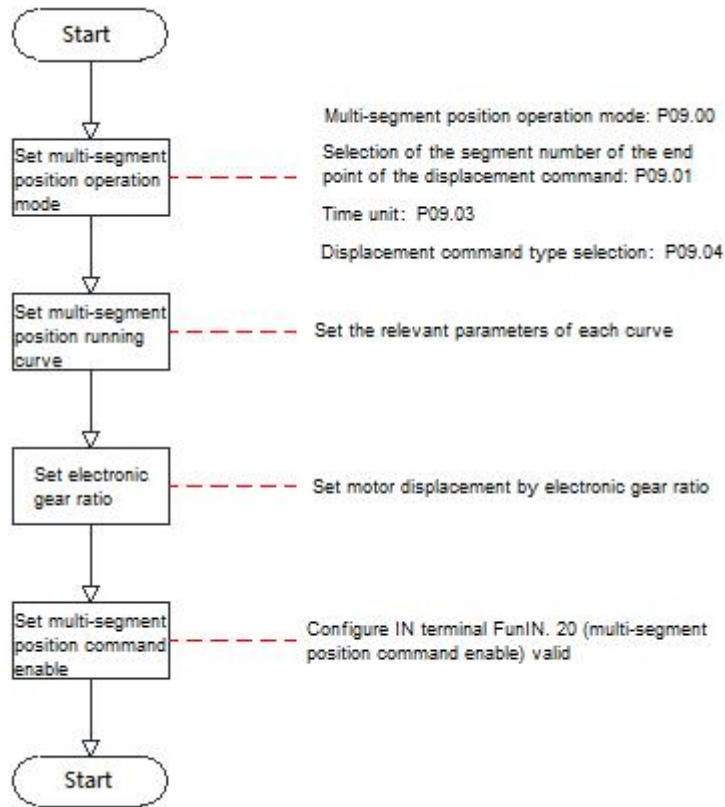

① Set multi-segment position operation mode

★ Description of related parameters

| Parm   | Name                                    | Setting range   | Function   | Setting method     | Effective time | Factory setting |
|--------|---|---|--|--------------------|----------------|-----------------|
| P09.00 | Multi-segment position operation method | 0: Shutdown at the end of a single run<br>1: Cycle operation<br>2: IN switching operation | Set the connection mode between the multi-segment position running section and the section | Set after stopping | Next run       | 1               |
| P09.01 | Number of position command end segments | 1~16  | Set the total number of segments of multi-segment position commands                        | Set after stopping | Next run       | 1               |
| P09.03 | Waiting time unit                       | 0: ms<br>1: s   | Set the waiting time unit.<br>Note: the waiting time is only valid when P09.00=0 or 1      | Set after stopping | Next run       | 0               |
| P09.04 | Displacement command type selection     | 0: Incremental position command<br>1: Absolute position command                           | Set the type of multi-segment displacement command   | Set after stopping | Next run       | 0               |

● Shutdown at the end of a single run (P09.00=0)

| Mode description  | Running curve   |
|---|---|
| <ul style="list-style-type: none"> <li>Run 1 round</li> <li>The segment number is automatically incremented and switched</li> <li>The waiting time can be set between each segment</li> <li>FunIN.21 (multi-segment position command enable) signal is level effective</li> </ul> | <p><math>V_{1max}</math>、<math>V_{2max}</math>: Maximum operating speed of the first and second</p> |

|  |  |
|--|--|
|  | <p>segment</p> <p><math>S_1</math>、<math>S_2</math>: Segment 1 and segment 2 displacement</p> <ul style="list-style-type: none"> <li>● After each segment of operation is completed, the motor's internal command stop signal output is valid;</li> <li>● When the multi-segment position command is enabled OFF during operation, the driver gives up the uncompleted displacement of this segment and stops, and the positioning completion signal is valid after the stop is completed</li> <li>● Re-enable the multi-segment position command, and the driver will start to run sequentially from the first segment again</li> </ul> |
|--|--|

★ Term explanation:

The total number of multi-segment position commands set by P09.01 when the driver completes one run is called the completion of one round of operation.

● Cycle operation (P09.00=1)

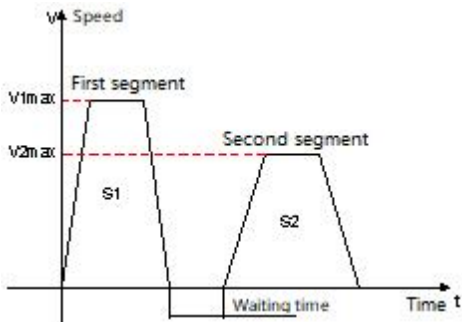
| Mode description   | Running curve  |
|--|--|
| <ul style="list-style-type: none"> <li>● Cycle operation, the starting segment number of each round is 1;</li> <li>● The segment number is automatically incremented and switched;</li> <li>● Waiting time can be set between each segment;</li> <li>● The FunIN.21 (multi-segment position command enable) signal is level valid, and its signal is valid, the driver will keep cyclic operation status.</li> </ul> |  <p><math>V_{1max}</math>、<math>V_{2max}</math>: Maximum operating speed of the first and second segment</p> <p><math>S_1</math>、<math>S_2</math>: The first segment and the second segment displacement</p> <ul style="list-style-type: none"> <li>● After each segment of operation is completed, the motor's internal command stop signal output is valid;</li> <li>● When the multi-segment position command is enabled OFF during operation, the driver gives up the uncompleted displacement of this segment and stops, and the positioning completion signal is valid after the stop is completed</li> <li>● Re-enable the multi-segment position command, and the driver will start to run sequentially from the first segment again</li> </ul> |

● IN switching operation (P09.00=2)

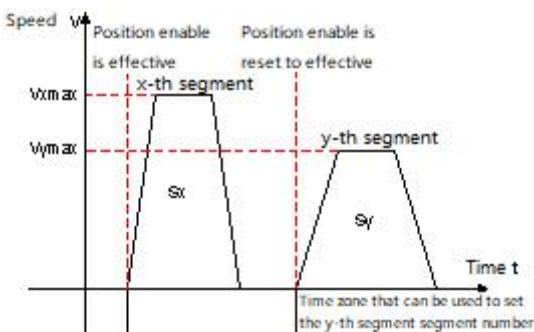
| Mode description  | Running curve  |
|---|--|
| <ul style="list-style-type: none"> <li>● When running the current segment number, the next running segment number can be set, and the motor will stop after completing the position command set by the current segment number. After the multi-segment position command enable is set to ON again, run this time period number command</li> </ul> |  <p>Position enable is effective</p> <p>Position enable is reset to effective</p> <p><math>v_{xmax}</math>、<math>v_{ymax}</math></p> <p><math>S_x</math>、<math>S_y</math></p> <p>Time zone that can be used to set the y-th segment segment number</p> |



|   |   |
|---|---|
| <ul style="list-style-type: none"> <li>● The segment number is determined by the IN terminal logic</li> <li>● There is no waiting time between each segment, the interval time is determined by the command delay of the host computer</li> <li>● FunIN.21 (segment position command enable) signal is valid for edge change</li> </ul> | <p><math>V_{xmax}</math>、<math>V_{ymax}</math>: Maximum operating speed of the x-th and y-th segment<br/> <math>S_x</math>、<math>S_y</math>: The x-th segment and the y-th segment displacement</p> <ul style="list-style-type: none"> <li>● After each stage of operation is completed, the internal command stop signal output of the motor is valid;</li> <li>● During operation, the multi-segment position command enable is OFF, the driver continues to execute the unfinished displacement of this segment, and outputs the positioning completion signal</li> <li>● The switching segment numbers must be in the following order:             <ol style="list-style-type: none"> <li>①The segment number switch is invalid before the positioning of the x-th segment is completed</li> <li>②During the x-th segment displacement operation or after the positioning is completed, turn off the multi-segment position command first, and then switch the segment number from x to y (if x=y, the driver will execute the x-segment displacement again)</li> <li>③After the x-th segment displacement positioning is completed, the multi-segment position command enable is set to ON, and the driver executes the y-th segment displacement</li> </ol> </li> </ul> |
|---|---|

When the multi-segment position operation mode is set to IN switching operation, please configure the 4 IN terminals of the drive (the number of IN terminals required can be set according to the actual number of running stages) as functions 14~17 (FunIN.13~FunIN.16: multi-segment position command switching), and confirm the valid logic of IN terminal.

★ Description of related parameters

| Code     | Name | Function name                               | Function   |      |                |      |      |                |   |   |   |   |   |   |   |   |   |   |       |  |  |  |  |   |   |   |   |    |   |   |   |   |    |
|----------|------|---|--|------|----------------|------|------|----------------|---|---|---|---|---|---|---|---|---|---|-------|--|--|--|--|---|---|---|---|----|---|---|---|---|----|
| FunIN.14 | CMD1 | Multi-segment operation command switching 1 | <p>The multi-segment segment number is a 4-digit binary number, and the corresponding relationship between CMD1 ~ CMD4 and the segment number is as follows:</p> <table border="1" style="margin-left: auto; margin-right: auto;"> <thead> <tr> <th>CMD4</th> <th>CMD3</th> <th>CMD2</th> <th>CMD1</th> <th>Segment number</th> </tr> </thead> <tbody> <tr> <td>0</td> <td>0</td> <td>0</td> <td>0</td> <td>1</td> </tr> <tr> <td>0</td> <td>0</td> <td>0</td> <td>1</td> <td>2</td> </tr> <tr> <td colspan="5" style="text-align: center;">.....</td> </tr> <tr> <td>1</td> <td>1</td> <td>1</td> <td>0</td> <td>15</td> </tr> <tr> <td>1</td> <td>1</td> <td>1</td> <td>1</td> <td>16</td> </tr> </tbody> </table> <p>The logic of the IN terminal is level valid, the CMD value is 1 when the input level is valid, otherwise it is 0</p> | CMD4 | CMD3           | CMD2 | CMD1 | Segment number | 0 | 0 | 0 | 0 | 1 | 0 | 0 | 0 | 1 | 2 | ..... |  |  |  |  | 1 | 1 | 1 | 0 | 15 | 1 | 1 | 1 | 1 | 16 |
| CMD4     | CMD3 | CMD2  |  | CMD1 | Segment number |      |      |                |   |   |   |   |   |   |   |   |   |   |       |  |  |  |  |   |   |   |   |    |   |   |   |   |    |
| 0        | 0    | 0   |  | 0    | 1              |      |      |                |   |   |   |   |   |   |   |   |   |   |       |  |  |  |  |   |   |   |   |    |   |   |   |   |    |
| 0        | 0    | 0   |  | 1    | 2              |      |      |                |   |   |   |   |   |   |   |   |   |   |       |  |  |  |  |   |   |   |   |    |   |   |   |   |    |
| .....    |      |   |  |      |                |      |      |                |   |   |   |   |   |   |   |   |   |   |       |  |  |  |  |   |   |   |   |    |   |   |   |   |    |
| 1        | 1    | 1   | 0  | 15   |                |      |      |                |   |   |   |   |   |   |   |   |   |   |       |  |  |  |  |   |   |   |   |    |   |   |   |   |    |
| 1        | 1    | 1   | 1  | 16   |                |      |      |                |   |   |   |   |   |   |   |   |   |   |       |  |  |  |  |   |   |   |   |    |   |   |   |   |    |
| FunIN.15 | CMD2 | Multi-segment operation command switching 2 |  |      |                |      |      |                |   |   |   |   |   |   |   |   |   |   |       |  |  |  |  |   |   |   |   |    |   |   |   |   |    |
| FunIN.16 | CMD3 | Multi-segment operation command switching 3 |  |      |                |      |      |                |   |   |   |   |   |   |   |   |   |   |       |  |  |  |  |   |   |   |   |    |   |   |   |   |    |
| FunIN.17 | CMD4 | Multi-segment operation command switching 4 |  |      |                |      |      |                |   |   |   |   |   |   |   |   |   |   |       |  |  |  |  |   |   |   |   |    |   |   |   |   |    |

② Set multi-segment position operation curve

The multi-segment position running function can set 16 different position commands, and the displacement, maximum running speed, acceleration and deceleration speed of each segment and the waiting time between segments can be set separately. Take the 1st segment as an example.

★ Description of related parameters

| Parm             | Name  | Setting range          | Unit         | Function   | Setting method   | Effective time | Factory setting |
|------------------|---|------------------------|--------------|--|------------------|----------------|-----------------|
| P09.12<br>P09.13 | Movement displacement of the 1st segment                            | -1073741824~1073741824 | Command unit | Set the sum of position commands in the 1st segment  | Set when running | Next run       | 10000           |
| P09.14           | Maximum operating speed of the 1st displacement                     | 0~6000                 | rpm          | Set the maximum operating speed of the 1st segment   | Set when running | Next run       | 200             |
| P09.15           | Acceleration and deceleration time constant of the 1st displacement | 1~65535                | ms           | Set the time for motor to change from 0rpm to 1000rpm in the 1st segment of the multi-segment position | Set when running | Next run       | 100             |
| P09.16           | Waiting time after the 1st segment of displacement is completed     | 0~65535                | ms(s)        | Set the waiting time after the 1st segment positioning is completed                                    | Set when running | Next run       | 100             |

According to the above settings, the actual operating curve of the motor is shown in the figure below:

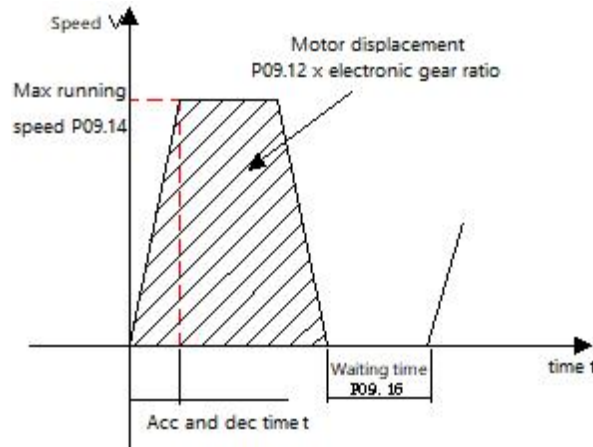

Therefore, the actual acceleration time  $t$  to P09.14 (the maximum operating speed of the 1st displacement):

$$t = \frac{P09.14}{1000} \times P09.15$$

For the setting of the remaining 15 parameters, please refer to the parameter descriptions in Chapter 6.

③ Multi-segment position command enable

When selecting multi-segment position command as the source of position command, please configure 1 IN terminal of the servo driver as function 21 (FunIN.21: multi-segment position command enable), and confirm the valid logic of IN terminal.

★ Description of related parameters

| Code     | Name     | Function name                         | Function  |
|----------|----------|---------------------------------------|---|
| FunIN.21 | PosInSen | Multi-segment position command enable | Valid: motor runs multi-stage position command<br>Invalid: the motor is in a locked state<br>Notice:<br>When P09.00=0/1, the logic of IN terminal corresponding to FunInSen signal is valid for level<br>When P09.00=2, the logic of IN terminal corresponding to FunInSen signal is valid along the change |

**d) The source of position command is communication control (P03.00=2)**

Under this position command source, the start and stop of the motor can be controlled through communication, and the corresponding parameters can also be set to make the motor work in continuous operation in one direction/reciprocating direction (demonstration operation mode) for debugging purposes or aging testing purposes.

★ Description of related parameters

| Parm             | Name                                     | Setting range | Unit         | Function   | Setting method   | Effective time        | Factory setting |
|------------------|--|---------------|--------------|--|------------------|-----------------------|-----------------|
| P04.60<br>P04.61 | Number of communication command pulses   | 0~1073741824  | Command unit | Set the number of command pulses for communication operation   | Set when running | Next run              | 50000           |
| P04.62           | Communication speed                      | 0~6000        | rpm          | Setting the maximum speed for communication operation  | Set when running | Next run              | 1000            |
| P04.63           | Communication acceleration time constant | 1~65535       | ms           | Set the time for the motor speed to accelerate uniformly from 0rpm to 1000rpm  | Set when running | Next run              | 200             |
| P04.64           | Communication deceleration time constant | 1~65535       | ms           | Set the time for the motor speed to decelerate uniformly from 1000rpm to 0rpm  | Set when running | Next run              | 200             |
| P04.65           | Internal demo operation mode             | 0~1           | -            | Set the operation mode of internal demo operation<br>0: Motor reciprocating<br>1: Motor runs in one direction                | Set when running | Next run              | 0               |
| P04.66           | Internal demo start running direction    | 0~1           | -            | Set the starting direction of the internal demo run<br>0: positive direction<br>1: negative direction                        | Set when running | Next run              | 0               |
| P04.67           | Number of internal demo runs             | 0~65535       | -            | Set the number of runs of internal demo run  | Set when running | Next run              | Next run        |
| P12.09           | Communication displacement mode          | 0~1           | -            | Set the type of position command for communication operation:<br>0 - Incremental position mode<br>1 - Absolute position mode | Set when running | Next run              | Next run        |
| P12.10           | Communication start/stop command         | 0~6           | -            | Start/stop command for driver communication operation  | Set when running | Next run              | 6               |
| P12.12           | Internal demo waiting time               | 0~65535       | ms           | Set the waiting time for internal demo operation   | Set when running | Next run              | 200             |
| P12.13           | Internal demo start/stop command         | 0~2           | -            | Start/stop command for internal demo operation of the driver   | Set when running | Effective immediately | 0               |
| P01.33           | Emergency stop                           | 1~65535       | ms           | When setting the emergency   | Set when         | Effective             | 30              |

|  |                            |  |  |  |         |             |  |
|--|----------------------------|--|--|--|---------|-------------|--|
|  | deceleration time constant |  |  | stop, the motor speed uniformly decelerates from 1000rpm to 0rpm | running | immediately |  |
|--|----------------------------|--|--|--|---------|-------------|--|

The startup method is as follows:

1、 The motor works in communication control mode: write the start and stop commands for operation through P12.10, and the motor will run in accordance with the operation curve determined by the command stroke, speed and acceleration/deceleration time constant set by P04.60~P04.64.

| Value written in P12.10 | Description   |
|-------------------------|---|
| 0                       | Write: trigger the motor to decelerate to stop. After the motor responds to the start-stop command, set P12.10 to 6;                                  |
| 1                       | Write: Trigger the motor to run forward of the command set by P04.60 and stop. After the motor responds to the start-stop command, set P12.10 to 6;   |
| 2                       | Write: Trigger the motor to run reversely of the command set by P04.60 and stop. After the motor responds to the start-stop command, set P12.10 to 6; |
| 3                       | Write: Trigger the motor to jog forward. After the motor responds to the start-stop command, set P12.10 to 6;   |
| 4                       | Write: Trigger the motor to jog reverse. After the motor responds to the start-stop command, set P12.10 to 6;   |
| 5                       | Write: trigger the emergency stop of the moto.. After the motor responds to the start-stop command, set P12.10 to 6;                                  |
| 6                       | Write: meaningless; Read: indicate that the motor is running or waiting to be triggered to run;   |

2、 The motor works in cyclic operation (demonstration) mode: write the start and stop instructions of the demonstration through P12.13. In the demo running mode, the motor will start in reciprocating or single direction (P04.65=0/1) according to the running command, speed, acceleration and deceleration time constant set by P04.60~P04.64, and start in positive or negative direction (P04.66=0/1), run the number of times set by P04.67. After completing the set running command each time and setting the delay time by P12.12, restart again and run in this cycle.

| Value written in P12.13 | Description  |
|-------------------------|--|
| 0                       | Write: stop the operation of the demo mode; read: indicate that the motor is waiting to be triggered to run;     |
| 1                       | Write: start the operation of the demo mode; set P12.13 to 2 after the motor responds to the start-stop command; |
| 2                       | Write: meaningless; Read: means that the motor is working in demo mode;  |

**e) The source of position command is communication trigger control (P03.00=4)**

Under this position command source, the relative stroke or absolute position parameter P03.58 of the operation can be written through communication (P03.57 is displayed on the LED display panel of the driver, and the position command stroke is composed of the two registers P03.57/P03.58 to form a signed 32-bit integer value, where P03.57 is the low 16-bit value, and P03.58 is the high 16-bit value. **The trigger mode of communication**

**control is to write the value of P03.58 (high 16 bits) by communication to start running**), when the motor is running, the upper computer can dynamically modify the stroke, speed, acceleration and deceleration through communication, and the driver responds to the operating parameters immediately.

★ Description of related parameters

| Parm             | Name                               | Setting range          | Unit         | Function  | Setting method     | Effective time        | Factory setting |
|------------------|------------------------------------|------------------------|--------------|---|--------------------|-----------------------|-----------------|
| P03.53           | Operating position mode            | 0~1                    | -            | Set the position mode of the driver operation<br>0: Incremental position mode<br>1: Absolute position mode  | Set after stopping | Effective immediately | 0               |
| P03.54           | Communication control acceleration | 1~65535                | ms           | Set the time to accelerate uniformly from 0rpm to 1000rpm   | Set when running   | Effective immediately | 100             |
| P03.55           | Communication control deceleration | 1~65535                | ms           | Set the time to decelerate uniformly from 1000rpm to 0rpm   | Set when running   | Effective immediately | 100             |
| P03.56           | Communication control speed        | 0~6000                 | rpm          | Set the speed of communication control operation  | Set when running   | Effective immediately | 500             |
| P03.57<br>P03.58 | Communication control position     | -1073741824~1073741824 | Command unit | Set the stroke/position of communication control operation<br>Pn229 is the high 16 bits, and Pn228 is the low 16 bits. Communication writing to Pn229 will immediately trigger a run (when the motor is stopped) or dynamically modify the running position (when the motor is running) | Set when running   | Effective immediately | 10000           |

- Write the high 16-bit register (P03.58) of the stroke/position through the host computer communication to realize the start of the motor;
- In the incremental position mode, when the motor is running and the reverse running stroke (P03.57/P03.58) is triggered by communication, the motor will run the user-set reverse stroke with the stop position as the starting point after decelerating and stopping according to the set deceleration time constants.

**f) The source of position command is fixed length/jog control(P03.00=5)**

When the position command source is set to fixed-length/jog control, it has the following functions:

- Control the motor's fixed-length forward and reverse through external input terminals
- Control motor jog forward and reverse through external input terminal
- Control motor jogging through external input terminals: start-stop + direction mode

**(1) Control the motor's fixed-length forward and reverse through external input terminals**

★ Description of related parameters

| Parm   | Name           | Setting range | Unit | Function                           | Setting method   | Effective time | Factory setting |
|--------|----------------|---------------|------|------------------------------------|------------------|----------------|-----------------|
| P04.20 | Point velocity | 0~6000        | rpm  | Set the maximum speed of operation | Set when running | Next run       | 200             |
| P04.22 | Point          | 1~65535       | ms   | Set the time for the motor         | Set when         | Next run       | 100             |

|                  |   |                            |              |   |                  |                       |       |
|------------------|---|----------------------------|--------------|---|------------------|-----------------------|-------|
|                  | acceleration                              |                            |              | speed to uniformly accelerate from 0rpm to 1000rpm  | running          |                       |       |
| P04.23           | Point deceleration                        | 1~65535                    | ms           | Set the time for the motor speed to decelerate uniformly from 1000rpm to 0rpm               | Set when running | Next run              | 100   |
| P04.24<br>P04.25 | Point stroke                              | -1073741824~<br>1073741824 | Command unit | Set the stroke/position of the motor running at a fixed length                              | Set when running | Next run              | 10000 |
| P01.33           | Emergency stop deceleration time constant | 1~65535                    | ms           | When setting the emergency stop, the motor speed uniformly decelerates from 1000rpm to 0rpm | Set when running | Effective immediately | 30    |

The start-up operation mode is as follows:

- 2、 Set the corresponding IN terminal function to "FunIN.27: USER4 (fixed length forward)", "FunIN.28: USER5 (fixed length reverse)" [P02 group: terminal input/output parameters](#), use external input to trigger the start.
- 3、 Note that: the trigger signal is an edge signal. Triggering the start again while the motor is running will not work. Similarly, if the trigger signal remains valid, the motor will still not respond to other operating modes in the command source after it stops.

## (2) Control motor jog forward and reverse through external input terminal

★ Description of related parameters

| Parm   | Name                                      | Setting range | Unit | Function  | Setting method   | Effective time        | Factory setting |
|--------|---|---------------|------|---|------------------|-----------------------|-----------------|
| P04.20 | Jog forward speed                         | 0~6000        | rpm  | Set the maximum speed of operation  | Set when running | Next run              | 200             |
| P04.21 | Jog reverse speed                         | 0~6000        | rpm  | Set the maximum speed of operation  | Set when running | Next run              | 200             |
| P04.22 | Jog acceleration                          | 1~65535       | ms   | Set the time for the motor speed to uniformly accelerate from 0rpm to 1000rpm               | Set when running | Next run              | 100             |
| P04.23 | Jog deceleration                          | 1~65535       | ms   | Set the time for the motor speed to decelerate uniformly from 1000rpm to 0rpm               | Set when running | Next run              | 100             |
| P01.33 | Emergency stop deceleration time constant | 1~65535       | ms   | When setting the emergency stop, the motor speed uniformly decelerates from 1000rpm to 0rpm | Set when running | Effective immediately | 30              |

The start-up operation mode is as follows:

- 1、 Set the corresponding IN terminal function to "FunIN.25: USER2 (jogging forward)", "FunIN.26: USER3 (jogging reverse)" [P02 group: terminal input/output parameters](#) , use external input to trigger the start (the trigger signal is level effective).

**(3) Control motor jogging through external input terminals: start-stop + direction mode**

★ Description of related parameters

| Parm   | Name                                      | Setting range | Unit | Function  | Setting method   | Effective time        | Factory setting |
|--------|---|---------------|------|---|------------------|-----------------------|-----------------|
| P04.20 | Jog forward speed                         | 0~6000        | rpm  | Set the maximum speed of operation  | Set when running | Next run              | 200             |
| P04.21 | Jog reverse speed                         | 0~6000        | rpm  | Set the maximum speed of operation  | Set when running | Next run              | 200             |
| P04.22 | Jog acceleration                          | 1~65535       | ms   | Set the time for the motor speed to uniformly accelerate from 0rpm to 1000rpm               | Set when running | Next run              | 100             |
| P04.23 | Jog deceleration                          | 1~65535       | ms   | Set the time for the motor speed to decelerate uniformly from 1000rpm to 0rpm               | Set when running | Next run              | 100             |
| P01.33 | Emergency stop deceleration time constant | 1~65535       | ms   | When setting the emergency stop, the motor speed uniformly decelerates from 1000rpm to 0rpm | Set when running | Effective immediately | 30              |

The start-up operation mode is as follows:

2、 Set the corresponding IN terminal function as "FunIN.24: USER1 (jogging start and stop)", "FunIN.18: torque command direction setting (jogging direction)" [P02 group: terminal input/output parameters](#), Use the external input to trigger the start and stop of the motor and control the direction of the motor (the trigger signal is level effective).

### 4.1.2 Electronic gear ratio

(1) **Electronic gear ratio concept**

In the position control mode, the input position command (command unit) is to set the load displacement, and the motor position command (encoder unit) is to set the motor displacement, in order to establish the proportional relationship between the motor position command and the input position command, the electronic gear ratio function is introduced.

Through the frequency division (electronic gear ratio<1) or frequency multiplication (electronic gear ratio>1) function of the electronic gear ratio, the actual displacement of the motor rotation or movement can be set when the input position command is 1 command unit.

★ Term explanation:

"Command unit": Refers to the minimum recognizable value input from the upper device to the driver.

"Encoder unit": refers to the value of the input command after processing the electronic gear ratio.

(2) **Setting steps of electronic gear ratio**

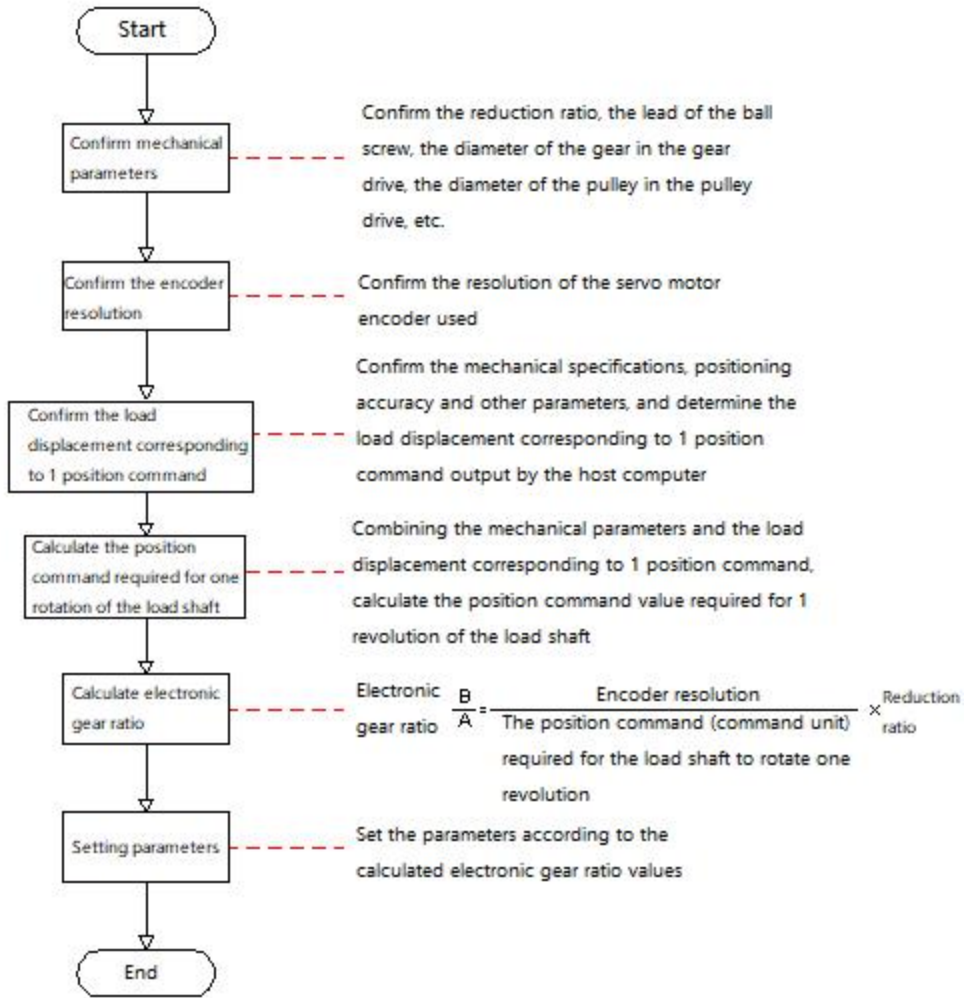

★ Description of related parameters

| Parm             | Name   | Setting range  | Unit | Function   | Setting method     | Effective time        | Factory setting |
|------------------|--|----------------|------|--|--------------------|-----------------------|-----------------|
| P03.06<br>P03.07 | Number of position commands for one motor rotation | 0~8388608      | p/r  | Set the number of position commands required for one rotation of motor                       | Set after stopping | Effective immediately | 10000           |
| P03.08<br>P03.09 | Electronic gear ratio 1 numerator                  | 1 ~ 1073741824 | -    | Set the numerator of electronic gear ratio 1<br>● Effective when P03.06/P03.07 is set to 0   | Set after stopping | Effective immediately | 1               |
| P03.10<br>P03.11 | Electronic gear ratio 1 denominator                | 1 ~ 1073741824 | -    | Set the denominator of electronic gear ratio 1<br>● Effective when P03.06/P03.07 is set to 0 | Set after stopping | Effective immediately | 1               |
| P03.12<br>P03.13 | Electronic gear ratio 2 numerator                  | 1 ~ 1073741824 | -    | Set the numerator of electronic gear ratio 2<br>● Effective when P03.06/P03.07 is set to 0   | Set after stopping | Effective immediately | 1               |
| P03.14<br>P03.15 | Electronic gear ratio 2 denominator                | 1 ~ 1073741824 | -    | Set the denominator of electronic gear ratio 2<br>● Effective when P03.06/P03.07 is set to 0 | Set after stopping | Effective immediately | 1               |

- **Note:** When P03.06 (number of position commands for one motor rotation) is set to other than 0, the electronic gear ratio  $\frac{A}{B} = \frac{\text{Encoder resolution}}{\text{P03.06}}$ , at this time, electronic gear ratio 1 (P03.08/P03.10) and electronic gear ratio 2 (P03.12/P03.14) have no effect.



### 4.1.3 Position command filtering

Position command filtering is to filter the position command (encoder unit) after the electronic gear ratio frequency division or frequency multiplication. The methods are average filtering and first-order low-pass filtering. In the following applications, you should consider adding position command filtering:

- The position command output by the host computer has not been processed for acceleration and deceleration
- Low pulse command frequency
- When the electronic gear ratio is more than 10 times
- ★ Description of related parameters

| Parm   | Name   | Setting range | Unit  | Function  | Setting method     | Effective time        | Factory setting |
|--------|--|---------------|-------|---|--------------------|-----------------------|-----------------|
| P03.04 | Position command average filter time constant              | 1~2048        | 0.1ms | Set the time constant for the average value filter of the position command (encoder unit) | Set after stopping | Effective immediately | 1               |
| P03.05 | Position command first-order low-pass filter time constant | 0~65535       | 0.1ms | Set the first-order low-pass filter time constant of position command                     | Set after stopping | Effective immediately | 0               |

- This function has no effect on the displacement (total number of position commands).
- If the set value is too large, the response delay will increase. The filter time constant should be set according to the actual situation.

### 4.1.4 Positioning complete signal

The positioning completion function means that the drive detects that the stop time of the position command exceeds the time set by the user (P03.21: Position command stop detection time), and the position deviation meets the condition set by the user (P03.22: Positioning completion threshold), and maintain for a certain time (P03.20: Arrival signal establishment time), until the position completion signal is output.

- ★ Description of related parameters

| Parm   | Name                                 | Setting range | Unit         | Function   | Setting method   | Effective time        | Factory setting |
|--------|--------------------------------------|---------------|--------------|--|------------------|-----------------------|-----------------|
| P03.20 | Arrival signal establishment time    | 0~65535       | 0.1ms        | Set the arrival establishment time when the motor arrival signal is output | Set when running | Effective immediately | 10              |
| P03.21 | Position command stop detection time | 0~65535       | 0.1ms        | Set the pulse stop detection time when the motor arrival signal is output  | Set when running | Effective immediately | 10              |
| P03.22 | Positioning completion threshold     | 1~65535       | Encoder unit | Set the positioning accuracy when the motor arrival signal is output       | Set when running | Effective immediately | 10              |

### 4.1.5 Homing function

#### (1) Function introduction

Origin: the mechanical origin, which can be expressed as the origin switch signal or limit switch signal, set by the parameter P03.41 (homing mode selection).

Zero point: the positioning target point, which can be expressed as origin + offset (P03.46/P03.47: mechanical origin offset). When the offset is set to 0, the zero point coincides with the origin.

The homing function is the function of triggering the return-to-origin function when the driver is enabled, the motor will actively find the zero point to complete the positioning.

During the homing operation, other position commands (including the retriggered homing enable signal) are shielded; after the homing operation is completed, the driver can respond to other position commands.

The homing function includes two modes: home return to zero and electrical return to zero.

Home return to zero: After the driver receives the origin return trigger signal, it will actively locate the relative position of the motor shaft and the mechanical origin according to the preset mechanical origin. First find the origin, and then move the offset based on the origin to reach the zero position. The zero point return is usually used when searching for zero point for the first time.

Electrical return to zero: After the zero position is determined by the home return to zero operation, the current position is used as the starting point to move a certain relative displacement.

After the home return is completed (including home return to zero and electrical return to zero), the current position of the motor (P13.07/P13.08: position command counter) is the same as the mechanical home offset (P03.46/P03.47: mechanical home offset).

After the home return is completed, the driver outputs the home return to zero completion signal, and the upper computer can confirm the home return completion after receiving the signal.

## (2) Home return to zero

The following cases are used as examples to illustrate the operation mode of home return to zero:

- **Forward home return: deceleration point, home point as home switch (P03.41 = 0)**
- **Forward home return: deceleration point and home point are forward limit switches (P03.41 = 2)**
- **Forward return home: deceleration point and home position are mechanical limit positions (P03.41 = 4)**

### (a) Forward home return: deceleration point, home point as home switch (P03.41 = 0)

① **The home switch (deceleration point) signal is invalid (0 - invalid, 1 - valid) before the motor returns to the home position, and the positive limit switch is not triggered in the whole process**

The motor first searches for the deceleration point signal in the forward direction at the set value of P03.42 (speed of high-speed search for home switch signal) until it encounters the rising edge of the deceleration point. After decelerating to 0 according to the deceleration time constant set in P03.44 (acceleration/deceleration time constant for low-speed search home switch signal), it reverses the acceleration to the set value of -P03.43 (speed of low-speed search home switch signal) and searches for the deceleration point signal falling edge at low speed. When it encounters the falling edge of the deceleration point signal, it will decelerate and stop, and then continue to search for the rising edge of the deceleration point in the low-speed forward direction with the set value of P03.43. During forward acceleration or forward uniform speed operation, the machine will stop immediately when it encounters the rising edge signal of the origin signal.

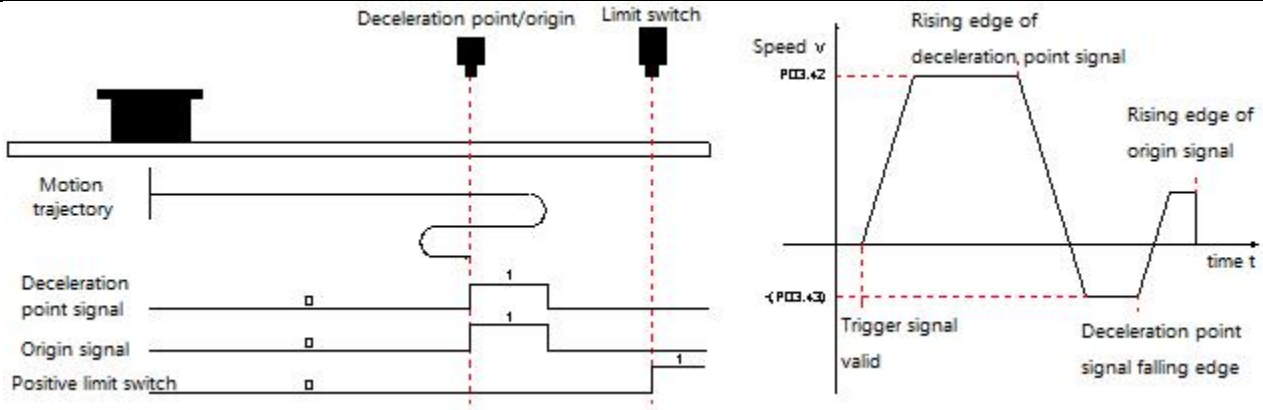

**② The home switch (deceleration point) signal is valid (0 - invalid, 1 - valid) before the motor returns to the home position, and the positive limit switch is not triggered in the whole process**

The motor directly searches for the falling edge of the deceleration point signal in the reverse direction at the set value of -P03.43 (low speed search for the origin switch signal), and decelerates to stop when it encounters the falling edge of the deceleration point signal, and then continues to search for the rising edge of the deceleration point signal in the forward direction with the set value of P03.43, and stops immediately when it encounters the rising edge of the home signal in the forward direction of acceleration or uniform speed operation.

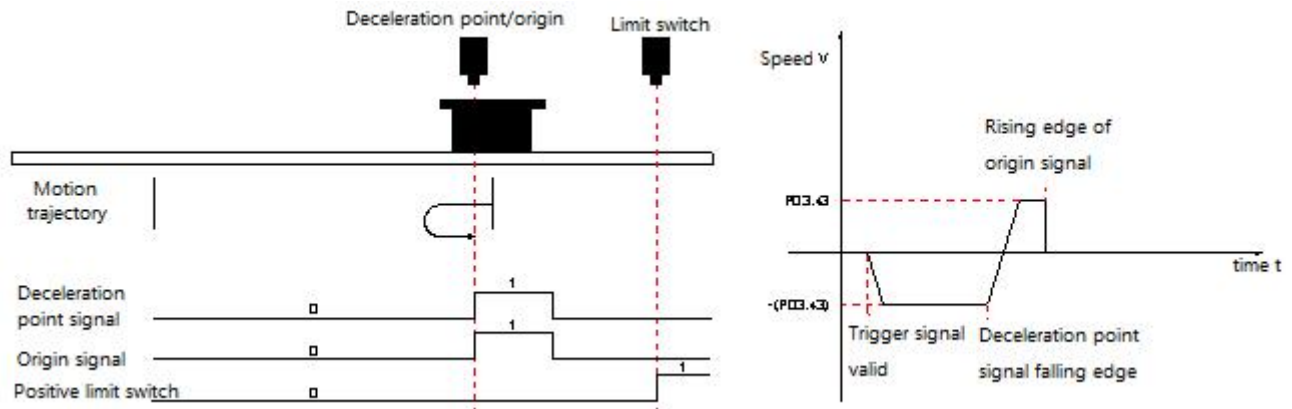

**③ Home switch (deceleration point) signal is invalid (0- invalid, 1- valid) before the motor returns to the home position, and the positive limit switch is triggered during the process of returning to the home position**

The motor first searches for the deceleration point signal in the forward direction with the set value of P03.42 (speed of high-speed search for home switch signal), and stops after encountering the positive limit switch and decelerating to 0 according to the deceleration time constant set in P01.33 (emergency stop deceleration time constant). And in accordance with P03.49 (mechanical origin offset and limit processing method), immediately return to the origin in reverse direction (P03.49=2/3), or stop and wait for the upper device to give the trigger signal to return to the home position again (P03.49=0/1). After the conditions are met, the motor searches for the falling edge of the deceleration point signal in the reverse direction with the set value of -P03.42. After encountering the deceleration point signal falling edge, decelerate the speed to 0 in accordance with the deceleration time set by P03.44 (acceleration and deceleration time constant of searching for the original switch signal), and then forward accelerate to the set value of P03.43 (speed of searching for the original switch signal)

at low speed), and forward accelerate or forward uniformly in operation, and stop immediately when encountering the signal of the rising edge of the original signal.

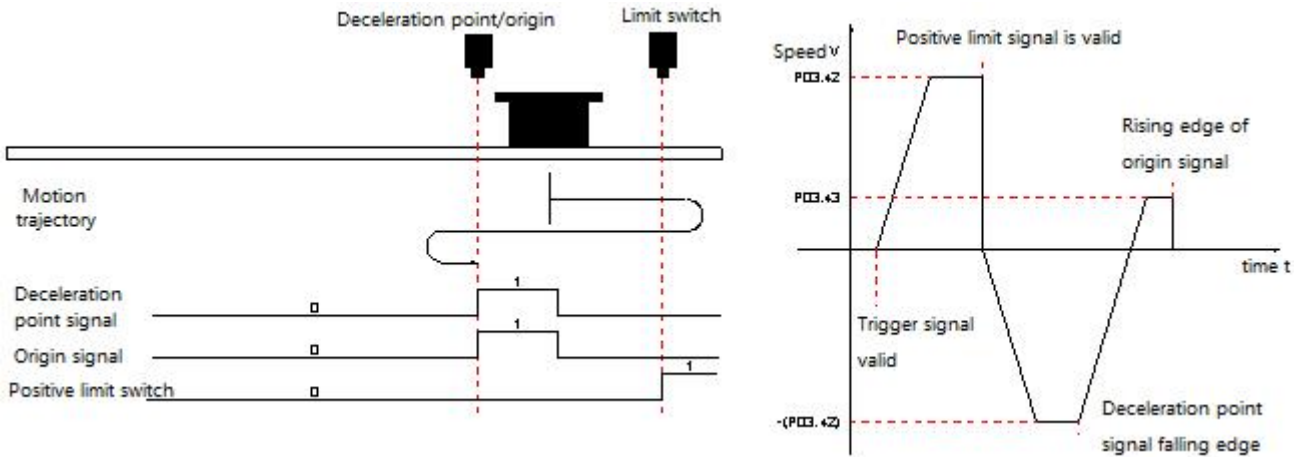

**(b) Forward home return: deceleration point and home point are forward limit switches (P03.41 = 2)**

**① Positive limit switch (deceleration point) is invalid (0 - invalid, 1 - valid) before the motor returns to the home position**

The motor first searches for the deceleration point signal in the forward direction at the value set in P03.42 (speed of searching for the home switch signal at high speed) until it encounters the rising edge of the deceleration point. After decelerating to 0 according to the deceleration time set in P03.44 (acceleration/deceleration time constant for searching the home switch signal), the motor accelerates in the reverse direction to the value set in -P03.43 (speed for searching the home switch signal at low speed) and searches for the deceleration point signal falling edge at low speed. When it encounters the falling edge of the deceleration point signal, it will decelerate to stop and stop, and then continue to search for the rising edge of the deceleration point in the low-speed forward direction with the set value of P03.43. During forward acceleration or forward uniform speed operation, will stop immediately when it encounters the rising edge signal of the positive limit switch signal.

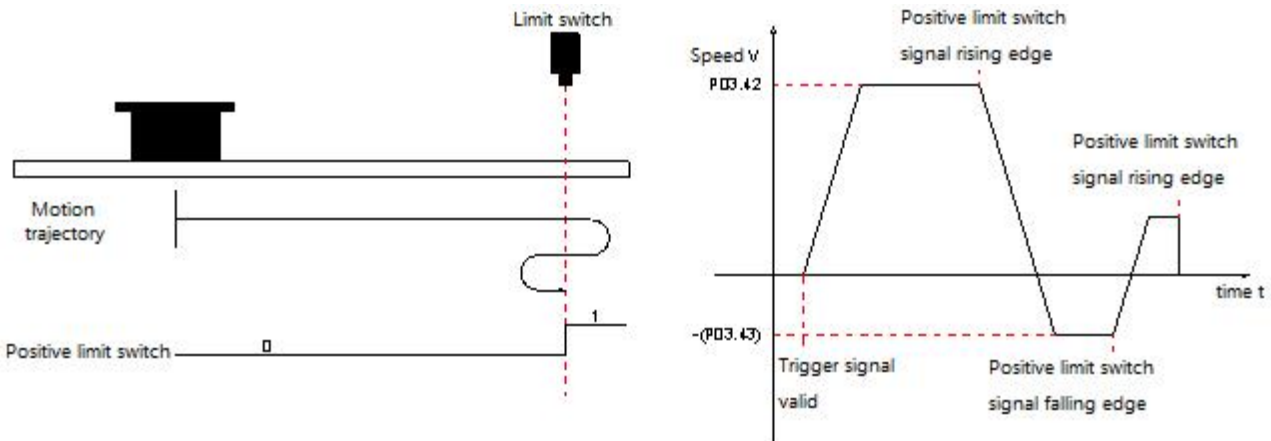

**② Positive limit switch (deceleration point) is valid (0 - invalid, 1 - valid) before the motor returns to the home position**

The motor directly searches for the falling edge of the deceleration point signal in the reverse direction at the set value of -P03.43 (low speed search for the origin switch signal), and immediately decelerates to stop when it encounters the falling edge of the deceleration point signal, and then continues to search for the rising edge of the deceleration point signal in the forward direction with the set value of P03.43, and stops immediately when it

encounters the rising edge of the forward limit switch signal during positive acceleration or uniform speed operation.

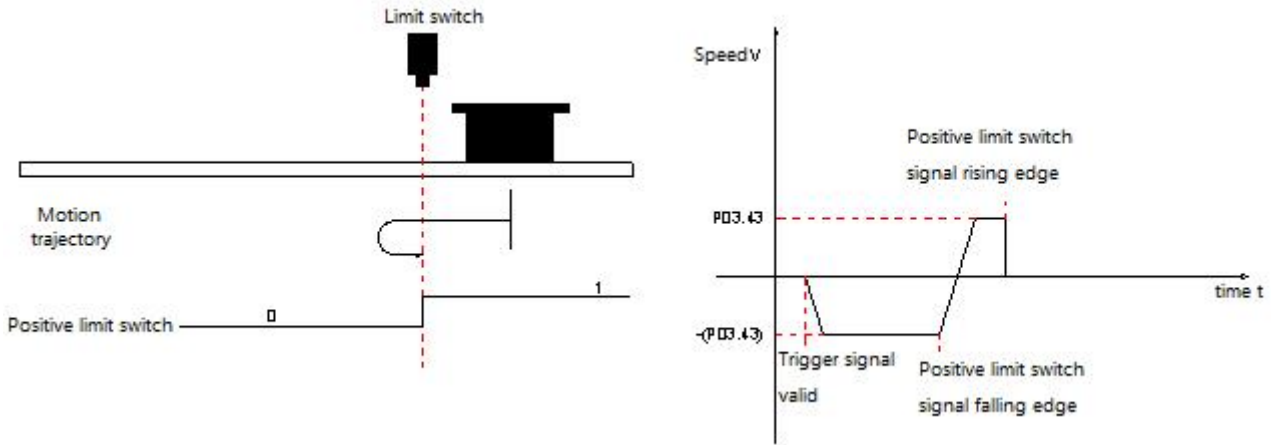

**(c) Forward return home: deceleration point and home position are mechanical limit positions (P03.41 = 4)**

The motor first runs at low speed in the positive direction with the set value of P03.43 (speed of low-speed search home switch signal), and after collision to the mechanical limit position, if the motor torque reaches P03.52 (trigger stop and return to zero torque limit) and the actual motor speed is lower than P03.51 (the threshold value for the judgment of the return-to-zero speed when the stop is triggered), and this state is maintained for a certain time P03.50 (the threshold for the judgment of the return-to-zero time when the stop is reached), it is judged that the motor runs to the mechanical limit position and stops immediately.

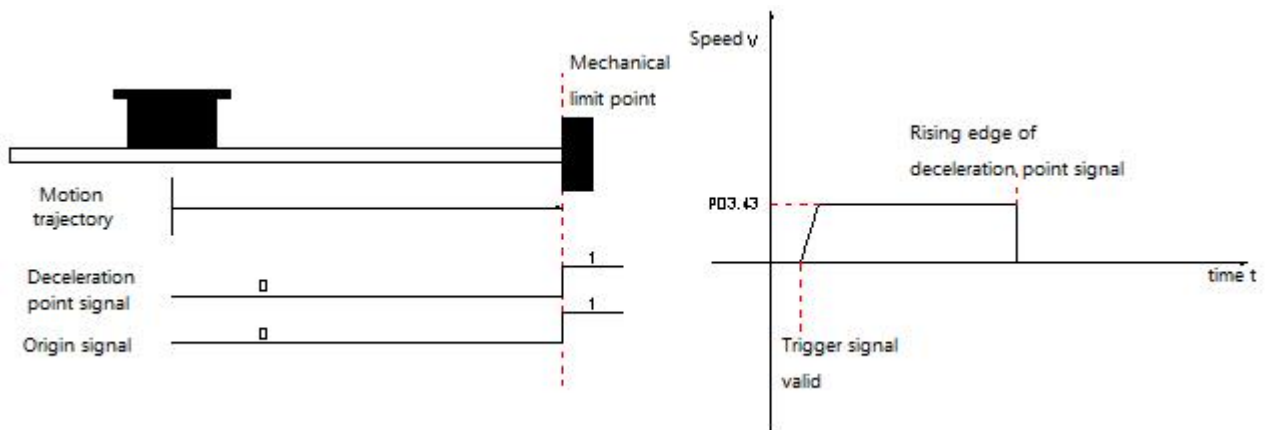

**(3) Electrical return to zero**

The mechanical zero position of the system is known after the motor has undergone a mechanical zero return operation. At this time, after setting P03.46/P03.47, the motor can be moved from the current position (P13.07/P13.08) to the specified position (P03.46/P03.47). In the electrical return to zero mode, the motor runs at high speed at the set value of P03.42 (speed of high-speed search home switch signal) throughout the entire process, and the total motor displacement is determined by the difference between P13.07/P13.08 and P03.46/P03.47, and the running direction is determined by the positive or negative of the total motor displacement. After the displacement command is completed, the motor will stop.

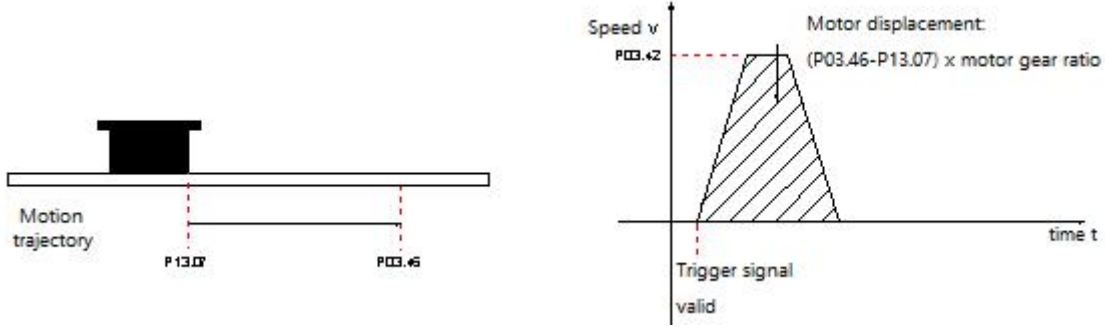

**(4) Mechanical origin and mechanical zero point**

Take P03.41=0 as an example to illustrate the difference between mechanical origin and mechanical zero point:

| The mechanical origin does not coincide with the mechanical zero point   | The mechanical origin coincides with the mechanical zero point  |
|--|---|
| <p>If the home position offset (P03.46/P03.47) is set and the mechanical origin does not coincide with the mechanical zero point (P03.49 = 0/2), during forward acceleration or forward uniform operation, the motor stops immediately after encountering the rising edge of the home position signal. And the current position of the motor P13.07/P13.08 is forced to the set value of P03.46/P03.47 after stopping.</p> | <p>If the home position offset (P03.46/P03.47) is set and the mechanical origin coincides with the mechanical zero point (P03.49 = 1/3), the motor stops immediately after encountering the rising edge of the home position signal during forward acceleration or forward uniform speed operation. After that, the motor stops after running the stroke of the set value P03.46/P03.47. At this time, the current position of the motor P13.07/P13.08 and the set value of P03.46/P03.47 are the same.</p> |
|  |   |

## 4.2 Speed control mode

Set the value of parameter P01.00 to 1, to enable the driver to work in speed control mode.

### 1.1.1 Speed command input setting

In speed control mode, the source of speed command should be set by parameter P04.00 first.

★ Description of related parameters

| Parm   | Name                           | Setting range   | Function   | Setting method     | Effective time        | Factory setting |
|--------|--------------------------------|---|--|--------------------|-----------------------|-----------------|
| P04.00 | Speed command source selection | 0: Digital given<br>1: Multi-segment speed command<br>2: Communication control<br>3: IO control<br>4: Analog control (reserved)<br>5~10: Reserved | Set the source of speed commands in speed control mode | Set after stopping | Effective immediately | 0               |

#### a) Speed command source is digital given (P04.00=0)

★ Description of related parameters

| Parm   | Name                                      | Setting range | Unit | Function  | Setting method   | Effective time        | Factory setting |
|--------|---|---------------|------|---|------------------|-----------------------|-----------------|
| P04.01 | Speed command digital given value         | -6000~6000    | rpm  | Set the maximum speed of motor operation<br><b>Speed is a signed value, a positive number means positive rotation, a negative number means reverse rotation</b> | Set when running | Effective immediately | 1000            |
| P04.05 | Speed command acceleration time constant  | 1~65535       | ms   | Set the time for the motor speed to uniformly accelerate from 0rpm to 1000rpm   | Set when running | Effective immediately | 200             |
| P04.06 | Speed command deceleration time constant  | 1~65535       | ms   | Set the time for the motor speed to decelerate uniformly from 1000rpm to 0rpm   | Set when running | Effective immediately | 200             |
| P01.33 | Emergency stop deceleration time constant | 1~65535       | ms   | Set the time for the motor speed to uniformly decelerate from 1000rpm to 0rpm during emergency stop   | Set when running | Effective immediately | 30              |

The start-up operation mode is as follows:

- 1、 The motor starts to run when the servo is enabled, that is, the driver start and stop are controlled by the driver enable signal.
  - The motor can modify the running speed through communication during operation, and it will take effect immediately;

- When the motor encounters a limit or emergency stop input, it will decelerate to stop according to the emergency stop deceleration time constant set by P01.33. And after stopping, even if the limit or emergency stop input signal becomes invalid, the motor will not start to run, and it must be re-enabled to trigger the motor's operation;
- The motor can select the running direction by setting the input terminal function to "FunIN.19 (speed command direction setting)". The actual running direction of the motor is as follows:

| P01.01<br>(Rotation direction selection) | P04.01<br>(Speed command digital given value) | Speed command direction setting | The actual running speed of the motor |
|--|---|---------------------------------|---------------------------------------|
| 0  | +   | invalid                         | CCW                                   |
|  | +   | valid                           | CW                                    |
|  | -   | invalid                         | CW                                    |
|  | -   | valid                           | CCW                                   |
| 1  | +   | invalid                         | CW                                    |
|  | +   | valid                           | CCW                                   |
|  | -   | invalid                         | CCW                                   |
|  | -   | valid                           | CW                                    |

**b) Speed command source is multi-segment speed command (P04.00=1)**

The servo driver has the function of multi-segment speed operation. It means that there are 16 speed commands stored inside the servo driver, and the maximum operating speed and operating time of each segment can be set separately. And equipped with 7 groups of acceleration and deceleration time to choose from. The setting process is as follows:

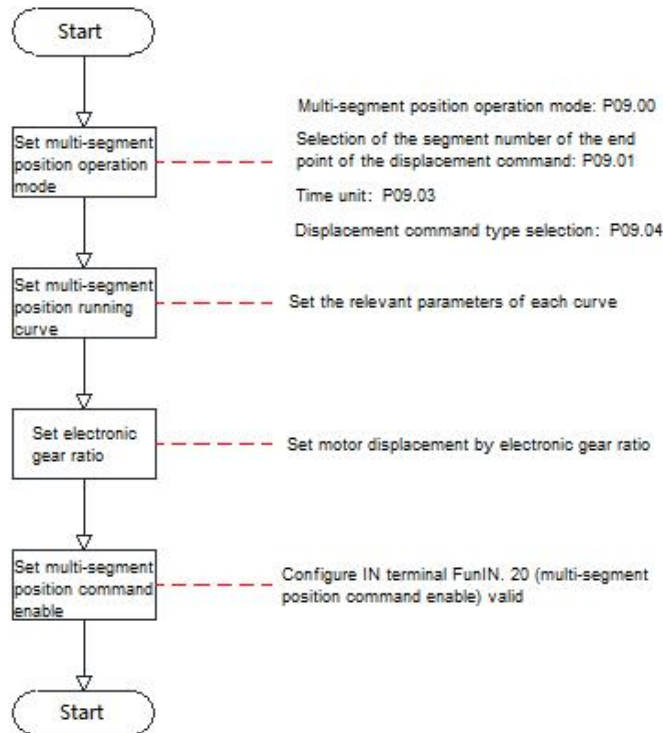



① Set multi-speed operation mode

★ Description of related parameters

| Parm   | Name   | Setting range  | Function   | Setting method   | Effective time | Factory setting |
|--------|--|--|--|------------------|----------------|-----------------|
| P10.00 | Multi-segment speed command operation method | 0: stop at the end of a single operation<br>1: Cycle operation<br>2: Switch through the external IN port | Set multi-speed command operation mode                             | Set when running | Next run       | 1               |
| P10.01 | Number of speed command end segments         | 1~16   | Set the number of segments required for a multi-step speed command | Set when running | Next run       | 16              |
| P10.02 | Unit of running time                         | 0: ms<br>1: s  | Selects the unit of multi-segment speed command running time       | Set when running | Next run       | 0               |

The external IN terminal can be configured with the function FunIN.19 (speed command direction setting) for multi-segment operation command direction selection.

| Code     | Function name                   | Function   |
|----------|---------------------------------|--|
| FunIN.19 | Speed command direction setting | Invalid: default command direction<br>Valid: the opposite direction of the command |

Take P10.01=2 as an example to illustrate each mode:

- Stop at the end of a single operation (P10.00=0)

P10.00 is set to 0 and the single run end stop mode is selected. After setting parameters P10.01 and P10.02 respectively according to the total number of executed segments and execution time units, and setting parameters such as command value, running time and acceleration/deceleration time of the corresponding segment according to the demand, the driver will run from segment 1 to segment N according to the segment code until it stops after running the last segment.

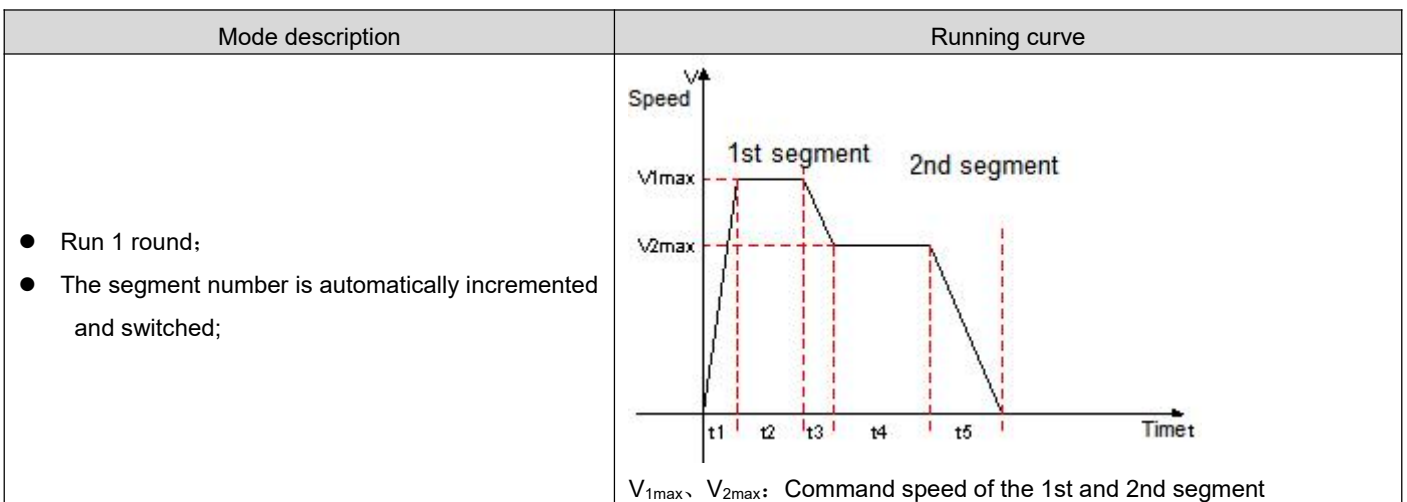

|  |   |
|--|---|
|  | <p><math>t_1</math>: The actual acceleration and deceleration time of the first segment;<br/> <math>t_3</math>、<math>t_5</math>: The actual acceleration and deceleration time of the second segment;<br/>                 A certain period of running time: the shifting time of the previous speed command switching to this speed command + the constant speed running time of this segment(for example: the running time of the first segment in the figure is <math>t_1+t_2</math>, and the running time of the second segment is <math>t_3+t_4</math>. And so on)<br/>                 When a certain period of running time is set to 0, the driver will skip this segment speed command and execute the next segment.</p> |
|--|---|

★ Term explanation:

The total number of multi-segment speed commands set by P10.01 when the driver completes one run is called the completion of one round of operation.。

● Cycle operation (P10.00=1)

P10.00 is set to 1, and the cycle operation mode is selected.

After setting the parameters P10.01 and P10.02 according to the total number of execution segments and execution time unit, and set the command value, running time and acceleration/deceleration time of the corresponding segment according to the requirements, the module will run time and acceleration/deceleration time according to the commands of each segment. The drive will run according to the speed segment from the 1st segment to the Nth segment, and automatically jump to the 1st segment for cyclic operation after the last segment.

| Mode description  | Running curve  |
|---|--|
| <ul style="list-style-type: none"> <li>● Cycle operation, the starting segment number of each round is 1;</li> <li>● The segment number is automatically incremented and switched;</li> <li>● If the servo enable is valid, the cycle running state will always be maintained.</li> </ul> | <p><math>V_{1max}</math>、<math>V_{2max}</math>: Command speed of the 1st and 2nd segment<br/>                 A certain period of running time: the shifting time of the previous speed command switching to this speed command + the constant speed running time of this segment(for example: the running time of the first segment in the figure is <math>t_1+t_2</math>, and the running time of the second segment is <math>t_3+t_4</math>. And so on)<br/>                 When a certain period of running time is set to 0, the driver will skip this segment speed command and execute the next segment.</p> |

● Switch through the external IN port (P10.00=2)

P10.00 is set to 2 to select the external IN port switching mode.

After setting the P10.01 parameter according to the total number of execution segments, and set the corresponding segment command value, running time, acceleration and deceleration time and other parameters according to the requirements, the driver will select the speed command value of the corresponding segment number according to the ON/OFF combination of external IN (multi-segment operation command switch x).

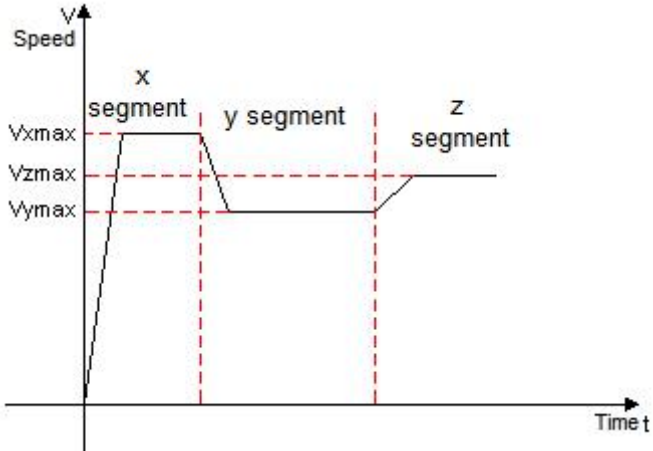
| Mode description   | Running curve   |
|--|---|
| <ul style="list-style-type: none"> <li>● If the segment number is updated, it can run continuously;</li> <li>● The segment number is determined by the IN terminal logic</li> <li>● The interval time between segments is determined by the command delay of the host computer;</li> <li>● If the servo enable is valid, the cycle running state will always be maintained.</li> </ul> |  <p>x, y: segment number, the logical relationship between segment number and IN terminal is as follows;<br/>The running time of a certain segment is not affected by the parameter setting value. During the speed command operation of a certain segment, if the segment number changes, it will immediately switch to the new segment number to run;</p> |

When the multi-segment position operation mode is set to IN switching operation, please configure the 4 IN terminals of the driver as functions 14~17 (FunIN.14~FunIN.17: multi-segment operation command switching), and confirm the valid logic of IN terminal. At the same time, one IN terminal of the servo driver can be configured as function 19 (FunIN.19: speed command direction setting) to switch the speed command direction.

| Code     | Name    | Function name                               | Function  |      |                |      |      |                |   |   |   |   |   |   |   |   |   |   |       |  |  |  |  |   |   |   |   |    |   |   |   |   |    |
|----------|---------|---|---|------|----------------|------|------|----------------|---|---|---|---|---|---|---|---|---|---|-------|--|--|--|--|---|---|---|---|----|---|---|---|---|----|
| FunIN.14 | CMD1    | Multi-segment operation command switching 1 | The multi-segment segment number is a 4-digit binary number, and the corresponding relationship between CMD1 ~ CMD4 and the segment number is as follows: <table border="1" data-bbox="743 1518 1366 1821"> <thead> <tr> <th>CMD4</th> <th>CMD3</th> <th>CMD2</th> <th>CMD1</th> <th>Segment number</th> </tr> </thead> <tbody> <tr> <td>0</td> <td>0</td> <td>0</td> <td>0</td> <td>1</td> </tr> <tr> <td>0</td> <td>0</td> <td>0</td> <td>1</td> <td>2</td> </tr> <tr> <td colspan="5" style="text-align: center;">.....</td> </tr> <tr> <td>1</td> <td>1</td> <td>1</td> <td>0</td> <td>15</td> </tr> <tr> <td>1</td> <td>1</td> <td>1</td> <td>1</td> <td>16</td> </tr> </tbody> </table> | CMD4 | CMD3           | CMD2 | CMD1 | Segment number | 0 | 0 | 0 | 0 | 1 | 0 | 0 | 0 | 1 | 2 | ..... |  |  |  |  | 1 | 1 | 1 | 0 | 15 | 1 | 1 | 1 | 1 | 16 |
| CMD4     | CMD3    | CMD2  |   | CMD1 | Segment number |      |      |                |   |   |   |   |   |   |   |   |   |   |       |  |  |  |  |   |   |   |   |    |   |   |   |   |    |
| 0        | 0       | 0   |   | 0    | 1              |      |      |                |   |   |   |   |   |   |   |   |   |   |       |  |  |  |  |   |   |   |   |    |   |   |   |   |    |
| 0        | 0       | 0   |   | 1    | 2              |      |      |                |   |   |   |   |   |   |   |   |   |   |       |  |  |  |  |   |   |   |   |    |   |   |   |   |    |
| .....    |         |   |   |      |                |      |      |                |   |   |   |   |   |   |   |   |   |   |       |  |  |  |  |   |   |   |   |    |   |   |   |   |    |
| 1        | 1       | 1   | 0   | 15   |                |      |      |                |   |   |   |   |   |   |   |   |   |   |       |  |  |  |  |   |   |   |   |    |   |   |   |   |    |
| 1        | 1       | 1   | 1   | 16   |                |      |      |                |   |   |   |   |   |   |   |   |   |   |       |  |  |  |  |   |   |   |   |    |   |   |   |   |    |
| FunIN.15 | CMD2    | Multi-segment operation command switching 2 |   |      |                |      |      |                |   |   |   |   |   |   |   |   |   |   |       |  |  |  |  |   |   |   |   |    |   |   |   |   |    |
| FunIN.16 | CMD3    | Multi-segment operation command switching 3 |   |      |                |      |      |                |   |   |   |   |   |   |   |   |   |   |       |  |  |  |  |   |   |   |   |    |   |   |   |   |    |
| FunIN.17 | CMD4    | Multi-segment operation command switching 4 |   |      |                |      |      |                |   |   |   |   |   |   |   |   |   |   |       |  |  |  |  |   |   |   |   |    |   |   |   |   |    |
| FunIN.19 | DIR-SEL | Speed command direction setting             | In multi-segment IN switching operation mode, used to set the speed command direction<br>Invalid: keep the original command direction<br>Effective: speed command direction   |      |                |      |      |                |   |   |   |   |   |   |   |   |   |   |       |  |  |  |  |   |   |   |   |    |   |   |   |   |    |

② Set multi-speed operation curve

Take the first stage speed command as an example, the relevant parameters are as follows:

★ Description of related parameters

| Parm   | Name  | Setting range | Unit             | Function  | Setting method   | Effective time        | Factory setting |
|--------|---|---------------|------------------|---|------------------|-----------------------|-----------------|
| P10.03 | Acceleration time constant 1  | 1~65535       | ms               | Set the first group acceleration and deceleration time constant | Set when running | Effective immediately | 200             |
| P10.04 | Deceleration time constant 1  | 1~65535       | ms               |   | Set when running | Effective immediately | 200             |
| P10.15 | Acceleration time constant 7  | 1~65535       | ms               | Set the 7th group acceleration and deceleration time constant   | Set when running | Effective immediately | 200             |
| P10.16 | Deceleration time constant 7  | 1~65535       | ms               |   | Set when running | Effective immediately | 200             |
| P10.20 | The first segment speed command   | -6000~6000    | rpm              | Set the first segment speed command value                       | Set when running | Effective immediately | 100             |
| P10.21 | The first segment speed command running time  | 0~65535       | 0.1sec<br>0.1min | Set the first segment command running time                      | Set when running | Effective immediately | 10              |
| P10.22 | The first segment speed command acceleration and deceleration time constant selection | 1~7           | -                | Select the first segment acceleration and deceleration mode     | Set when running | Effective immediately | 1               |

There are 7 groups of acceleration and deceleration time for selection in the multi-segment speed command parameters, except for the 1 to 16 segments of command value and command running time. The default mode is acceleration and deceleration time constant 1. In the multi-segment speed, P10.00=1, the end of a single operation is taken as an example, and the actual acceleration and deceleration time and running time are explained:

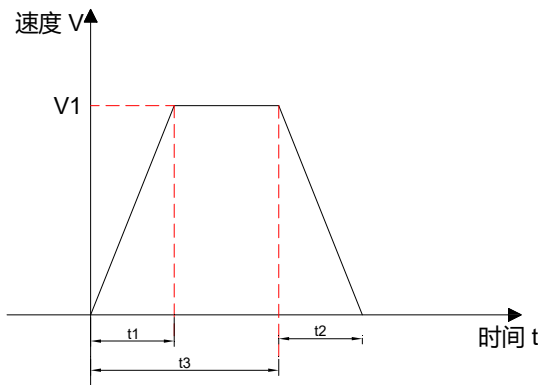

As shown in the figure above, the speed command of this segment is V1, and the actual acceleration time t1 is:

$$t_1 = \frac{V_1}{1000} \times \text{The acceleration time of the speed setting}$$

Actual deceleration time t2:

$$t_2 = \frac{V_1}{1000} \times \text{The deceleration time of this speed setting}$$

Running time: the shift time when the previous speed command is switched to this speed command + the constant speed running time of this segment, as shown in t3 in the figure.

**c) The speed command source is the communication control speed command (P04.00=2)**

★ Description of related parameters

| Parm             | Name   | Setting range | Unit         | Function  | Setting method   | Effective time        | Factory setting |
|------------------|--|---------------|--------------|---|------------------|-----------------------|-----------------|
| P04.60<br>P04.61 | Number of communication command pulses           | 0~1073741824  | Command unit | Set the number of command pulses for communication control operation  | Set when running | Effective immediately | 50000           |
| P04.62           | Communication control speed                      | 0~6000        | rpm          | Set the maximum speed for communication control operation   | Set when running | Effective immediately | 1000            |
| P04.63           | Communication control acceleration time constant | 1~65535       | ms           | Set the time for the motor speed to uniformly accelerate from 0rpm to 1000rpm                                 | Set when running | Effective immediately | 200             |
| P04.64           | Communication control deceleration time constant | 1~65535       | ms           | Set the time for the motor speed to uniformly decelerate from 1000rpm to 0rpm                                 | Set when running | Effective immediately | 200             |
| P04.65           | Internal demo operation mode                     | 0~1           | -            | Set the operation mode of internal demo operation<br>0: Motor reciprocating<br>1: Motor runs in one direction | Set when running | Effective immediately | 0               |
| P04.66           | Internal demo start running direction            | 0~1           | -            | Set the starting direction of the internal demo run<br>0: positive direction<br>1: negative direction         | Set when running | Effective immediately | 0               |
| P04.67           | Number of internal demo runs                     | 0~65535       | -            | Set the number of runs of internal demo run   | Set when running | Effective immediately | 0               |
| P12.10           | Communication control start/stop command         | 0~6           | -            | Start/stop command for driver communication operation   | Set when running | Effective immediately | 6               |
| P12.12           | Internal demo waiting time                       | 0~65535       | ms           | Set the waiting time for the internal demo operation  | Set when running | Effective immediately | 100             |
| P12.13           | Internal demo start/stop command                 | 0~2           | -            | Start /stop command for the internal demo operation of the driver   | Set when running | Effective immediately | 0               |
| P01.33           | Emergency stop deceleration time constant        | 1~65535       | ms           | Set the time for the motor speed to uniformly decelerate from 1000rpm to 0rpm during emergency stop           | Set when running | Effective immediately | 30              |

The startup method is as follows:

3. The motor works in the communication control mode: write the start and stop commands for operation through P12.10, and the motor will run in accordance with the operation curve determined by the command stroke, speed and acceleration/deceleration time constant set by P04.60~P04.64.

| Value written in P12.10 | Description  |
|-------------------------|--|
| 0                       | Write: trigger motor to decelerate to stop. After the motor responds to the start-stop command, set P12.10 to 6;   |
| 1                       | Write: trigger the motor to run forward of the operation command set by P04.60 and then stop. After the motor responds to the start-stop command, set P12.10 to 6;   |
| 2                       | Write: trigger the motor to run reversely of the operation command set by P04.60 and then stop. After the motor responds to the start-stop command, set P12.10 to 6; |
| 3                       | Write: trigger the motor to jog forward. After the motor responds to the start-stop command, set P12.10 to 6;  |
| 4                       | Write: trigger the motor to jog reverse. After the motor responds to the start-stop command, set P12.10 to 6;  |
| 5                       | Write: trigger motor emergency stop. After the motor responds to the start-stop command, set P12.10 to 6;  |
| 6                       | Write: meaningless; Read: indicating that the motor is running or waiting to be triggered to run;  |

4. The motor works in cyclic operation (demonstration) mode: write the start and stop instructions of the demonstration through P12.13. In the demo running mode, the motor will start in reciprocating or single direction (P04.65=0/1) according to the running command, speed, acceleration and deceleration time constant set by P04.60~P04.64, and start in positive or negative direction (P04.66=0/1), run the number of times set by P04.67. After completing the set running command each time and setting the delay time by P12.12, restart again and run in this cycle.

| Value written in P12.13 | Description  |
|-------------------------|--|
| 0                       | Write: stop the operation of the demo mode; read: indicate that the motor is waiting to be triggered to run;     |
| 1                       | Write: start the operation of the demo mode; set P12.13 to 2 after the motor responds to the start-stop command; |
| 2                       | Write: meaningless; Read: means that the motor is working in demo mode;  |

**d) The speed command source is IO jog (P04.00=3)**

★ Description of related parameters

| Parm   | Name                  | Setting range | Unit | Function  | Setting method   | Effective time        | Factory setting |
|--------|-----------------------|---------------|------|---|------------------|-----------------------|-----------------|
| P04.16 | IO jog forward speed  | 0~6000        | rpm  | Set the maximum speed of the motor running forward    | Set when running | Effective immediately | 200             |
| P04.17 | IO jog reversal speed | 0~6000        | rpm  | Set the maximum speed of the motor running in reverse | Set when running | Effective immediately | 200             |
| P04.18 | IO jog                | 1~65535       | ms   | Set the time for the motor speed to                   | Set when         | Next run              | 100             |

|        |   |         |    |   |                  |                       |     |
|--------|---|---------|----|---|------------------|-----------------------|-----|
|        | acceleration time constant                |         |    | uniformly accelerate from 0rpm to 1000rpm   | running          |                       |     |
| P04.19 | IO jog deceleration time constant         | 1~65535 | ms | Set the time for the motor speed to uniformly decelerate from 1000rpm to 0rpm                       | Set when running | Next run              | 100 |
| P01.33 | Emergency stop deceleration time constant | 1~65535 | ms | Set the time for the motor speed to uniformly decelerate from 1000rpm to 0rpm during emergency stop | Set when running | Effective immediately | 30  |

The startup method is as follows:

1. The motor works in: start-stop + direction mode

Set the function of the input terminal to control the motor, assuming that IN3 controls the start and stop of the motor, and IN4 controls the direction of the motor:

| Code     | Name    | Function name                   | Function  |
|----------|---------|---------------------------------|---|
| FunIN.24 | USER1   | Motor start and stop            | IN3 is used to control the start and stop of the motor: Pn02.04=24<br>Normally open polarity (when IN3 is connected to 0V, the motor will start, and when IN3 is connected to 24V, the motor will stop): Pn02.05=0<br>Normally closed polarity (the motor stops when IN3 is connected to 0V, and the motor starts when IN3 is connected to 24V): Pn02.05=1            |
| FunIN.19 | DIR-SEL | Speed command direction setting | IN4 is used to control the running direction of the motor: Pn02.06=19<br>Normally open polarity (when IN4 is connected to 0V, the motor is reversed, when IN4 is connected to 24V, the motor is forward): Pn02.07=0<br>Normally closed polarity (when IN4 is connected to 0V, the motor rotates forward, when IN4 is connected to 24V, the motor reverses): Pn02.07=1 |

The actual running direction of the motor is as follows:

| P01.01(Rotation direction selection) | Speed command direction setting | The actual running speed of the motor |
|--------------------------------------|---------------------------------|---------------------------------------|
| 0                                    | invalid                         | CCW                                   |
|                                      | valid                           | CW                                    |
|                                      | invalid                         | CW                                    |
|                                      | valid                           | CCW                                   |
| 1                                    | invalid                         | CW                                    |
|                                      | valid                           | CCW                                   |
|                                      | invalid                         | CCW                                   |
|                                      | valid                           | CW                                    |

2. The motor works in: forward rotation + reverse rotation mode

Set the function of the input terminal to control the motor, assuming that IN3 controls the motor to rotate forward, and IN4 controls the motor to reverse:

| Code     | Name  | Function name | Function   |
|----------|-------|---------------|--|
| FunIN.25 | USER2 | Motor forward | IN3 is used to control the start and stop of the motor: Pn02.04=25<br>Normally open polarity (when IN3 is connected to 0V, the motor rotates forward, when IN3 is connected to 24V, the motor stops): Pn02.05=0<br>Normally closed polarity (when IN3 is connected to 0V, the motor stops, |

|          |       |               |   |
|----------|-------|---------------|---|
|          |       |               | when IN3 is connected to 24V, the motor rotates forward): Pn02.05=1   |
| FunIN.26 | USER3 | Motor reverse | IN4 is used to control the running direction of the motor: Pn02.06=26<br>Normally open polarity (when IN4 is connected to 0V, the motor reverses, and when IN4 is connected to 24V, the motor stops): Pn02.07=0<br>Normally closed polarity (the motor stops when IN4 is connected to 0V, and the motor reverses when IN4 is connected to 24V): Pn02.07=1 |

Note: The motor will not respond to the speed start and stop command in the other direction during operation. For example: the motor is rotating forward at this time, even if the reverse signal is valid at this time, the motor will continue to rotate forward. If you really need to reverse, please cancel the forward signal first, and then input the reverse signal.

3. During the operation of the motor, the motor speed can be modified in real time by means of communication, and the driver can respond immediately.

### 4.3 Torque Control Mode

#### 4.3.1 Torque command input setting

In the torque control mode, the speed command source should first be set via parameter P05.00.

★ Related parameter description

| Parameter | Name                    | Setting range | Function   | Setting method     | Effective time        | Factory setting |
|-----------|-------------------------|---------------|--|--------------------|-----------------------|-----------------|
| P05.00    | Torque command source A | 0~2           | Set the command source of torque command source A<br>0: Digital setting (P05.03)<br>1: Analog channel AI1 (reserved)<br>2: Analog channel AI2 (reserved)   | Set after stopping | Effective immediately | 0               |
| P05.01    | Torque command source B | 0~2           | Set the command source of torque command source B<br>0: Digital setting (P05.03)<br>1: Analog channel AI1 (reserved)<br>2: Analog channel AI2 (reserved)   | Set after stopping | Effective immediately | 0               |
| P05.02    | Torque command source   | 0~3           | Set the torque command source in torque mode<br>0: Torque command is set by command source A<br>1: Torque command is set by command source B<br>2: Torque command is given by (P05.20) communication<br>3: Torque command is combined by command source A/B (reserved) | Set after stopping | Effective immediately | 0               |



**a) Torque operating mode 1**

In this working mode, the positive and negative symbols of the torque command are used to realize the forward and reverse operation of the motor torque mode, and there is no acceleration and deceleration control process for the operation of the motor. This function requires P05.26 to be set to 0.

★ Related parameter description

| Parameter | Name   | Setting range | Unit   | Function   | Setting method     | Effective time | Factory setting |
|-----------|--|---------------|--------|--|--------------------|----------------|-----------------|
| P05.03    | Digital given                                    | -3000~3000    | 0.1%   | When the command source P05.00/P05.01 is set to 0 (when digital is given), set the torque value for torque mode operation          | Set when running   | Next run       | 200             |
| P05.05    | Torque ramp                                      | 1~65535       | 0.1%/s | Set the unit time increment of torque command  | Set when running   | Next run       | 3000            |
| P05.12    | Speed limit source                               | 0~1           | -      | Set the maximum speed limit source in torque mode<br>0: Internal setting (P05.14/P05.15)<br>1: External analog quantity (reserved) | Set when running   | Next run       | 0               |
| P05.14    | Torque control forward speed limit value         | 0~6000        | rpm    | Set the forward speed limit value in torque control mode   | Set when running   | Next run       | 3000            |
| P05.15    | Torque control negative speed limit value        | 0~6000        | rpm    | Set the negative speed limit value in torque control mode  | Set when running   | Next run       | 3000            |
| P05.16    | Torque reaches the reference value               | 0~65535       | 0.1%   | Set the reference value of the motor torque when the running torque reaches the signal output                                      | Set when running   | Next run       | 0               |
| P05.17    | Torque reaches the effective value               | 0~65535       | 0.1%   | Set the effective value of the motor torque when the running torque reaches the signal output                                      | Set when running   | Next run       | 100             |
| P05.18    | Torque reaches invalid value                     | 0~65535       | 0.1%   | Set the invalid value of the motor torque when the running torque reaches the signal output  | Set when running   | Next run       | 50              |
| P05.19    | Torque mode torque arrival signal detection time | 0~65535       | ms     | Set the torque detection time of the motor torque when the running torque reaches the signal output                                | Set when running   | Next run       | 50              |
| P05.20    | Communication given torque command               | 0~3000        | 0.1%   | When P05.02 is set to 3, set the torque command value in torque mode   | Set when running   | Next run       | 200             |
| P05.26    | Torque operation mode selection                  | 0~1           | -      | Set the working mode of torque operation   | Set after stopping | Next run       | 0               |

Starting mode: After the above-mentioned related parameters are set for the motor, the upper computer will give an enable signal, and the motor torque will run according to the set torque and speed limit values.

**b) Torque operating mode 2**

In this working mode, the motor accelerates and decelerates according to the set speed trajectory, and the speed curve of the motor operation is planned. After the motor torque is reached, the internal operation mode can be selected, such as free running state, continuing to maintain the set torque, etc.

★ Related parameter description

| Parameter | Name   | Setting range | Unit | Function   | Setting method   | Effective time | Factory setting |
|-----------|--|---------------|------|--|------------------|----------------|-----------------|
| P05.03    | Digital given                                    | -3000~3000    | 0.1% | When the command source P05.00/P05.01 is set to 0 (when digital is given), set the torque value for torque mode operation          | Set when running | Next run       | 200             |
| P05.12    | Speed limit source                               | 0~1           | -    | Set the maximum speed limit source in torque mode<br>0: Internal setting (P05.14/P05.15)<br>1: External analog quantity (reserved) | Set when running | Next run       | 0               |
| P05.14    | Torque control forward speed limit value         | 0~6000        | rpm  | Set the forward speed limit value in torque control mode   | Set when running | Next run       | 3000            |
| P05.15    | Torque control negative speed limit value        | 0~6000        | rpm  | Set the negative speed limit value in torque control mode  | Set when running | Next run       | 3000            |
| P05.16    | Torque reaches the reference value               | 0~65535       | 0.1% | Set the reference value of the motor torque when the running torque reaches the signal output                                      | Set when running | Next run       | 0               |
| P05.17    | Torque reaches the effective value               | 0~65535       | 0.1% | Set the effective value of the motor torque when the running torque reaches the signal output                                      | Set when running | Next run       | 100             |
| P05.18    | Torque reaches invalid value                     | 0~65535       | 0.1% | Set the invalid value of the motor torque when the running torque reaches the signal output  | Set when running | Next run       | 50              |
| P05.19    | Torque mode torque arrival signal detection time | 0~65535       | ms   | Set the torque detection time of the motor torque when the running torque reaches the signal output                                | Set when running | Next run       | 50              |
| P05.20    | Communication given torque                       | 0~3000        | 0.1% | When P05.02 is set to 3, set the torque command value in   | Set when         | Next run       | 200             |

|        | command                                      |         |    | torque mode   | running            |                       |     |
|--------|--|---------|----|---|--------------------|-----------------------|-----|
| P05.21 | Torque running acceleration time constant    | 1~65535 | ms | Set the time for the motor speed to accelerate uniformly from 0rpm to 1000rpm   | Set when running   | Next run              | 100 |
| P05.22 | Torque running deceleration time constant    | 1~65535 | ms | Set the time for the motor speed to decelerate uniformly from 1000rpm to 0rpm   | Set when running   | Next run              | 100 |
| P05.23 | Torque mode torque holding time              | 0~65535 | ms | Set the torque holding time after the motor torque reaches the effective signal output<br>0: the motor holds the torque and waits for the upper computer to control the shutdown<br>Other values: After the motor holding torque reaches the time set in P05.23, it will stop automatically                               | Set when running   | Next run              | 500 |
| P05.24 | Torque mode shutdown mode                    | 0~4     | -  | Set the operating mode after torque stop in torque control mode:<br>0: Motor running torque is set to 0 (offline)<br>Other: Do not deal with  | Set when running   | Next run              | 0   |
| P05.25 | Torque mode communication start-stop command | 0~2     | -  | Used for communication to trigger the start and stop of the motor torque mode, or for software to force the motor torque to run in forward and reverse rotation (at this time, the motor start/stop is only controlled by the servo enable signal)<br>0: Stop<br>1: Forward start operation<br>2: Reverse start operation | Set when running   | Effective immediately | 0   |
| P05.26 | Torque operation mode selection              | 0~1     | -  | Set the working mode of torque operation  | Set after stopping | Next run              | 0   |

There are two ways to start up as follows:

- 1、 Set the corresponding IN terminal function to "FunIN.24 (torque forward)", "FunIN.25 (torque reverse)" [P02 group: terminal input/output parameters](#) and set the correct polarity according to the external IN terminal. Use external input to trigger torque mode operation (trigger signal is level effective).

2、 Write a specific value to P05.25 through communication:

| Value written in P05.25 | Description  |
|-------------------------|--|
| 0                       | Write: Torque operation stops; Read: indicates that the motor is in stop or has been stopped;    |
| 1                       | Write: Motor starting torque forward operation; Read: the motor is running torque forward        |
| 2                       | Write: Motor starting torque reverse operation; Read: the motor is in torque reversal operation; |

- In communication mode, when the motor torque is running, if you want to switch the running direction, you must first write 0 to trigger the motor to stop, then write the running start value in the opposite direction (1/2);
- It is recommended not to mix the external input trigger control and communication trigger control, otherwise there may be abnormal conditions.

### 1.1.2 Speed limit in torque mode

In the torque control mode, if the given torque command is too large and greater than the mechanical side load torque, the motor will continue to accelerate, overspeed may occur, and the mechanical equipment may be damaged. Therefore, in order to protect the machine, the speed of the motor must be limited.

★ Related parameter description

| Parameter | Name                                      | Setting range | Unit | Function  | Setting method   | Effective time | Factory setting |
|-----------|---|---------------|------|---|------------------|----------------|-----------------|
| P05.14    | Torque control forward speed limit value  | 0~6000        | rpm  | Set the forward speed limit value in torque control mode  | Set when running | Next run       | 3000            |
| P05.15    | Torque control negative speed limit value | 0~6000        | rpm  | Set the negative speed limit value in torque control mode | Set when running | Next run       | 3000            |

### 1.1.3 Torque arrival output

The torque arrival function is used to determine whether the actual torque command has reached the set interval. When the actual torque command reaches the torque command threshold, the driver can output the corresponding output signal (torque arrival) for the host computer to use the input/output parameters. [P02 group: terminal input/output parameters](#)

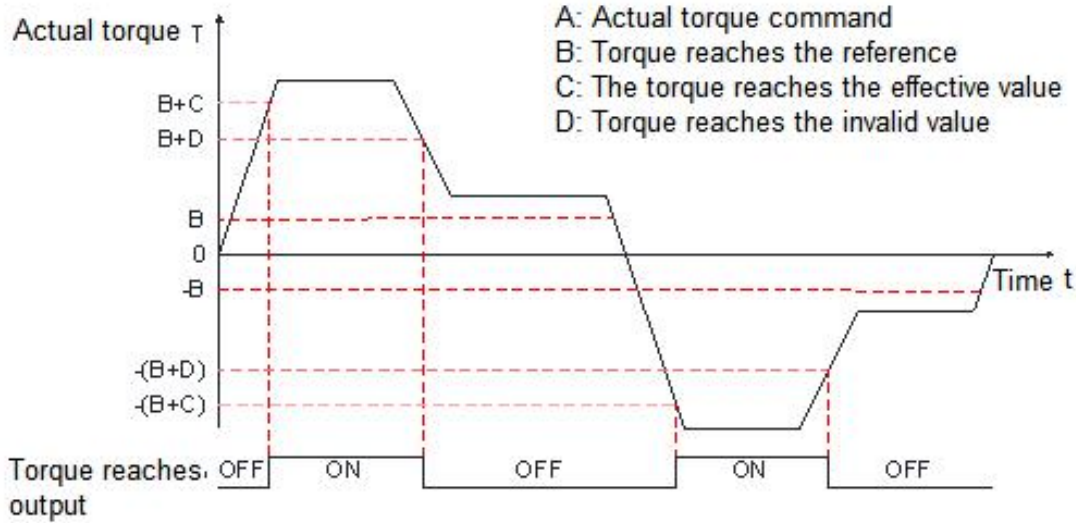

Actual torque command (P13.03 parameter value can be read by communication):

When the torque reaches the output signal from invalid to active, the actual torque command must satisfy:

$$|A| \geq B + C$$

Otherwise, the torque arrival output signal remains inactive.

Conversely, when the torque arrival signal changes from a valid value to an invalid value, the actual torque command must satisfy:

$$|A| < B + D$$

Otherwise, the torque arrival output signal remains active.

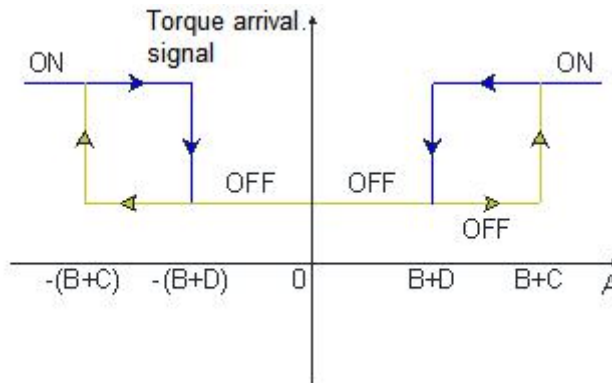

★ Related parameter description

| Parameter | Name                               | Setting range | Unit | Function  | Setting method   | Effective time | Factory setting |
|-----------|------------------------------------|---------------|------|---|------------------|----------------|-----------------|
| P05.17    | Torque reaches the effective value | 0~65535       | 0.1% | Set the effective value of the motor torque when the running torque reaches the signal output | Set when running | Next run       | 100             |
| P05.18    | Torque reaches invalid value       | 0~65535       | 0.1% | Set the invalid value of the motor torque when the running torque reaches the signal output   | Set when running | Next run       | 50              |
| P05.19    | Torque mode                        | 0~65535       | ms   | Set the torque detection time of  | Set              | Next run       | 50              |

|  |   |  |  |  |                 |  |  |
|--|---|--|--|--|-----------------|--|--|
|  | torque arrival<br>signal<br>detection<br>time |  |  | the motor torque when the<br>running torque reaches the<br>signal output | when<br>running |  |  |
|--|---|--|--|--|-----------------|--|--|

### 4.4 Hybrid control mode

The hybrid control mode means that when the servo enable bit is ON and the servo state is running, the working mode of the servo driver can be switched between different control modes.

There are four main types of mixed control modes:

- Speed mode – Torque mode
- Position mode – Speed mode
- Position mode – Torque mode
- Position mode – Speed mode – Torque mode

Set by parameter P01.00 (control mode selection), as shown in the following table:

★ Related parameter description

| Parameter | Name                   | Setting range  | Function                                 | Setting method     | Effective time        | Factory setting |
|-----------|------------------------|--|--|--------------------|-----------------------|-----------------|
| P01.00    | Control mode selection | 0: Position control mode<br>1: Speed control mode<br>2: Torque control mode<br>3: EtherCAT/CANopen mode<br>4: Speed mode – Torque mode<br>5: Position mode – Speed mode<br>6: Position mode – Torque mode<br>7: Position mode – Speed mode – Torque mode | Set the control mode of the servo driver | Set after stopping | Effective immediately | 0               |

When P01.00 is set to 4/5/6, please configure an IN terminal of the servo driver as function 10 (FunIN.10: control mode selection 1), and determine the effective logic level value of the IN terminal.

When P01.00 is set to 7, please configure the two IN terminals of the servo driver as function 10 (FunIN.10: control mode selection 1) and function 29 (FunIN.29: control mode selection 2) respectively. And determine the effective logic level of these two IN terminals.

★ Associated function code

| Code     | Name                     | Function  |                |                       |                       |
|----------|--------------------------|---|----------------|-----------------------|-----------------------|
| FunIN.10 | Control mode selection 1 | Used to set the current control mode of servo driver in mixed control mode: |                |                       |                       |
|          |                          | P01.00  | FunIN.10 logic | Control model         |                       |
|          |                          | 4   | Invalid        | Speed control mode    |                       |
|          |                          |   | Effective      | Torque control mode   |                       |
|          |                          | 5   | Invalid        | Position control mode |                       |
|          |                          |   | Effective      | Speed control mode    |                       |
|          |                          | 6   | Invalid        | Position control mode |                       |
|          |                          |   | Effective      | Torque control mode   |                       |
| FunIN.29 | Control mode selection 2 | Used to set the current control mode of servo driver in mixed control mode: |                |                       |                       |
|          |                          | P01.00  | FunIN.29 logic | FunIN.10 logic        | Control model         |
|          |                          | 7   | Invalid        | Invalid               | Position control mode |
|          |                          |   | Invalid        | Effective             | Speed control mode    |
|          |                          |   | Effective      | -                     | Torque control mode   |

## Chapter 5 Parameter Description

| Parameter group | Parameter group description       |
|-----------------|-----------------------------------|
| P00             | Servo driver/motor parameters     |
| P01             | Basic control parameters          |
| P02             | Terminal input/output parameters  |
| P03             | Position control parameters       |
| P04             | Speed control parameters          |
| P05             | Torque control parameters         |
| P06             | Gain parameters                   |
| P08             | Communication parameters          |
| P09             | Multi-segment position parameters |
| P10             | Multi-segment speed parameters    |
| P13             | Monitoring parameter groups       |

### 5.1 Group P00: Servo driver/motor parameters

|        |               |              |      |   |                 |       |
|--------|---------------|--------------|------|---|-----------------|-------|
| P00.00 | Name          | Motor number |      |   | Related mode    | -     |
|        | Setting range | 10000~65535  | Unit | - | Factory setting | 50604 |

|        |               |                    |      |   |                 |         |
|--------|---------------|--------------------|------|---|-----------------|---------|
| P00.01 | Name          | Servo driver model |      |   | Related mode    | display |
|        | Setting range | -                  | Unit | - | Factory setting | -       |

Display servo driver model

| Display value | Description |
|---------------|-------------|
| 0x42(66)      | DRV400E     |
| 0x43(67)      | DRV750E     |
| 0x45(69)      | DRV1500E    |
| 0x52(66)      | DRV400      |
| 0x53(67)      | DRV750      |
| 0x55(69)      | DRV1500     |
| 0x62(66)      | DRV400C     |
| 0x63(67)      | DRV750C     |
| 0x65(69)      | DRV1500C    |

|        |               |                             |      |   |                 |         |
|--------|---------------|-----------------------------|------|---|-----------------|---------|
| P00.02 | Name          | MCU software version number |      |   | Related mode    | display |
|        | Setting range | XXX.YY                      | Unit | - | Factory setting | -       |



|        |               |                       |      |   |                 |         |
|--------|---------------|-----------------------|------|---|-----------------|---------|
| P00.03 | Name          | FPGA software version |      |   | Related mode    | display |
|        | Setting range | XXX.YY                | Unit | - | Factory setting | -       |

|        |               |                           |      |   |                 |         |
|--------|---------------|---------------------------|------|---|-----------------|---------|
| P00.04 | Name          | EtherCAT software version |      |   | Related mode    | display |
|        | Setting range | XXX.YY                    | Unit | - | Factory setting | -       |

|        |               |                         |      |   |                 |         |
|--------|---------------|-------------------------|------|---|-----------------|---------|
| P00.05 | Name          | Driver hardware version |      |   | Related mode    | display |
|        | Setting range | XXX.YY                  | Unit | - | Factory setting | -       |

|        |               |                      |      |   |                 |         |
|--------|---------------|----------------------|------|---|-----------------|---------|
| P00.06 | Name          | CAN software version |      |   | Related mode    | display |
|        | Setting range | XXX.YY               | Unit | - | Factory setting | -       |

|        |               |                          |      |   |                 |         |
|--------|---------------|--------------------------|------|---|-----------------|---------|
| P00.07 | Name          | Software non-standard ID |      |   | Related mode    | display |
|        | Setting range | -                        | Unit | - | Factory setting | -       |

|        |               |                          |      |   |                 |         |
|--------|---------------|--------------------------|------|---|-----------------|---------|
| P00.08 | Name          | Hardware non-standard ID |      |   | Related mode    | display |
|        | Setting range | -                        | Unit | - | Factory setting | -       |

|        |               |                        |      |   |                 |         |
|--------|---------------|------------------------|------|---|-----------------|---------|
| P00.09 | Name          | Driver PWM update mode |      |   | Related mode    | display |
|        | Setting range | -                      | Unit | - | Factory setting | -       |

|        |               |             |      |        |                 |   |
|--------|---------------|-------------|------|--------|-----------------|---|
| P00.17 | Name          | Rated power |      |        | Related mode    | - |
|        | Setting range | 1~65535     | Unit | 0.01KW | Factory setting | - |

|        |               |               |      |   |                 |   |
|--------|---------------|---------------|------|---|-----------------|---|
| P00.18 | Name          | Rated voltage |      |   | Related mode    | - |
|        | Setting range | 1~380         | Unit | V | Factory setting | - |

|        |               |               |      |      |                 |   |
|--------|---------------|---------------|------|------|-----------------|---|
| P00.19 | Name          | Rated current |      |      | Related mode    | - |
|        | Setting range | 1~65535       | Unit | 0.1A | Factory setting | - |

|        |               |             |      |     |                 |   |
|--------|---------------|-------------|------|-----|-----------------|---|
| P00.20 | Name          | Rated speed |      |     | Related mode    | - |
|        | Setting range | 1~6000      | Unit | rpm | Factory setting | - |

|        |               |               |      |     |                 |   |
|--------|---------------|---------------|------|-----|-----------------|---|
| P00.21 | Name          | Maximum speed |      |     | Related mode    | - |
|        | Setting range | 1~6000        | Unit | rpm | Factory setting | - |

|        |               |              |      |        |                 |   |
|--------|---------------|--------------|------|--------|-----------------|---|
| P00.22 | Name          | Rated torque |      |        | Related mode    | - |
|        | Setting range | 1~65535      | Unit | 0.01Nm | Factory setting | - |

|        |               |                |      |        |                 |   |
|--------|---------------|----------------|------|--------|-----------------|---|
| P00.23 | Name          | Maximum torque |      |        | Related mode    | - |
|        | Setting range | 1~65535        | Unit | 0.01Nm | Factory setting | - |

|        |               |                      |      |                   |                 |   |
|--------|---------------|----------------------|------|-------------------|-----------------|---|
| P00.24 | Name          | Moment of inertia Jm |      |                   | Related mode    | - |
|        | Setting range | 1~65535              | Unit | kgcm <sup>2</sup> | Factory setting | - |

|        |               |                            |      |           |                 |   |
|--------|---------------|----------------------------|------|-----------|-----------------|---|
| P00.25 | Name          | Motor magnetic pole number |      |           | Related mode    | - |
|        | Setting range | 2~360                      | Unit | pole pair | Factory setting | - |

|        |               |                   |      |        |                 |   |
|--------|---------------|-------------------|------|--------|-----------------|---|
| P00.26 | Name          | Stator resistance |      |        | Related mode    | - |
|        | Setting range | 1~65535           | Unit | 0.001Ω | Factory setting | - |

|        |               |                      |      |        |                 |   |
|--------|---------------|----------------------|------|--------|-----------------|---|
| P00.27 | Name          | Stator inductance Lq |      |        | Related mode    | - |
|        | Setting range | 1~65535              | Unit | 0.01mH | Factory setting | - |

|        |               |                      |      |        |                 |   |
|--------|---------------|----------------------|------|--------|-----------------|---|
| P00.28 | Name          | Stator inductance Ld |      |        | Related mode    | - |
|        | Setting range | 1~65535              | Unit | 0.01mH | Factory setting | - |

|        |               |                             |      |            |                 |   |
|--------|---------------|-----------------------------|------|------------|-----------------|---|
| P00.29 | Name          | Linear back-EMF coefficient |      |            | Related mode    | - |
|        | Setting range | 1~65535                     | Unit | 0.01mV/rpm | Factory setting | - |

|        |               |                       |      |             |                 |   |
|--------|---------------|-----------------------|------|-------------|-----------------|---|
| P00.30 | Name          | Torque coefficient Kt |      |             | Related mode    | - |
|        | Setting range | 1~65535               | Unit | 0.01Nm/Arms | Factory setting | - |

|        |               |                           |      |        |                 |   |
|--------|---------------|---------------------------|------|--------|-----------------|---|
| P00.31 | Name          | Electric time constant Te |      |        | Related mode    | - |
|        | Setting range | 1~65535                   | Unit | 0.01ms | Factory setting | - |

|        |               |                             |      |        |                 |   |
|--------|---------------|-----------------------------|------|--------|-----------------|---|
| P00.32 | Name          | Mechanical time constant Tm |      |        | Related mode    | - |
|        | Setting range | 1~65535                     | Unit | 0.01ms | Factory setting | - |

|        |               |              |      |   |                 |   |
|--------|---------------|--------------|------|---|-----------------|---|
| P00.34 | Name          | Encoder type |      |   | Related mode    | - |
|        | Setting range | 0~4          | Unit | - | Factory setting | - |

Set the motor encoder type, please set this parameter correctly, otherwise the driver cannot work normally.

| Set value | Encoder type         |
|-----------|----------------------|
| 0         | Reserved             |
| 1         | Multi-turn absolute  |
| 2         | Single-turn absolute |
| 3         | Reserved             |
| 4         | Reserved             |

|                  |               |                         |      |   |                 |   |
|------------------|---------------|-------------------------|------|---|-----------------|---|
| P00.35<br>P00.36 | Name          | Absolute encoder offset |      |   | Related mode    | - |
|                  | Setting range | 0~1073741824            | Unit | P | Factory setting | 0 |

|        |               |                        |      |     |                 |    |
|--------|---------------|------------------------|------|-----|-----------------|----|
| P00.37 | Name          | Absolute encoder digit |      |     | Related mode    | -  |
|        | Setting range | 10~23                  | Unit | BIT | Factory setting | 17 |

|        |               |                                      |      |     |                 |       |
|--------|---------------|--------------------------------------|------|-----|-----------------|-------|
| P00.38 | Name          | Number of incremental encoder pulses |      |     | Related mode    | -     |
|        | Setting range | 1000~65535                           | Unit | P/r | Factory setting | 10000 |

|        |               |                               |      |   |                 |      |
|--------|---------------|-------------------------------|------|---|-----------------|------|
| P00.39 | Name          | Encoder Z phase signal offset |      |   | Related mode    | -    |
|        | Setting range | 0~65535                       | Unit | P | Factory setting | 1250 |

|        |               |   |      |   |                 |   |
|--------|---------------|---|------|---|-----------------|---|
| P00.40 | Name          | Encoder U phase signal rising edge offset |      |   | Related mode    | - |
|        | Setting range | 0~65535                                   | Unit | P | Factory setting | 0 |

|        |               |  |      |   |                 |   |
|--------|---------------|--|------|---|-----------------|---|
| P00.41 | Name          | Prohibit multi-turn encoder battery fault output |      |   | Related mode    | - |
|        | Setting range | 0~1  | Unit | - | Factory setting | 0 |

|        |               |                                    |      |     |                 |    |
|--------|---------------|------------------------------------|------|-----|-----------------|----|
| P00.42 | Name          | Multi-turn encoder multi-turn bits |      |     | Related mode    | -  |
|        | Setting range | 0~24                               | Unit | Bit | Factory setting | 16 |

|        |               |   |      |   |                 |    |
|--------|---------------|---|------|---|-----------------|----|
| P00.43 | Name          | Driver power-on position calibration torque |      |   | Related mode    | -  |
|        | Setting range | 0~100                                       | Unit | % | Factory setting | 90 |

Refers to the magnitude of the torque when the driver performs position calibration by locking the motor at encoder type P00.34=3/4. The unit is the percentage of rated torque of the motor. This parameter is invalid when P00.34 is set to any other value.

|        |               |   |      |   |                 |   |
|--------|---------------|---|------|---|-----------------|---|
| P00.44 | Name          | Set current position as mechanical zero point |      |   | Related mode    | - |
|        | Setting range | 0~1   | Unit | - | Factory setting | 0 |

In the absolute value system, the mechanical zero point is set by setting P00.44=1. The specific method is: The load moves to the mechanical zero point position through JOG, and then the current position is automatically set as the mechanical zero point by setting the parameter P00.44 as 1.

|                  |               |   |      |   |                 |   |
|------------------|---------------|---|------|---|-----------------|---|
| P00.45<br>P00.46 | Name          | Encoder single-turn value corresponding to the mechanical zero of the absolute value system |      |   | Related mode    | - |
|                  | Setting range | 0~16777216  | Unit | P | Factory setting | 0 |

In the absolute value system, it is used to save the current single-turn value of the motor encoder at the mechanical zero position. After P00.44 is set to 1, the driver will automatically update the current single-turn value of the encoder to P00.45/P00.46.

|                  |               |  |      |      |                 |   |
|------------------|---------------|--|------|------|-----------------|---|
| P00.47<br>P00.48 | Name          | Encoder multi-turn value corresponding to the mechanical zero of the absolute value system |      |      | Related mode    | - |
|                  | Setting range | -16777216~16777216   | Unit | Turn | Factory setting | 0 |

In the absolute value system, it is used to save the current multi-turn value of the motor encoder at the mechanical zero position. After P00.44 is set to 1, the driver will automatically update the current multi-turn value of the encoder to P00.47/P00.48.

|        |               |   |      |   |                 |   |
|--------|---------------|---|------|---|-----------------|---|
| P00.49 | Name          | It is forbidden to use the absolute encoder position to update the current position command |      |   | Related mode    | - |
|        | Setting range | 0~1   | Unit | - | Factory setting | 0 |

Whether it is forbidden to use the absolute encoder value to update the current position command P13.07

|                  |               |                                     |      |   |                 |       |
|------------------|---------------|-------------------------------------|------|---|-----------------|-------|
| P00.50<br>P00.51 | Name          | Divided output gear ratio numerator |      |   | Related mode    | -     |
|                  | Setting range | 1~8388608                           | Unit | - | Factory setting | 10000 |

|                  |               |                                 |      |   |                 |        |
|------------------|---------------|---------------------------------|------|---|-----------------|--------|
| P00.52<br>P00.53 | Name          | Divided output gear denominator |      |   | Related mode    | -      |
|                  | Setting range | 1~8388608                       | Unit | - | Factory setting | 131072 |

|        |               |   |      |   |                 |   |
|--------|---------------|---|------|---|-----------------|---|
| P00.54 | Name          | Exchange frequency division output AB phase pulse |      |   | Related mode    | - |
|        | Setting range | 0~1   | Unit | - | Factory setting | 0 |

|        |               |                               |      |   |                 |   |
|--------|---------------|-------------------------------|------|---|-----------------|---|
| P00.55 | Name          | Encoder EEPROM version number |      |   | Related mode    | - |
|        | Setting range | -                             | Unit | - | Factory setting | - |

|        |               |   |      |   |                 |      |
|--------|---------------|---|------|---|-----------------|------|
| P00.56 | Name          | Rotation mode enable (frequency division output Z-phase signal width) |      |   | Related mode    | -    |
|        | Setting range | 0~1(1~65535)  | Unit | - | Factory setting | 0(8) |

|        |               |   |      |   |                 |   |
|--------|---------------|---|------|---|-----------------|---|
| P00.57 | Name          | Frequency division output Z phase signal polarity |      |   | Related mode    | - |
|        | Setting range | 0~1   | Unit | - | Factory setting | 0 |

|        |               |   |      |   |                 |   |
|--------|---------------|---|------|---|-----------------|---|
| P00.58 | Name          | Frequency division output Z phase initialization mode |      |   | Related mode    | - |
|        | Setting range | 0~1   | Unit | - | Factory setting | 0 |

## 5.2 Group P01: Basic control parameters

|        |               |                        |      |   |                 |   |
|--------|---------------|------------------------|------|---|-----------------|---|
| P01.00 | Name          | Control mode selection |      |   | Related mode    | - |
|        | Setting range | 0~7                    | Unit | - | Factory setting | 0 |

Select the servo driver control mode.

| Set value | Control mode                         |
|-----------|--------------------------------------|
| 0         | Position mode                        |
| 1         | Speed mode                           |
| 2         | Torque mode                          |
| 3         | EtherCAT/CANopen                     |
| 4         | Speed mode-Torque mode               |
| 5         | Position mode-Speed mode             |
| 6         | Position mode-Torque mode            |
| 7         | Position mode-Speed mode-Torque mode |

|        |               |                              |      |   |                 |   |
|--------|---------------|------------------------------|------|---|-----------------|---|
| P01.01 | Name          | Rotation direction selection |      |   | Related mode    | - |
|        | Setting range | 0~1                          | Unit | - | Factory setting | 0 |

Set the forward direction of motor rotation when observed from the motor output shaft.

| Set value | Direction of rotation                           | Remark  |
|-----------|---|---|
| 0         | Take the CCW direction as the forward direction | In the case of a forward command, from the side of the motor shaft, the motor rotation direction is the CCW direction, that is, the motor rotates counterclockwise. |
| 1         | Take the CW direction as the forward direction  | In the case of a positive command, from the side of the motor shaft, the motor rotation direction is the CW direction, that is, the motor rotates clockwise.        |

|        |      |  |         |         |
|--------|------|--|---------|---------|
| P01.20 | Name | The minimum value of braking resistance allowed by the | Related | display |
|--------|------|--|---------|---------|

|  |               |        |      |          |                 |   |
|--|---------------|--------|------|----------|-----------------|---|
|  |               | driver |      |          | mode            |   |
|  | Setting range | -      | Unit | $\Omega$ | Factory setting | - |
| Check the minimum value of braking resistance allowed by a certain model of driver, which is only related to the driver model. |               |        |      |          |                 |   |

|  |               |                                   |      |   |                 |         |
|--|---------------|-----------------------------------|------|---|-----------------|---------|
| P01.21   | Name          | Built-in braking resistance power |      |   | Related mode    | display |
|  | Setting range | -                                 | Unit | W | Factory setting | -       |
| Check the built-in braking resistor power of a certain type of driver, it cannot be changed, it is only related to the servo driver model. |               |                                   |      |   |                 |         |

|  |               |                                   |      |          |                 |         |
|--|---------------|-----------------------------------|------|----------|-----------------|---------|
| P01.22   | Name          | Built-in braking resistance value |      |          | Related mode    | display |
|  | Setting range | -                                 | Unit | $\Omega$ | Factory setting | -       |
| Check the minimum value of braking resistance allowed by a certain model of driver, which is only related to the driver model. |               |                                   |      |          |                 |         |

|  |               |   |      |   |                 |    |
|--|---------------|---|------|---|-----------------|----|
| P01.23   | Name          | Resistance heat dissipation coefficient |      |   | Related mode    | -  |
|  | Setting range | 1~100                                   | Unit | - | Factory setting | 20 |
| When setting and using a braking resistor, the heat dissipation coefficient of the resistor is valid for both built-in and external braking resistors. Please set this parameter according to the actual heat dissipation conditions of the resistor. Recommended value: generally, when natural cooling, P01.23 does not exceed 30%; when forced air cooling, P01.23 does not exceed 50%. |               |   |      |   |                 |    |

|        |               |  |      |   |                 |         |
|--------|---------------|--|------|---|-----------------|---------|
| P01.24 | Name          | Braking resistance setting   |      |   | Related mode    | display |
|        | Setting range | 0: Use built-in braking resistor<br>1: Use external braking resistor | Unit | - | Factory setting | 0       |

|        |               |                                   |      |   |                 |    |
|--------|---------------|-----------------------------------|------|---|-----------------|----|
| P01.25 | Name          | External braking resistance power |      |   | Related mode    | -  |
|        | Setting range | 1~65535                           | Unit | W | Factory setting | 50 |

|        |               |                                   |      |          |                 |    |
|--------|---------------|-----------------------------------|------|----------|-----------------|----|
| P01.26 | Name          | External braking resistance value |      |          | Related mode    | -  |
|        | Setting range | 1~1000                            | Unit | $\Omega$ | Factory setting | 10 |

|        |               |                             |      |   |                 |    |
|--------|---------------|-----------------------------|------|---|-----------------|----|
| P01.27 | Name          | Braking start voltage value |      |   | Related mode    | -  |
|        | Setting range | 1~100                       | Unit | V | Factory setting | 68 |

|        |               |  |      |   |                 |   |
|--------|---------------|--|------|---|-----------------|---|
| P01.28 | Name          | Brake feedback detection mode (Do not set) |      |   | Related mode    | - |
|        | Setting range | 0~1(Do not set)                            | Unit | V | Factory setting | 1 |

|        |               |                                 |      |    |                 |      |
|--------|---------------|---------------------------------|------|----|-----------------|------|
| P01.29 | Name          | Maximum continuous braking time |      |    | Related mode    | -    |
|        | Setting range | 0~65535                         | Unit | ms | Factory setting | 3000 |

|        |               |   |      |    |                 |   |
|--------|---------------|---|------|----|-----------------|---|
| P01.33 | Name          | Emergency stop deceleration time constant |      |    | Related mode    | - |
|        | Setting range | 1~65535                                   | Unit | ms | Factory setting | 5 |

Set the time for the speed to change uniformly from 1000rpm to 0rpm when the motor stops suddenly.

|        |               |                             |      |    |                 |    |
|--------|---------------|-----------------------------|------|----|-----------------|----|
| P01.36 | Name          | Servo enable delay off time |      |    | Related mode    | -  |
|        | Setting range | 0~65535                     | Unit | ms | Factory setting | 50 |

Set the delay time for the servo drive to change from "enable" to "disable" when the servo drive's enable signal changes from "valid" to "invalid".

|        |               |   |      |      |                 |     |
|--------|---------------|---|------|------|-----------------|-----|
| P01.37 | Name          | Speed regulator saturation detection time |      |      | Related mode    | -   |
|        | Setting range | 0~65535                                   | Unit | 10ms | Factory setting | 450 |

When the continuous saturation time of the internal speed regulator in the system exceeds this set value, a speed regulator saturation alarm will be generated. It is used to prevent excessive continuous current caused by mechanical jamming or other reasons.

- Note: When the set value is 0, the speed regulator saturation detection fault alarm is prohibited.

|        |               |  |      |    |                 |     |
|--------|---------------|--|------|----|-----------------|-----|
| P01.42 | Name          | Command overload initial detection point |      |    | Related mode    | -   |
|        | Setting range | 0~300                                    | Unit | 1% | Factory setting | 100 |

Set the initial torque point for command overload protection of the servo driver. The set value is the percentage of the rated current of the servo motor. When the current torque of the servo motor is higher than this value, the system's internal command overload counter counts the command overload. After the count value exceeds, the servo drive will output a command overload alarm.

- Note: When the parameter P01.42 is greater than the parameter P01.43, the command overload protection



detection function will be prohibited.

|        |               |                                       |      |    |                 |     |
|--------|---------------|---------------------------------------|------|----|-----------------|-----|
| P01.43 | Name          | Command overload peak detection point |      |    | Related mode    | -   |
|        | Setting range | 0~300                                 | Unit | 1% | Factory setting | 300 |

Set the peak torque point for command overload protection of the servo driver. The set value is the percentage of the rated current of the servo motor. Together with P01.42 and P01.44, it composes the command overload protection feature of the servo driver.

- Note: When the parameter P01.42 is greater than the parameter P01.43, the command overload protection detection function will be prohibited.

|        |               |                                 |      |      |                 |     |
|--------|---------------|---------------------------------|------|------|-----------------|-----|
| P01.44 | Name          | Command overload detection time |      |      | Related mode    | -   |
|        | Setting range | 0~65535                         | Unit | 10ms | Factory setting | 450 |

Set the command overload protection detection time, which is set based on the motor overload characteristic parameters.

|        |               |  |      |    |                 |     |
|--------|---------------|--|------|----|-----------------|-----|
| P01.45 | Name          | Thermal overload initial detection point |      |    | Related mode    | -   |
|        | Setting range | 0~300                                    | Unit | 1% | Factory setting | 100 |

Set the initial torque point for thermal overload protection of the servo driver. The thermal overload protection of the servo driver uses the method of  $I^2t$  to calculate. The set value is the percentage of the rated current of the servo motor.

- Note: When the parameter P01.45 is greater than the parameter P01.46, the thermal overload protection detection function will be prohibited.

|        |               |                                       |      |    |                 |     |
|--------|---------------|---------------------------------------|------|----|-----------------|-----|
| P01.46 | Name          | Thermal overload peak detection point |      |    | Related mode    | -   |
|        | Setting range | 0~300                                 | Unit | 1% | Factory setting | 300 |

Set the peak torque point for thermal overload protection of the servo driver. The set value is the percentage of the rated current of the servo motor. Together with P01.45 and P01.47, it composes the thermal overload protection characteristics of the servo driver.

- Note: When the parameter P01.45 is greater than the parameter P01.46, the thermal overload protection detection function will be prohibited.

|        |               |                                 |      |      |                 |     |
|--------|---------------|---------------------------------|------|------|-----------------|-----|
| P01.47 | Name          | Thermal overload detection time |      |      | Related mode    | -   |
|        | Setting range | 0~65535                         | Unit | 10ms | Factory setting | 450 |

Set the command overload protection detection time, which is set based on the motor thermal overload characteristic parameters.

|        |               |                                 |      |   |                 |    |
|--------|---------------|---------------------------------|------|---|-----------------|----|
| P01.48 | Name          | Overvoltage detection threshold |      |   | Related mode    | -  |
|        | Setting range | 1~100                           | Unit | V | Factory setting | 85 |

|        |               |                                  |      |   |                 |    |
|--------|---------------|----------------------------------|------|---|-----------------|----|
| P01.49 | Name          | Undervoltage detection threshold |      |   | Related mode    | -  |
|        | Setting range | 1~100                            | Unit | V | Factory setting | 15 |

### 5.3 Group P02: Terminal input/output parameters

|        |               |                                 |      |   |                 |   |
|--------|---------------|---------------------------------|------|---|-----------------|---|
| P02.00 | Name          | IN1 terminal function selection |      |   | Related mode    | - |
|        | Setting range | 0~31                            | Unit | - | Factory setting | 1 |

Set the IN function corresponding to the hardware IN1 terminal. Please refer to the following table for parameter

| Set value | IN terminal function                                  | Set value | IN terminal function                                  |
|-----------|---|-----------|---|
| 0         | FunIN.0: Normal input                                 | 16        | FunIN.16: Multi-segment operation command switching 3 |
| 1         | FunIN.1: Servo enable                                 | 17        | FunIN.17: Multi-segment operation command switching 4 |
| 2         | FunIN.2: Alarm clear                                  | 18        | FunIN.18: Torque command direction setting            |
| 3         | FunIN.3: Pulse command prohibition                    | 19        | FunIN.19: Speed command direction setting             |
| 4         | FunIN.4: Clear position deviation                     | 20        | FunIN.20: Position command direction setting          |
| 5         | FunIN.5: Positive limit signal                        | 21        | FunIN.21: Multi-segment position command enable       |
| 6         | FunIN.6: Negative limit signal                        | 22        | FunIN.22: Return to origin input                      |
| 7         | FunIN.7: Gain switching                               | 23        | FunIN.23: Origin switch signal                        |
| 8         | FunIN.8: Electronic gear ratio switch                 | 24        | FunIN.24: USER1                                       |
| 9         | FunIN.9: Zero-speed clamp                             | 25        | FunIN.25: USER2                                       |
| 10        | FunIN.10: Control mode selection 1                    | 26        | FunIN.26: USER3                                       |
| 11        | FunIN.11: Emergency stop                              | 27        | FunIN.27: USER4                                       |
| 12        | FunIN.12: Position command prohibition                | 28        | FunIN.28: USER5                                       |
| 13        | FunIN.13: Step position trigger                       | 29        | FunIN.29: Control mode selection 2                    |
| 14        | FunIN.14: Multi-segment operation command switching 1 | 30        | FunIN.30: Probe 1                                     |
| 15        | FunIN.15: Multi-segment operation command switching 2 | 31        | FunIN.31: Probe 2                                     |

setting:

|  |  |  |  |  |  |
|--|--|--|--|--|--|
|  |  |  |  |  |  |
|--|--|--|--|--|--|

|        |               |                              |      |   |                 |   |
|--------|---------------|------------------------------|------|---|-----------------|---|
| P02.01 | Name          | IN1 terminal logic selection |      |   | Related mode    | - |
|        | Setting range | 0~1                          | Unit | - | Factory setting | 0 |

Set the level logic of the hardware IN1 terminal when the IN function selected by IN1 is valid. Please set the effective level logic correctly according to the host computer and peripheral circuit.

| Set value | IN terminal logic when IN function is valid |
|-----------|---|
| 0         | Low level                                   |
| 1         | High level                                  |

|        |               |                                 |      |   |                 |   |
|--------|---------------|---------------------------------|------|---|-----------------|---|
| P02.02 | Name          | IN2 terminal function selection |      |   | Related mode    | - |
|        | Setting range | 0~31                            | Unit | - | Factory setting | 5 |

|        |               |                              |      |   |                 |   |
|--------|---------------|------------------------------|------|---|-----------------|---|
| P02.03 | Name          | IN2 terminal logic selection |      |   | Related mode    | - |
|        | Setting range | 0~1                          | Unit | - | Factory setting | 0 |

|        |               |                                 |      |   |                 |   |
|--------|---------------|---------------------------------|------|---|-----------------|---|
| P02.04 | Name          | IN3 terminal function selection |      |   | Related mode    | - |
|        | Setting range | 0~31                            | Unit | - | Factory setting | 6 |

|        |               |                              |      |   |                 |   |
|--------|---------------|------------------------------|------|---|-----------------|---|
| P02.05 | Name          | IN3 terminal logic selection |      |   | Related mode    | - |
|        | Setting range | 0~1                          | Unit | - | Factory setting | 0 |

|        |               |                                 |      |   |                 |    |
|--------|---------------|---------------------------------|------|---|-----------------|----|
| P02.06 | Name          | IN4 terminal function selection |      |   | Related mode    | -  |
|        | Setting range | 0~31                            | Unit | - | Factory setting | 23 |

|        |               |                              |      |   |                 |   |
|--------|---------------|------------------------------|------|---|-----------------|---|
| P02.07 | Name          | IN4 terminal logic selection |      |   | Related mode    | - |
|        | Setting range | 0~1                          | Unit | - | Factory setting | 0 |

|        |               |                                 |      |   |                 |   |
|--------|---------------|---------------------------------|------|---|-----------------|---|
| P02.08 | Name          | IN5 terminal function selection |      |   | Related mode    | - |
|        | Setting range | 0~31                            | Unit | - | Factory setting | 0 |

|        |               |                              |      |   |                 |   |
|--------|---------------|------------------------------|------|---|-----------------|---|
| P02.09 | Name          | IN5 terminal logic selection |      |   | Related mode    | - |
|        | Setting range | 0~1                          | Unit | - | Factory setting | 0 |

|        |               |                                 |      |   |                 |   |
|--------|---------------|---------------------------------|------|---|-----------------|---|
| P02.10 | Name          | IN6 terminal function selection |      |   | Related mode    | - |
|        | Setting range | 0~31                            | Unit | - | Factory setting | 0 |

|        |               |                              |      |   |                 |   |
|--------|---------------|------------------------------|------|---|-----------------|---|
| P02.11 | Name          | IN6 terminal logic selection |      |   | Related mode    | - |
|        | Setting range | 0~1                          | Unit | - | Factory setting | 0 |

|        |               |                                 |      |   |                 |   |
|--------|---------------|---------------------------------|------|---|-----------------|---|
| P02.12 | Name          | IN7 terminal function selection |      |   | Related mode    | - |
|        | Setting range | 0~31                            | Unit | - | Factory setting | 0 |

|        |               |                              |      |   |                 |   |
|--------|---------------|------------------------------|------|---|-----------------|---|
| P02.13 | Name          | IN7 terminal logic selection |      |   | Related mode    | - |
|        | Setting range | 0~1                          | Unit | - | Factory setting | 0 |

|        |               |                                 |      |   |                 |   |
|--------|---------------|---------------------------------|------|---|-----------------|---|
| P02.14 | Name          | IN8 terminal function selection |      |   | Related mode    | - |
|        | Setting range | 0~31                            | Unit | - | Factory setting | 0 |

|        |               |                              |      |   |                 |   |
|--------|---------------|------------------------------|------|---|-----------------|---|
| P02.15 | Name          | IN8 terminal logic selection |      |   | Related mode    | - |
|        | Setting range | 0~1                          | Unit | - | Factory setting | 0 |

|        |               |                                 |      |   |                 |   |
|--------|---------------|---------------------------------|------|---|-----------------|---|
| P02.16 | Name          | IN9 terminal function selection |      |   | Related mode    | - |
|        | Setting range | 0~31                            | Unit | - | Factory setting | 0 |

|        |               |                              |      |   |                 |   |
|--------|---------------|------------------------------|------|---|-----------------|---|
| P02.17 | Name          | IN9 terminal logic selection |      |   | Related mode    | - |
|        | Setting range | 0~1                          | Unit | - | Factory setting | 0 |

|        |               |                                  |      |   |                 |   |
|--------|---------------|----------------------------------|------|---|-----------------|---|
| P02.32 | Name          | OUT1 terminal function selection |      |   | Related mode    | - |
|        | Setting range | 0~31                             | Unit | - | Factory setting | 1 |

Set the OUT function corresponding to the OUT1 terminal. Refer to the following table for parameter Settings.

| Set value | OUT terminal function                    | Set value | OUT terminal function              |
|-----------|--|-----------|------------------------------------|
| 0         | FunOUT.0: Brake                          | 9         | FunOUT.9: USER3                    |
| 1         | FunOUT.1: Alarm                          | 10        | FunOUT.10: USER4                   |
| 2         | FunOUT.2: Position reached               | 11        | FunOUT.11: USER5                   |
| 3         | FunOUT.3: Speed reached                  | 12        | FunOUT.12: USER6                   |
| 4         | FunOUT.4: Servo ready                    | 13        | FunOUT.13: Torque reached          |
| 5         | FunOUT.5: Internal position command stop | 14        | FunOUT.14: Out-of-tolerance output |
| 6         | FunOUT.6: Return to origin completed     | 15~30     | Reserve                            |
| 7         | FunOUT.7: USER1                          | 31        | Universal output                   |
| 8         | FunOUT.8: USER2                          |           |                                    |

|        |               |                               |      |   |                 |   |
|--------|---------------|-------------------------------|------|---|-----------------|---|
| P02.33 | Name          | OUT1 terminal logic selection |      |   | Related mode    | - |
|        | Setting range | 0~1                           | Unit | - | Factory setting | 0 |

Set the output level logic of the hardware OUT1 terminal when the OUT function selected by OUT1 is valid.

| Set value | OUT1 terminal logic when the OUT function is valid | Transistor state |
|-----------|--|------------------|
| 0         | Low level  | Conduction       |
| 1         | High level   | Shut off         |

|        |               |                                  |      |   |                 |   |
|--------|---------------|----------------------------------|------|---|-----------------|---|
| P02.34 | Name          | OUT2 terminal function selection |      |   | Related mode    | - |
|        | Setting range | 0~31                             | Unit | - | Factory setting | 6 |

|        |               |                               |      |   |                 |   |
|--------|---------------|-------------------------------|------|---|-----------------|---|
| P02.35 | Name          | OUT2 terminal logic selection |      |   | Related mode    | - |
|        | Setting range | 0~1                           | Unit | - | Factory setting | 0 |

|        |               |                                  |      |   |                 |   |
|--------|---------------|----------------------------------|------|---|-----------------|---|
| P02.36 | Name          | OUT3 terminal function selection |      |   | Related mode    | - |
|        | Setting range | 0~31                             | Unit | - | Factory setting | 0 |

|        |               |                               |      |   |                 |   |
|--------|---------------|-------------------------------|------|---|-----------------|---|
| P02.37 | Name          | OUT3 terminal logic selection |      |   | Related mode    | - |
|        | Setting range | 0~1                           | Unit | - | Factory setting | 0 |

|        |               |                              |      |   |                 |   |
|--------|---------------|------------------------------|------|---|-----------------|---|
| P02.52 | Name          | IN terminal forced effective |      |   | Related mode    | - |
|        | Setting range | 0~65535                      | Unit | - | Factory setting | 0 |

Set the FunIN function corresponding to the IN terminal to be forcibly valid. If the corresponding bit is set to 1, the FunIN function corresponding to the IN terminal is forcibly valid. Set to 0, no effect. As follows:

| BIT  | Corresponding IN terminal |
|------|---------------------------|
| 7~15 | Reserve                   |
| 8    | IN9                       |
| 7    | IN8                       |
| 6    | IN7                       |
| 5    | IN6                       |
| 4    | IN5                       |
| 3    | IN4                       |
| 2    | IN3                       |
| 1    | IN2                       |
| 0    | IN1                       |

|        |               |                               |      |   |                 |   |
|--------|---------------|-------------------------------|------|---|-----------------|---|
| P02.53 | Name          | OUT terminal forced effective |      |   | Related mode    | - |
|        | Setting range | 0~65535                       | Unit | - | Factory setting | 0 |

Setting OUT terminal output to be forcibly valid. If the corresponding bit is set to 1, the OUT terminal is forcibly valid. Set to 0, no effect. As follows:

| BIT  | Corresponding OUT terminal |
|------|----------------------------|
| 3~15 | Reserve                    |
| 2    | OUT3                       |
| 1    | OUT2                       |
| 0    | OUT1                       |

|                  |               |                           |      |   |                 |    |
|------------------|---------------|---------------------------|------|---|-----------------|----|
| P02.54<br>P02.55 | Name          | FunIN function valid flag |      |   | Related mode    | -  |
|                  | Setting range | -                         | Unit | - | Factory setting | 显示 |

Displays the effectiveness of the FunIN function of the current driver. The value "1" indicates that the FunIN function is valid, and the value "0" indicates that the FunIN function is invalid.

| BIT | Description   | BIT | Description   |
|-----|---|-----|---|
| 0   | FunIN.0: Normal input                                 | 16  | FunIN.16: Multi-segment operation command switching 3 |
| 1   | FunIN.1: Servo enable                                 | 17  | FunIN.17: Multi-segment operation command switching 4 |
| 2   | FunIN.2: Alarm clear                                  | 18  | FunIN.18: Torque command direction setting            |
| 3   | FunIN.3: Pulse command prohibition                    | 19  | FunIN.19: Speed command direction setting             |
| 4   | FunIN.4: Clear position deviation                     | 20  | FunIN.20: Position command direction setting          |
| 5   | FunIN.5: Positive limit signal                        | 21  | FunIN.21: Multi-segment position command enable       |
| 6   | FunIN.6: Negative limit signal                        | 22  | FunIN.22: Return to origin input                      |
| 7   | FunIN.7: Gain switching                               | 23  | FunIN.23: Origin switch signal                        |
| 8   | FunIN.8: Electronic gear ratio switch                 | 24  | FunIN.24: USER1                                       |
| 9   | FunIN.9: Zero-speed clamp                             | 25  | FunIN.25: USER2                                       |
| 10  | FunIN.10: Control mode selection 1                    | 26  | FunIN.26: USER3                                       |
| 11  | FunIN.11: Emergency stop                              | 27  | FunIN.27: USER4                                       |
| 12  | FunIN.12: Position command prohibition                | 28  | FunIN.28: USER5                                       |
| 13  | FunIN.13: Step position trigger                       | 29  | FunIN.29: Control mode selection 2                    |
| 14  | FunIN.14: Multi-segment operation command switching 1 | 30  | FunIN.30: Probe 1                                     |
| 15  | FunIN.15: Multi-segment operation command switching 2 | 31  | FunIN.31: Probe 2                                     |

|                  |               |  |      |   |                 |   |
|------------------|---------------|--|------|---|-----------------|---|
| P02.56<br>P02.57 | Name          | The rising edge of the FunIN function latches the valid flag |      |   | Related mode    | - |
|                  | Setting range | 0~65535  | Unit | - | Factory setting | - |

Shows the effectiveness of the input function's rising edge latch since the FunIN function of the current driver was cleared last time. The corresponding BIT bit field value is "1", which means that the FunIN function has detected the rising edge state, and the corresponding BIT bit field value is "0" means that the FunIN function has not detected the rising edge state.

Write the value "1" to the corresponding BIT field of this parameter to clear the latch flag.

FunIN corresponds to the parameter BIT bit field, please refer to parameter P02.54/P02.55

|                  |               |   |      |   |                 |   |
|------------------|---------------|---|------|---|-----------------|---|
| P02.58<br>P02.59 | Name          | The falling edge of the FunIN function latches the valid flag |      |   | Related mode    | - |
|                  | Setting range | 0~65535   | Unit | - | Factory setting | - |

Shows the effectiveness of the input function's falling edge latch since the FunIN function of the current driver was cleared last time. The corresponding BIT bit field value is "1", which means that the FunIN function has detected the falling edge state, and the corresponding BIT bit field value is "0" means that the FunIN function has not detected the falling edge state.

Write the value "1" to the corresponding BIT field of this parameter to clear the latch flag.

FunIN corresponds to the parameter BIT bit field, please refer to parameter P02.54/P02.55

|                  |               |                            |      |   |                 |    |
|------------------|---------------|----------------------------|------|---|-----------------|----|
| P02.60<br>P02.61 | Name          | FunOUT function valid flag |      |   | Related mode    | -  |
|                  | Setting range | -                          | Unit | - | Factory setting | 显示 |

Display the effectiveness of the FunOUT function of the current driver. The value "1" indicates that the FunOUT function is valid, and the value "0" indicates that the FunOUT function is invalid.

| Set value | Description                              | Set value | Description                        |
|-----------|--|-----------|------------------------------------|
| 0         | FunOUT.0: Brake                          | 9         | FunOUT.9: USER3                    |
| 1         | FunOUT.1: Alarm                          | 10        | FunOUT.10: USER4                   |
| 2         | FunOUT.2: Position reached               | 11        | FunOUT.11: USER5                   |
| 3         | FunOUT.3: Speed reached                  | 12        | FunOUT.12: USER6                   |
| 4         | FunOUT.4: Servo ready                    | 13        | FunOUT.13: Torque reached          |
| 5         | FunOUT.5: Internal position command stop | 14        | FunOUT.14: Out-of-tolerance output |
| 6         | FunOUT.6: Return to origin completed     | 15~30     | Reserve                            |
| 7         | FunOUT.7: USER1                          | 31        | Universal output                   |
| 8         | FunOUT.8: USER2                          |           |                                    |

|        |               |                        |      |   |                 |   |
|--------|---------------|------------------------|------|---|-----------------|---|
| P02.62 | Name          | Physical output enable |      |   | Related mode    | - |
|        | Setting range | 0~65535                | Unit | - | Factory setting | 0 |

When the output function of the OUT port is set to "FunOUT.31 general output", the output status of the OUT port of the servo driver can be controlled by operating the P02.62 and P02.63 parameters.

| BIT  | Set value | Corresponding to IN terminal                            |
|------|-----------|---|
| 3~15 | -         | Reserve   |
| 2    | 0         | 0: OUT3 output port is not controlled by BIT2 of P02.63 |
|      | 1         | 1: OUT3 output port is controlled by BIT2 of P02.63     |
| 1    | 0         | 0: OUT2 output port is not controlled by BIT1 of P02.63 |
|      | 1         | 1: OUT2 output port is controlled by BIT1 of P02.63     |
| 0    | 0         | 0: OUT1 output port is not controlled by BIT0 of P02.63 |
|      | 1         | 1: OUT1 output port is controlled by BIT0 of P02.63     |

|        |               |                        |      |   |                 |   |
|--------|---------------|------------------------|------|---|-----------------|---|
| P02.63 | Name          | Physical output status |      |   | Related mode    | - |
|        | Setting range | 0~65535                | Unit | - | Factory setting | 0 |



When the output function of the OUT port is set to "FunOUT.31 general output", the output status of the OUT port of the servo driver can be controlled by operating the P02.62 and P02.63 parameters. Only when the corresponding bit field of the P02.62 parameter is set to "1" (enable), the OUT port of the servo driver is controlled by the P02.63 parameter.

| BIT  | Set value | Corresponding to IN terminal           |
|------|-----------|--|
| 3~15 | -         | Reserve                                |
| 2    | 0         | 0: OUT3 output port optocoupler is off |
|      | 1         | 1: OUT3 output port optocoupler is on  |
| 1    | 0         | 0: OUT2 output port optocoupler is off |
|      | 1         | 1: OUT2 output port optocoupler is on  |
| 0    | 0         | 0: OUT1 output port optocoupler is off |
|      | 1         | 1: OUT1 output port optocoupler is on  |

### 5.4 Group P03: Position control parameters



|        |               |                         |      |   |                 |   |
|--------|---------------|-------------------------|------|---|-----------------|---|
| P03.00 | Name          | Position command source |      |   | Related mode    | - |
|        | Setting range | 0~10                    | Unit | - | Factory setting | 0 |

In position control mode, it is used to select the source of position command. Among them, the pulse command belongs to the external position command, and the step operation, the multi-segment position command, and the internal test position command belong to the internal position command.

| Set value | Command source                 | Command acquisition method   |
|-----------|--------------------------------|--|
| 0         | Pulse command                  | The host computer or other pulse generating devices generate position commands and input them to the servo drive through hardware terminals.                     |
| 1         | Step                           | The step displacement is set by the parameter P03.28/P03.29, and the step operation is triggered by the IN function FunIN.13.                                    |
| 2         | Multi-segment position command | The multi-segment position operation mode is set by the P09 group parameters, and the multi-segment position operation is triggered by the IN function FunIN.21. |
| 3         | Communication control          | Communication given position, speed and other parameters as well as start and stop command.  |
| 4         | Communication control 2        | Communication given position, and trajectory can be modified dynamically.  |
| 5         | IO control                     | Control the jog forward and reverse rotation and fixed length forward and reverse rotation in the motor position mode through the IN input.                      |
| 5~10      | -                              | Reserve command source, do not set.  |

|        |               |                    |      |   |                 |   |
|--------|---------------|--------------------|------|---|-----------------|---|
| P03.02 | Name          | Pulse command type |      |   | Related mode    | - |
|        | Setting range | 0~3                | Unit | - | Factory setting | 0 |

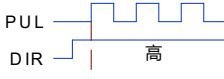
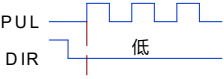
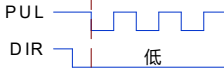
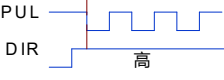
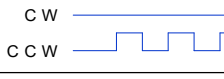
When setting the position command source as pulse command (P03.00=0), input the pulse form.

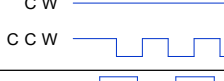
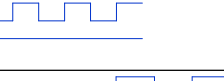
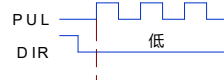
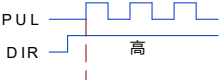
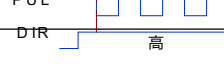
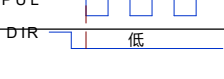
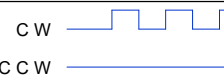
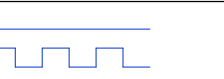
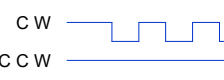
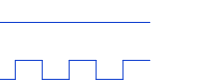
| P01.01<br>Rotation<br>direction<br>selection | P03.02<br>Command<br>type<br>setting                                | Command type                           | Signal                      | Schematic diagram of<br>forward pulse  | Schematic diagram of<br>reverse pulse   |   |
|--|---|--|-----------------------------|--|---|---|
| 0  | 0   | Pulse +<br>direction<br>Positive logic | PUL<br>DIR                  |    |    |   |
|  | 1   | Pulse +<br>direction<br>Negative logic | PUL<br>DIR                  |    |    |   |
|  | 2   | CW+CCW                                 | PUL(CW)<br>DIR(CCW)         | CW<br>CCW  |     |    |
|  |   |  |                             | CW<br>CCW  |     |    |
| 3  | A phase + B<br>phase<br>Quadrature<br>pulse<br>4 times<br>frequency | PUL<br>(A phase)<br>DIR<br>(B phase)   | A相<br>B相<br>A相超前B相90°       | A相<br>B相<br>B相超前A相90°  |   |   |
| 1  | 0   | Pulse +<br>direction<br>Positive logic | PUL<br>DIR                  |  |  |   |
|  | 1   | Pulse +<br>direction<br>Negative logic | PUL<br>DIR                  |  |  |   |
|  | 2   | CW+CCW                                 | PUL<br>(CW)<br>DIR<br>(CCW) | CW<br>CCW  |   |  |
|  |   |  |                             | CW<br>CCW  |   |  |
| 3  | A phase + B<br>phase<br>Quadrature<br>pulse<br>4 times<br>frequency | PUL<br>(A phase)<br>DIR<br>(B phase)   | A相<br>B相<br>B相超前A相90°       | A相<br>B相<br>A相超前B相90°  |   |   |

|        |               |   |      |       |                 |   |
|--------|---------------|---|------|-------|-----------------|---|
| P03.04 | Name          | Position command average filter time constant |      |       | Related mode    | - |
|        | Setting range | 1~2048  | Unit | 0.1ms | Factory setting | 1 |

Set the average filter time constant of the position command (encoder unit). This function has no effect on the total

number of position commands. If the set value is too large, the response delay will increase. The filter time constant should be set according to the actual situation.

|        |               |  |      |       |                 |   |
|--------|---------------|--|------|-------|-----------------|---|
| P03.05 | Name          | Position command first-order low-pass filter time constant |      |       | Related mode    | - |
|        | Setting range | 0~65535  | Unit | 0.1ms | Factory setting | 0 |

Set the first-order low-pass filter time constant of the position command (encoder unit). This function has no effect on the total number of position commands. If the set value is too large, the response delay will increase. The filter time constant should be set according to the actual situation.

|                  |               |  |      |     |                 |       |
|------------------|---------------|--|------|-----|-----------------|-------|
| P03.06<br>P03.07 | Name          | Number of position commands for one motor rotation |      |     | Related mode    | -     |
|                  | Setting range | 0~8388608  | Unit | P/r | Factory setting | 10000 |

Set the number of position commands required for the motor to not rotate one revolution. P03.06 and P03.07 are combined into a 32-bit value, where P03.06 is the low 16-bit value, and P03.07 is the high 16-bit value. Subsequent use P03.06 to represent the 32-bit parameter.  
 When P03.06=0, the parameters of electronic gear ratio 1 and 2 (P03.08~P03.15) are valid.  
 When P03.06≠0, electronic gear ratio B/A=encoder resolution/P03.06, at this time, electronic gear ratio 1 and electronic gear ratio 2 are invalid.

|                  |               |                                   |      |   |                 |   |
|------------------|---------------|-----------------------------------|------|---|-----------------|---|
| P03.08<br>P03.09 | Name          | Electronic gear ratio numerator 1 |      |   | Related mode    | P |
|                  | Setting range | 1~1073741824                      | Unit | - | Factory setting | 1 |

Set the first group of electronic gear ratio numerator for position command (command unit) frequency division. P03.08 and P03.09 are combined into a 32-bit value, where P03.08 is the low 16-bit value, and P03.09 is the high 16-bit value. Subsequent use P03.08 to represent the 32-bit parameter.  
 P03.06 (number of position command pulses per motor rotation)=0 is valid.

|                  |               |                                     |      |   |                 |   |
|------------------|---------------|-------------------------------------|------|---|-----------------|---|
| P03.10<br>P03.11 | Name          | Electronic gear ratio denominator 1 |      |   | Related mode    | P |
|                  | Setting range | 1~1073741824                        | Unit | - | Factory setting | 1 |

Set the first group of electronic gear ratio denominator for position command (command unit) frequency division. P03.10 and P03.11 are combined into a 32-bit value, where P03.10 is the low 16-bit value, and P03.11 is the high 16-bit value. Subsequent use P03.10 to represent the 32-bit parameter.  
 P03.06 (number of position command pulses per motor rotation)=0 is valid.

|                  |               |                                   |      |   |                 |   |
|------------------|---------------|-----------------------------------|------|---|-----------------|---|
| P03.12<br>P03.13 | Name          | Electronic gear ratio numerator 2 |      |   | Related mode    | P |
|                  | Setting range | 1~1073741824                      | Unit | - | Factory setting | 1 |

Set the second group of electronic gear ratio numerator for position command (command unit) frequency division. P03.12 and P03.13 are combined into a 32-bit value, where P03.12 is the low 16-bit value, and P03.13 is the high 16-bit value. Subsequent use P03.12 to represent the 32-bit parameter.

P03.06 (number of position command pulses per motor rotation)=0 is valid.

|                  |               |                                     |      |   |                 |   |
|------------------|---------------|-------------------------------------|------|---|-----------------|---|
| P03.14<br>P03.15 | Name          | Electronic gear ratio denominator 2 |      |   | Related mode    | P |
|                  | Setting range | 1~1073741824                        | Unit | - | Factory setting | 1 |

Set the second group of electronic gear ratio denominator for position command(command unit) frequency division. P03.14 and P03.15 are combined into a 32-bit value, where P03.14 is the low 16-bit value, and P03.15 is the high 16-bit value. Subsequent use P03.14 to represent the 32-bit parameter.

P03.06 (number of position command pulses per motor rotation) = 0, valid

|        |               |                                       |      |       |                 |    |
|--------|---------------|---------------------------------------|------|-------|-----------------|----|
| P03.20 | Name          | In-position signal establishment time |      |       | Related mode    | P  |
|        | Setting range | 0~65535                               | Unit | 0.1ms | Factory setting | 10 |

It is used to set the establishment time for the in-position signal output to change from invalid to valid state. After the driver has passed the delay time set by P03.21, if the position command error is less than the setting value of positioning accuracy P03.22, and the time set by P03.20 is maintained, the driver will output an in-position completion signal.

|        |               |                                      |      |       |                 |    |
|--------|---------------|--------------------------------------|------|-------|-----------------|----|
| P03.21 | Name          | Position command stop detection time |      |       | Related mode    | P  |
|        | Setting range | 0~65535                              | Unit | 0.1ms | Factory setting | 10 |

It is used to set the detection time when the position command stops. After the driver detects that the position command is stopped, and after the set time has elapsed, the output logic of the in-position signal is processed.

|        |               |                                  |      |              |                 |    |
|--------|---------------|----------------------------------|------|--------------|-----------------|----|
| P03.22 | Name          | Positioning completion threshold |      |              | Related mode    | P  |
|        | Setting range | 1~65535                          | Unit | Encoder unit | Factory setting | 10 |

Set the threshold of the absolute value of the position deviation when the servo driver outputs the positioning completion signal.

|        |               |   |      |   |                 |   |
|--------|---------------|---|------|---|-----------------|---|
| P03.23 | Name          | Clear position deviation action selection |      |   | Related mode    | P |
|        | Setting range | 0~1                                       | Unit | - | Factory setting | 0 |

Set the clear mode of position deviation when servo enable is OFF.

| Set value | Clear position deviation mode                     |
|-----------|---|
| 0         | Servo enable OFF, clear position deviation        |
| 1         | Servo enable OFF, do not clear position deviation |

|        |      |   |  |  |         |   |
|--------|------|---|--|--|---------|---|
| P03.24 | Name | Position deviation fault detection prohibited |  |  | Related | P |
|--------|------|---|--|--|---------|---|

|  |               |   |      |   |                 |   |
|--|---------------|---|------|---|-----------------|---|
|  |               |   |      |   | mode            |   |
|  | Setting range | 0: Enable position deviation fault detection<br>1: Disable position deviation fault detection | Unit | - | Factory setting | 0 |

|                  |               |  |      |              |                 |         |
|------------------|---------------|--|------|--------------|-----------------|---------|
| P03.25<br>P03.26 | Name          | Position deviation fault detection threshold |      |              | Related mode    | P       |
|                  | Setting range | 1~1073741824                                 | Unit | Encoder unit | Factory setting | 1310720 |

Set the fault threshold for excessive position deviation in position control mode. When the position deviation of the servo motor is greater than the threshold, the servo drive will generate AL.240 (excessive position deviation). P03.25 and P03.26 are combined into a 32-bit value, where P03.25 is the low 16-bit value, and P03.26 is the high 16-bit value. Subsequent use P03.25 to represent the 32-bit parameter.

|        |               |         |      |   |                 |   |
|--------|---------------|---------|------|---|-----------------|---|
| P03.27 | Name          | Reserve |      |   | Related mode    | - |
|        | Setting range | -       | Unit | - | Factory setting | - |

|                  |               |                        |      |              |                 |       |
|------------------|---------------|------------------------|------|--------------|-----------------|-------|
| P03.28<br>P03.29 | Name          | Step operation         |      |              | Related mode    | P     |
|                  | Setting range | -1073741824~1073741824 | Unit | Command unit | Factory setting | 10000 |

Set the position command source as the number of position commands in step operation (P03.00=00). P03.28 and P03.29 are combined into a 32-bit value, where P03.28 is the low 16-bit value, and P03.29 is the high 16-bit value. Subsequent use P03.28 to represent the 32-bit parameter. Motor displacement=P03.28×electronic gear ratio. The positive or negative of P03.28 determines the positive or negative of the motor speed.

|        |               |                      |      |     |                 |      |
|--------|---------------|----------------------|------|-----|-----------------|------|
| P03.30 | Name          | Step operation speed |      |     | Related mode    | P    |
|        | Setting range | 0~6000               | Unit | rpm | Factory setting | 1000 |

Set the maximum operating speed during stepping operation.

|        |               |   |      |    |                 |     |
|--------|---------------|---|------|----|-----------------|-----|
| P03.31 | Name          | Step operation acceleration time constant |      |    | Related mode    | P   |
|        | Setting range | 1~65535                                   | Unit | ms | Factory setting | 200 |

Set the variable speed time when the motor speed is changed from 0rpm to 1000rpm during step operation.

|        |               |   |      |    |                 |     |
|--------|---------------|---|------|----|-----------------|-----|
| P03.32 | Name          | Step operation deceleration time constant |      |    | Related mode    | P   |
|        | Setting range | 1~65535                                   | Unit | ms | Factory setting | 200 |

Set the variable speed time when the motor speed is changed from 1000rpm to 0rpm during step operation.

|        |               |                       |      |   |                 |   |
|--------|---------------|-----------------------|------|---|-----------------|---|
| P03.40 | Name          | Homing enable control |      |   | Related mode    | P |
|        | Setting range | 0~6                   | Unit | - | Factory setting | 1 |

Set the homing mode and trigger signal source.

| Set value | Speed command source  | Remark                    |   |
|-----------|---|---------------------------|---|
|           |   | Homing mode               | Trigger signal  |
| 0         | Close the homing  | Prohibit return to origin | No  |
| 1         | Input the "homing start" signal through the IN terminal to enable the origin back to zero     | Origin back to zero       | IN signal FunIN.22 (homing start)   |
| 2         | Input the "homing start" signal through the IN terminal to enable the electrical back to zero | Electrical return to zero | IN signal FunIN.22 (homing start)   |
| 3         | Start the homing immediately after power-on   | Origin back to zero       | The driver is powered on and enabled for the first time                     |
| 4         | Immediately origin back to zero   | Origin back to zero       | The driver is enabled, after returning to the origin is completed, P03.40=0 |
| 5         | Immediately electrical return to zero   | Electrical return to zero | The driver is enabled, after returning to the origin is completed, P03.40=0 |
| 6         | Take the current position as the origin   | Origin back to zero       | The driver is enabled, after returning to the origin is completed, P03.40=0 |

|        |               |                       |      |   |                 |   |
|--------|---------------|-----------------------|------|---|-----------------|---|
| P03.41 | Name          | Homing mode selection |      |   | Related mode    | P |
|        | Setting range | 0~13                  | Unit | - | Factory setting | 0 |

Set the motor rotation direction, deceleration point and origin when returning to the origin.

| Set value | Speed command source |                           |                           | Remark   |
|-----------|----------------------|---------------------------|---------------------------|--|
|           | Homing direction     | Deceleration point        | Origin                    |  |
| 0         | Forward              | Origin switch             | Origin switch             | Forward/reverse: consistent with the definition of P01.01 (rotation direction selection);<br>Origin switch: IN function FunIN.23 (origin switch signal). |
| 1         | Reverse              | Origin switch             | Origin switch             |  |
| 2         | Forward              | Positive limit            | Positive limit            | Positive limit switch: IN function FunIN.5 (positive limit signal)   |
| 3         | Reverse              | Negative limit            | Negative limit            | Negative limit switch: IN function FunIN.6 (negative limit signal)   |
| 4         | Forward              | Mechanical limit position | Mechanical limit position | Use torque mode to return to zero  |
| 5         | Reverse              | Mechanical limit position | Mechanical limit position |  |
| Other     | Reserve              | Reserve                   | Reserve                   | Reserve  |

|        |               |  |      |     |                 |     |
|--------|---------------|--|------|-----|-----------------|-----|
| P03.42 | Name          | High speed search origin switch signal speed |      |     | Related mode    | P   |
|        | Setting range | 0~3000                                       | Unit | rpm | Factory setting | 100 |

Set the motor speed when the origin is back to zero and search the origin signal at high speed.

|        |      |   |  |  |         |   |
|--------|------|---|--|--|---------|---|
| P03.43 | Name | Low speed search origin switch signal speed |  |  | Related | P |
|--------|------|---|--|--|---------|---|

|  |               |        |      |      |                       |
|--|---------------|--------|------|------|-----------------------|
|  |               |        |      | mode |                       |
|  | Setting range | 0~1000 | Unit | rpm  | Factory setting<br>50 |

Set the motor speed when the origin is back to zero and the signal of the deceleration point is searched at low speed.

|        |               |  |      |    |                 |     |
|--------|---------------|--|------|----|-----------------|-----|
| P03.44 | Name          | Search for the acceleration and deceleration time constant of the zero switch signal |      |    | Related mode    | P   |
|        | Setting range | 1~65535  | Unit | ms | Factory setting | 100 |

Set the time for the speed to change uniformly from 0rpm to 1000rpm when the origin is back to zero.

|        |               |         |      |   |                 |   |
|--------|---------------|---------|------|---|-----------------|---|
| P03.45 | Name          | Reserve |      |   | Related mode    | - |
|        | Setting range | -       | Unit | - | Factory setting | - |

|                  |               |                          |      |               |                 |   |
|------------------|---------------|--------------------------|------|---------------|-----------------|---|
| P03.46<br>P03.47 | Name          | Mechanical origin offset |      |               | Related mode    | P |
|                  | Setting range | -1073741824~1073741824   | Unit | Command pulse | Factory setting | 0 |

Set the offset relationship between the mechanical origin and the mechanical zero when returning to the origin. Among them, P03.46 is the low 16-bit value, and P03.47 is the high 16-bit value. The two are combined into a signed 32-bit integer value. Subsequent use P03.46 to represent the 32-bit integer value.

|        |               |  |      |   |                 |   |
|--------|---------------|--|------|---|-----------------|---|
| P03.49 | Name          | Mechanical origin offset and limit processing method |      |   | Related mode    | P |
|        | Setting range | 0~3  | Unit | - | Factory setting | 0 |

Set the offset relationship between the mechanical origin and the mechanical zero when returning to the origin.

| Set value | Mechanical origin offset processing method  | Remark  |  |
|-----------|---|---|--|
|           |   | Mechanical origin   | Limit processing method  |
| 0         | P03.46 is the coordinate after the origin return, when the limit is met, the origin return is triggered again and the origin return is enabled to find the origin in the reverse direction. | The machine origin does not coincide with the machine zero point. After the origin return is completed, the motor stops at the machine origin, and the machine origin coordinate is forced to P03.46. | Give the origin return trigger signal again, the servo will perform the origin return in the reverse direction |
| 1         | P03.46 is the relative offset after homing. Retrigger the homing when the limit is met, and find the homing in the reverse direction after the homing is enabled.                           | The mechanical origin coincides with the mechanical zero point. After the motor locates the mechanical origin, it will continue to move the displacement set by P03.46 and then stop.                 | Give the origin return trigger signal again, the servo will perform the origin return in the reverse direction |
| 2         | P03.46 is the coordinate after the origin return, and it will automatically change in the reverse direction when it encounters a limit.   | The machine origin does not coincide with the machine zero point. After the origin return is completed, the motor stops at the machine origin, and the machine origin coordinate is forced to P03.46. | Servo automatically reverses, continue to perform home return  |
| 3         | P03.46 is the relative offset after the origin return, and it will  | The mechanical origin coincides with the mechanical   | Servo automatically reverses, continue to perform home   |

|  |   |   |        |
|--|---|---|--------|
|  | automatically change in the reverse direction when it encounters a limit. | zero point. After the motor locates the mechanical origin, it will continue to move the displacement se | return |
|--|---|---|--------|

|   |               |  |      |    |                 |     |
|---|---------------|--|------|----|-----------------|-----|
| P03.50  | Name          | Touchdown return to zero time judgment threshold |      |    | Related mode    | P   |
|   | Setting range | 0~65535  | Unit | ms | Factory setting | 100 |
| Set the time threshold for judging that the load reaches the mechanical position in the process of touch stop back to zero. |               |  |      |    |                 |     |

|  |               |   |      |     |                 |    |
|--|---------------|---|------|-----|-----------------|----|
| P03.51   | Name          | Touchdown return to zero speed judgment threshold |      |     | Related mode    | P  |
|  | Setting range | 0~1000  | Unit | rpm | Factory setting | 10 |
| Set the speed threshold for judging that the load reaches the mechanical position in the process of touch stop back to zero. |               |   |      |     |                 |    |

|   |               |  |      |   |                 |    |
|---|---------------|--|------|---|-----------------|----|
| P03.52  | Name          | Touch stop and return to zero torque limit |      |   | Related mode    | P  |
|   | Setting range | 0~100                                      | Unit | % | Factory setting | 50 |
| Set the maximum positive and negative torque limits during touch stop back to zero. |               |  |      |   |                 |    |

|  |               |   |      |   |                 |   |
|--|---------------|---|------|---|-----------------|---|
| P03.53   | Name          | Communication control position command type |      |   | Related mode    | P |
|  | Setting range | 0~1   | Unit | - | Factory setting | 0 |
| It is set in the position control mode (P01.00=0), and the position command source is set to the position command type when communication control (P03.00=4).<br>0: Incremental position mode<br>1: Absolute position mode |               |   |      |   |                 |   |

|  |               |  |      |    |                 |     |
|--|---------------|--|------|----|-----------------|-----|
| P03.54   | Name          | Communication control acceleration time constant |      |    | Related mode    | P   |
|  | Setting range | 1~65535  | Unit | ms | Factory setting | 100 |
| Set the time for the motor speed to uniformly accelerate from 0rpm to 1000rpm in the communication control mode. |               |  |      |    |                 |     |

|  |               |  |      |    |                 |     |
|--|---------------|--|------|----|-----------------|-----|
| P03.55   | Name          | Communication control deceleration time constant |      |    | Related mode    | P   |
|  | Setting range | 1~65535  | Unit | ms | Factory setting | 100 |
| Set the time for the motor speed to uniformly decelerate from 1000rpm to 0rpm in the communication control mode. |               |  |      |    |                 |     |



|   |               |                                       |      |     |                 |     |
|---|---------------|---------------------------------------|------|-----|-----------------|-----|
| P03.56  | Name          | Communication control operating speed |      |     | Related mode    | P   |
|   | Setting range | 0~6000                                | Unit | rpm | Factory setting | 500 |
| Set the maximum operating speed of the motor in the communication control mode. |               |                                       |      |     |                 |     |

|   |               |  |      |              |                 |       |
|---|---------------|--|------|--------------|-----------------|-------|
| P03.57<br>P03.58  | Name          | Communication control position command |      |              | Related mode    | P     |
|   | Setting range | -1073741824~1073741824                 | Unit | Command unit | Factory setting | 10000 |
| Set the position command of the motor in the communication control mode. Among them, P03.57 is the low 16-bit value, and P03.58 is the high 16-bit value. The two form a 32-bit signed integer value. |               |  |      |              |                 |       |
| <ul style="list-style-type: none"> <li><b>Note: In communication control mode, the upper computer triggers the operation of the motor by writing P03.58.</b></li> </ul>                               |               |  |      |              |                 |       |

### 5.5 Group P04: Speed control parameters

|                                      |               |                                |   |   |                 |   |
|--------------------------------------|---------------|--------------------------------|---|---|-----------------|---|
| P04.00                               | Name          | Speed command source selection |   |   | Related mode    | S |
|                                      | Setting range | 0~10                           | Unit  | - | Factory setting | 0 |
| Set the source of the speed command. |               |                                |   |   |                 |   |
|                                      | Set value     | Speed command source           | Command acquisition method  |   |                 |   |
|                                      | 0             | Number given                   | The motor running speed is set by P04.01, and the operation is triggered by the servo enable signal                                     |   |                 |   |
|                                      | 1             | Multi-segment position command | The multi-segment position operation mode is set by the P10 group parameters, and the operation is triggered by the servo enable signal |   |                 |   |
|                                      | 2             | Communication control          | Communication given position, speed and other parameters as well as start and stop command  |   |                 |   |
|                                      | 3             | IO control                     | Control the JOG forward and reverse rotation of the motor through the IN terminal input signal  |   |                 |   |
|                                      | 4             | Analog control                 | Control the forward and reverse rotation of the motor through the analog input voltage  |   |                 |   |
|                                      | 5~10          | Reserve                        | Don't set   |   |                 |   |

|  |               |                                   |      |     |                 |      |
|--|---------------|-----------------------------------|------|-----|-----------------|------|
| P04.01   | Name          | Speed command digital given value |      |     | Related mode    | S    |
|  | Setting range | -6000~6000                        | Unit | rpm | Factory setting | 1000 |
| Set the speed command source as the speed command value when digital setting (P04.00=0). The running acceleration time constant and deceleration time constant are set by P04.04 and P04.05. |               |                                   |      |     |                 |      |

|   |               |                               |      |   |                 |   |
|---|---------------|-------------------------------|------|---|-----------------|---|
| P04.02  | Name          | Analog input channel settings |      |   | Related mode    | S |
|   | Setting range | 0~1                           | Unit | - | Factory setting | 0 |
| When P04.00=4, which analog input channel needs to be used as the analog voltage source for motor speed control<br>0: A11 channel |               |                               |      |   |                 |   |

1: AI2 channel

|        |               |                         |      |     |                 |      |
|--------|---------------|-------------------------|------|-----|-----------------|------|
| P04.04 | Name          | Jog speed setting value |      |     | Related mode    | S    |
|        | Setting range | 0~6000                  | Unit | rpm | Factory setting | 1000 |

When setting the keystroke jog function of the servo driver, set the jog speed command value. To use the keystroke jog function of the servo driver, please set the servo enable to OFF. The operation acceleration time constant and deceleration time constant are set by P04.04 and P04.05.

|        |               |  |      |    |                 |     |
|--------|---------------|--|------|----|-----------------|-----|
| P04.05 | Name          | Speed command acceleration time constant |      |    | Related mode    | S   |
|        | Setting range | 1~65535                                  | Unit | ms | Factory setting | 200 |

Set the time for the speed to change uniformly from 0rpm to 1000rpm when P04.01 and P04.04 are in motion.

|        |               |  |      |    |                 |     |
|--------|---------------|--|------|----|-----------------|-----|
| P04.06 | Name          | Speed command deceleration time constant |      |    | Related mode    | S   |
|        | Setting range | 1~65535                                  | Unit | ms | Factory setting | 200 |

Set the time for the speed to change uniformly from 1000rpm to 0rpm when P04.01 and P04.04 are in motion.

|        |               |                                  |      |     |                 |    |
|--------|---------------|----------------------------------|------|-----|-----------------|----|
| P04.07 | Name          | Zero speed clamp speed threshold |      |     | Related mode    | S  |
|        | Setting range | 0~3000                           | Unit | rpm | Factory setting | 10 |

Set the speed threshold for the zero-speed clamp operation to take effect only when the actual motor speed is lower than the set value.

**Note: The host computer gives a zero-speed clamp signal, and when the actual motor speed is lower than the set value, the motor is clamped at the current position.**

|        |               |                                       |      |     |                 |      |
|--------|---------------|---------------------------------------|------|-----|-----------------|------|
| P04.14 | Name          | Speed reaches the detection threshold |      |     | Related mode    | -    |
|        | Setting range | 0~6000                                | Unit | rpm | Factory setting | 1000 |

When the filtered absolute value of the actual speed of the servo motor exceeds the threshold set by P04.14, it is considered that the actual speed of the servo motor has reached the desired value, and the servo driver can output a speed arrival signal at this time. On the contrary, if the absolute value of the actual speed of the servo motor after filtering is not greater than this value, the speed arrival signal is invalid. The judgment of the speed arrival signal is not affected by the operating state and control mode of the driver.

|        |      |         |  |  |              |   |
|--------|------|---------|--|--|--------------|---|
| P04.15 | Name | Reserve |  |  | Related mode | - |
|--------|------|---------|--|--|--------------|---|

|                  |               |  |      |     |                 |     |
|------------------|---------------|--|------|-----|-----------------|-----|
|                  | Setting range | -  | Unit | -   | Factory setting | -   |
| P04.16           | Name          | Speed mode jog forward speed                 |      |     | Related mode    | S   |
|                  | Setting range | 0~6000                                       | Unit | rpm | Factory setting | 200 |
| P04.17           | Name          | Speed mode jog reversal speed                |      |     | Related mode    | S   |
|                  | Setting range | 0~6000                                       | Unit | rpm | Factory setting | 200 |
| P04.18           | Name          | Speed mode jog acceleration time constant    |      |     | Related mode    | S   |
|                  | Setting range | 1~65535                                      | Unit | ms  | Factory setting | 100 |
| P04.19           | Name          | Speed mode jog deceleration time constant    |      |     | Related mode    | S   |
|                  | Setting range | 1~65535                                      | Unit | ms  | Factory setting | 100 |
| P04.20           | Name          | Position mode jog forward speed              |      |     | Related mode    | P   |
|                  | Setting range | 0~6000                                       | Unit | rpm | Factory setting | 200 |
| P04.21           | Name          | Position mode jog reversal speed             |      |     | Related mode    | P   |
|                  | Setting range | 0~6000                                       | Unit | rpm | Factory setting | 200 |
| P04.22           | Name          | Position mode jog acceleration time constant |      |     | Related mode    | P   |
|                  | Setting range | 1~65535                                      | Unit | ms  | Factory setting | 100 |
| P04.23           | Name          | Position mode jog deceleration time constant |      |     | Related mode    | P   |
|                  | Setting range | 1~65535                                      | Unit | ms  | Factory setting | 100 |
| P04.24<br>P04.25 | Name          | Position mode fixed length stroke            |      |     | Related mode    | P   |

|   |               |   |                             |               |                 |       |
|---|---------------|---|-----------------------------|---------------|-----------------|-------|
|   | Setting range | 0~1073741824                                      | Unit                        | Command pulse | Factory setting | 10000 |
| P04.60<br>P04.61  | Name          | Communication control command pulse number        |                             |               | Related mode    | S     |
|   | Setting range | 0~1073741824                                      | Unit                        | Command pulse | Factory setting | 50000 |
| P04.62  | Name          | Communication control speed                       |                             |               | Related mode    | S     |
|   | Setting range | 0~6000  | Unit                        | rpm           | Factory setting | 1000  |
| P04.63  | Name          | Communication control acceleration time constant  |                             |               | Related mode    | S     |
|   | Setting range | 1~65535   | Unit                        | ms            | Factory setting | 200   |
| Set the time for the speed to change uniformly from 0rpm to 1000rpm in internal test. |               |   |                             |               |                 |       |
| P04.64  | Name          | Communication control deceleration time constant  |                             |               | Related mode    | S     |
|   | Setting range | 1~65535   | Unit                        | ms            | Factory setting | 200   |
| Set the time for the speed to change uniformly from 1000rpm to 0rpm in internal test. |               |   |                             |               |                 |       |
| P04.65  | Name          | Communication control operation mode              |                             |               | Related mode    | S     |
|   | Setting range | 0~1   | Unit                        | -             | Factory setting | 0     |
| Set the operating mode of the internal test run.                                      |               |   |                             |               |                 |       |
|   |               | Set value   | Operating mode              |               |                 |       |
|   |               | 0   | Motor reciprocating         |               |                 |       |
|   |               | 1   | Motor runs in one direction |               |                 |       |
| P04.66  | Name          | Communication control initial operation direction |                             |               | Related mode    | S     |
|   | Setting range | 0~1   | Unit                        | -             | Factory setting | 0     |
| Set the initial running direction of the internal test run.                           |               |   |                             |               |                 |       |
|   |               | Set value   | Starting direction          |               |                 |       |
|   |               | 0   | Positive direction          |               |                 |       |
|   |               | 1   | Negative direction          |               |                 |       |
| P04.67  | Name          | Communication control operation times             |                             |               | Related mode    | S     |

|   |               |           |                             |   |                 |   |
|---|---------------|-----------|-----------------------------|---|-----------------|---|
|   | Setting range | 0~65535   | Unit                        | - | Factory setting | 0 |
| Set the running times of the communication control operation. In the reciprocating operation mode, the motor reciprocates completely once, and the number of runs is counted once. In unidirectional running mode, the motor stops after running and counts the number of runs. |               |           |                             |   |                 |   |
|   |               | Set value | Starting direction          |   |                 |   |
|   |               | 0         | Unlimited times             |   |                 |   |
|   |               | 1~65535   | Run the set number of times |   |                 |   |

|        |               |                           |      |     |                 |     |
|--------|---------------|---------------------------|------|-----|-----------------|-----|
| P04.68 | Name          | Open loop operation speed |      |     | Related mode    | -   |
|        | Setting range | 0~3000                    | Unit | rpm | Factory setting | 100 |

|        |               |                                  |      |       |                 |    |
|--------|---------------|----------------------------------|------|-------|-----------------|----|
| P04.69 | Name          | Open loop operation acceleration |      |       | Related mode    | -  |
|        | Setting range | 1~100                            | Unit | r/s^2 | Factory setting | 10 |

|        |               |                                  |      |       |                 |    |
|--------|---------------|----------------------------------|------|-------|-----------------|----|
| P04.70 | Name          | Open loop operation deceleration |      |       | Related mode    | -  |
|        | Setting range | 1~100                            | Unit | r/s^2 | Factory setting | 10 |

|        |       |                            |      |   |              |    |
|--------|-------|----------------------------|------|---|--------------|----|
| P04.71 | Name  | Open loop operation torque |      |   | Related mode | -  |
|        | Range | 0~100                      | Unit | % | Defaults     | 50 |

|        |       |  |      |   |              |   |
|--------|-------|--|------|---|--------------|---|
| P04.72 | Name  | Open loop operation start-stop command |      |   | Related mode | - |
|        | Range | 0~6                                    | Unit | - | Defaults     | 0 |

Set the start-stop command for motor open-loop operation.

| Set value | Start-stop command   |
|-----------|--|
| 0         | Read: The motor is in a waiting state/in a running state<br>Write: No effect |
| 3         | Open loop forward  |
| 4         | Open loop reversal   |
| 6         | Deceleration stop  |
| Other     | Invalid  |

|        |       |                     |      |   |              |   |
|--------|-------|---------------------|------|---|--------------|---|
| P04.73 | Name  | Lock shaft position |      |   | Related mode | - |
|        | Range | 0~65535             | Unit | - | Defaults     | 0 |

|        |       |                   |      |   |              |    |
|--------|-------|-------------------|------|---|--------------|----|
| P04.74 | Name  | Lock shaft torque |      |   | Related mode | -  |
|        | Range | 0~100             | Unit | % | Defaults     | 50 |

|        |       |                               |      |   |              |   |
|--------|-------|-------------------------------|------|---|--------------|---|
| P04.75 | Name  | Lock shaft start-stop command |      |   | Related mode | - |
|        | Range | 0~1                           | Unit | - | Defaults     | 0 |

|        |       |                           |      |     |              |    |
|--------|-------|---------------------------|------|-----|--------------|----|
| P04.76 | Name  | Encoder calibration speed |      |     | Related mode | -  |
|        | Range | 1~100                     | Unit | rpm | Defaults     | 10 |

|        |       |                                  |      |                  |              |   |
|--------|-------|----------------------------------|------|------------------|--------------|---|
| P04.77 | Name  | Encoder calibration acceleration |      |                  | Related mode | - |
|        | Range | 1~10                             | Unit | r/s <sup>2</sup> | Defaults     | 1 |

|        |       |                                  |      |                  |              |   |
|--------|-------|----------------------------------|------|------------------|--------------|---|
| P04.78 | Name  | Encoder calibration deceleration |      |                  | Related mode | - |
|        | Range | 1~10                             | Unit | r/s <sup>2</sup> | Defaults     | 1 |

When setting the internal test, the motor speed is changed uniformly from 1000rpm to 0rpm.

|        |       |                            |      |   |              |    |
|--------|-------|----------------------------|------|---|--------------|----|
| P04.79 | Name  | Encoder calibration torque |      |   | Related mode | -  |
|        | Range | 0~100                      | Unit | % | Defaults     | 85 |

|        |       |                                   |      |   |              |   |
|--------|-------|-----------------------------------|------|---|--------------|---|
| P04.80 | Name  | Encoder calibration start command |      |   | Related mode | - |
|        | Range | 0~2                               | Unit | % | Defaults     | 0 |

|        |       |   |      |   |              |         |
|--------|-------|---|------|---|--------------|---------|
| P04.81 | Name  | Encoder receiving insufficient data fault counter |      |   | Related mode | Display |
|        | Range | -   | Unit | - | Defaults     | -       |

|        |       |   |      |   |              |         |
|--------|-------|---|------|---|--------------|---------|
| P04.82 | Name  | Encoder receiving disconnection fault counter |      |   | Related mode | Display |
|        | Range | -   | Unit | - | Defaults     | -       |

|        |       |                                     |      |   |              |         |
|--------|-------|-------------------------------------|------|---|--------------|---------|
| P04.83 | Name  | Encoder receiving CRC fault counter |      |   | Related mode | Display |
|        | Range | -                                   | Unit | - | Defaults     | -       |

|        |      |  |  |  |              |         |
|--------|------|--|--|--|--------------|---------|
| P04.84 | Name | Encoder receiving module fault counter |  |  | Related mode | Display |
|--------|------|--|--|--|--------------|---------|

|  |       |   |      |   |          |   |
|--|-------|---|------|---|----------|---|
|  | Range | - | Unit | - | Defaults | - |
|--|-------|---|------|---|----------|---|

|        |       |  |      |   |              |         |
|--------|-------|--|------|---|--------------|---------|
| P04.85 | Name  | Encoder receiving continuous fault counter |      |   | Related mode | Display |
|        | Range | -  | Unit | - | Defaults     | -       |

**5.6 Group P05: Torque control parameters**

|        |       |                         |      |   |              |   |
|--------|-------|-------------------------|------|---|--------------|---|
| P05.00 | Name  | Torque command source A |      |   | Related mode | T |
|        | Range | 0~2                     | Unit | - | Defaults     | 0 |

Set the command source of torque command source A.

| Set value | Torque command source    |
|-----------|--------------------------|
| 0         | Digital setting (P05.03) |
| 1         | Analog channel AI1       |
| 2         | Analog channel AI2       |

|        |       |                         |      |   |              |   |
|--------|-------|-------------------------|------|---|--------------|---|
| P05.01 | Name  | Torque command source B |      |   | Related mode | T |
|        | Range | 0~2                     | Unit | - | Defaults     | 0 |

Set the command source of torque command source B.

| Set value | Torque command source    |
|-----------|--------------------------|
| 0         | Digital setting (P05.03) |
| 1         | Analog channel AI1       |
| 2         | Analog channel AI2       |

|        |       |                       |      |   |              |   |
|--------|-------|-----------------------|------|---|--------------|---|
| P05.02 | Name  | Torque command source |      |   | Related mode | T |
|        | Range | 0~3                   | Unit | - | Defaults     | 0 |

Set the command source of torque command source .

| Set value | Torque command source                 |
|-----------|---------------------------------------|
| 0         | Command source A                      |
| 1         | Command source B                      |
| 2         | Communication command Source (P05.20) |
| 3         | Command source A or B                 |

|        |       |                                  |      |      |              |     |
|--------|-------|----------------------------------|------|------|--------------|-----|
| P05.03 | Name  | Torque command digital set value |      |      | Related mode | T   |
|        | Range | -3000~3000                       | Unit | 0.1% | Defaults     | 200 |

Set the torque command value when the torque command source is digital setting (P05.00=0). 100% corresponds to 1 times the rated torque of the motor

|        |      |                        |  |  |              |   |
|--------|------|------------------------|--|--|--------------|---|
| P05.04 | Name | Driver overload factor |  |  | Related mode | T |
|--------|------|------------------------|--|--|--------------|---|

|  |       |        |      |      |          |      |
|--|-------|--------|------|------|----------|------|
|  | Range | 0~3000 | Unit | 0.1% | Defaults | 3000 |
| Set the maximum torque command of the servo driver. 100% corresponds to 1 times the rated torque of the motor. |       |        |      |      |          |      |

|   |       |             |      |        |              |      |
|---|-------|-------------|------|--------|--------------|------|
| P05.05  | Name  | Torque ramp |      |        | Related mode | T    |
|   | Range | 1~65535     | Unit | 0.1%/s | Defaults     | 3000 |
| Set the increment of the torque command. A setting value of 3000 means that the torque command is evenly increased by 300% of the rated torque within 1s. |       |             |      |        |              |      |

|        |       |                                |      |   |              |   |
|--------|-------|--------------------------------|------|---|--------------|---|
| P05.06 | Name  | Torque limit source (reserved) |      |   | Related mode | T |
|        | Range | 0~4                            | Unit | - | Defaults     | 0 |

|        |       |   |      |   |              |   |
|--------|-------|---|------|---|--------------|---|
| P05.07 | Name  | Torque limit source AI channel (reserved) |      |   | Related mode | T |
|        | Range | 0~1                                       | Unit | - | Defaults     | 0 |

|        |       |  |      |      |              |      |
|--------|-------|--|------|------|--------------|------|
| P05.08 | Name  | Internal forward torque limit (reserved) |      |      | Related mode | T    |
|        | Range | 0~3000                                   | Unit | 0.1% | Defaults     | 3000 |

|        |       |   |      |      |              |      |
|--------|-------|---|------|------|--------------|------|
| P05.09 | Name  | Internal negative torque limit (reserved) |      |      | Related mode | T    |
|        | Range | 0~3000                                    | Unit | 0.1% | Defaults     | 3000 |

|        |       |  |      |      |              |      |
|--------|-------|--|------|------|--------------|------|
| P05.10 | Name  | External forward torque limit (reserved) |      |      | Related mode | T    |
|        | Range | 0~3000                                   | Unit | 0.1% | Defaults     | 3000 |

|        |       |   |      |      |              |      |
|--------|-------|---|------|------|--------------|------|
| P05.11 | Name  | External negative torque limit (reserved) |      |      | Related mode | T    |
|        | Range | 0~3000                                    | Unit | 0.1% | Defaults     | 3000 |

|  |       |                       |      |   |              |   |
|--|-------|-----------------------|------|---|--------------|---|
| P05.12   | Name  | Source of speed limit |      |   | Related mode | T |
|  | Range | 0~1                   | Unit | - | Defaults     | 0 |
| Set the source of speed limit in torque mode:<br>0: Internal setting (P05.14/P05.15)<br>1: External analog quantity (reserved) |       |                       |      |   |              |   |

|        |      |  |  |  |              |   |
|--------|------|--|--|--|--------------|---|
| P05.13 | Name | Speed limit analog channel source (reserved) |  |  | Related mode | T |
|--------|------|--|--|--|--------------|---|



|  |       |     |      |   |          |   |
|--|-------|-----|------|---|----------|---|
|  | Range | 0~1 | Unit | - | Defaults | 0 |
|--|-------|-----|------|---|----------|---|

|   |       |  |      |     |              |      |
|---|-------|--|------|-----|--------------|------|
| P05.14  | Name  | Torque control forward speed limit value |      |     | Related mode | T    |
|   | Range | 0~6000                                   | Unit | rpm | Defaults     | 3000 |
| Set the forward speed limit value in torque control mode. |       |  |      |     |              |      |

|   |       |   |      |     |              |      |
|---|-------|---|------|-----|--------------|------|
| P05.15  | Name  | Torque control negative speed limit value |      |     | Related mode | T    |
|   | Range | 0~6000                                    | Unit | rpm | Defaults     | 3000 |
| Set the reverse speed limit value in torque control mode. |       |   |      |     |              |      |

|        |       |                                    |      |      |              |   |
|--------|-------|------------------------------------|------|------|--------------|---|
| P05.16 | Name  | Torque reaches the reference value |      |      | Related mode | T |
|        | Range | 0~65535                            | Unit | 0.1% | Defaults     | 0 |

|        |       |                                |      |      |              |     |
|--------|-------|--------------------------------|------|------|--------------|-----|
| P05.17 | Name  | Torque reaches the valid value |      |      | Related mode | T   |
|        | Range | 0~65535                        | Unit | 0.1% | Defaults     | 100 |

|        |       |                                  |      |      |              |    |
|--------|-------|----------------------------------|------|------|--------------|----|
| P05.18 | Name  | Torque reaches the invalid value |      |      | Related mode | T  |
|        | Range | 0~65535                          | Unit | 0.1% | Defaults     | 50 |

|        |       |  |      |    |              |    |
|--------|-------|--|------|----|--------------|----|
| P05.19 | Name  | Torque reaches signal valid detection time |      |    | Related mode | T  |
|        | Range | 0~65535                                    | Unit | ms | Defaults     | 50 |

|        |       |                                    |      |      |              |     |
|--------|-------|------------------------------------|------|------|--------------|-----|
| P05.20 | Name  | Communication given torque command |      |      | Related mode | T   |
|        | Range | 0~3000                             | Unit | 0.1% | Defaults     | 200 |

|  |       |   |      |    |              |     |
|--|-------|---|------|----|--------------|-----|
| P05.21   | Name  | Torque running acceleration time constant |      |    | Related mode | T   |
|  | Range | 1~65535                                   | Unit | ms | Defaults     | 100 |
| It takes effect when P05.26 is set to 1, and it is another processing method for torque mode. The set value is expressed as the time for the motor speed to uniformly accelerate from 0 rpm to 1000 rpm. |       |   |      |    |              |     |

|  |       |   |      |    |              |     |
|--|-------|---|------|----|--------------|-----|
| P05.22   | Name  | Torque running deceleration time constant |      |    | Related mode | T   |
|  | Range | 1~65535                                   | Unit | ms | Defaults     | 100 |
| It takes effect when P05.26 is set to 1, and it is another processing method for torque mode. The set value is expressed as the time for the motor speed to decelerate uniformly from 1000 rpm to 0 rpm. |       |   |      |    |              |     |

|   |       |                     |      |    |              |     |
|---|-------|---------------------|------|----|--------------|-----|
| P05.23  | Name  | Torque holding time |      |    | Related mode | T   |
|   | Range | 0~65535             | Unit | ms | Defaults     | 500 |
| It takes effect when P05.26 is set to 1, and it is another processing method for torque mode. The set value indicates that after the torque is reached and maintained for the set time, the state of the motor shaft will be transformed into a position-locked shaft or a free state according to the set value of P05.24. |       |                     |      |    |              |     |

0: Keep running in torque mode until the upper computer gives a torque stop signal  
 Others: switch the running state after the torque is maintained for the set time

|  |       |                                      |      |   |              |   |
|--|-------|--------------------------------------|------|---|--------------|---|
| P05.24   | Name  | Working mode after torque is reached |      |   | Related mode | T |
|  | Range | 0~3                                  | Unit | - | Defaults     | 0 |
| It takes effect when P05.26 is set to 1, and it is another processing method for torque mode. The set value indicates that after the torque reaches and maintains the setting time of P05.23, the state of the motor shaft will be transformed into a position-locked shaft or a free state according to the set value of P05.24.<br>0: Free state (0 torque output state)<br>Other: No other processing |       |                                      |      |   |              |   |

|  |       |   |      |   |              |   |
|--|-------|---|------|---|--------------|---|
| P05.25   | Name  | Communication triggers torque operation |      |   | Related mode | T |
|  | Range | 0~2                                     | Unit | - | Defaults     | 0 |
| It takes effect when P05.26 is set to 1, and it is another processing method for torque mode.<br>0: Stop<br>1: Forward rotation start<br>2: Reversal start |       |   |      |   |              |   |

|        |       |                                      |      |   |              |   |
|--------|-------|--------------------------------------|------|---|--------------|---|
| P05.26 | Name  | Torque mode operation mode selection |      |   | Related mode | T |
|        | Range | 0~1                                  | Unit | - | Defaults     | 0 |

|        |       |  |      |   |              |   |
|--------|-------|--|------|---|--------------|---|
| P05.33 | Name  | Torque limit detection time (reserved) |      |   | Related mode | T |
|        | Range | 0~65535                                | Unit | - | Defaults     | 0 |

|        |       |          |      |   |              |   |
|--------|-------|----------|------|---|--------------|---|
| P05.34 | Name  | Reserved |      |   | Related mode | T |
|        | Range | -        | Unit | - | Defaults     | - |

|        |       |          |      |   |              |   |
|--------|-------|----------|------|---|--------------|---|
| P05.35 | Name  | Reserved |      |   | Related mode | T |
|        | Range | -        | Unit | - | Defaults     | - |

|        |       |          |      |   |              |   |
|--------|-------|----------|------|---|--------------|---|
| P05.36 | Name  | Reserved |      |   | Related mode | T |
|        | Range | -        | Unit | - | Defaults     | - |

|        |       |          |      |   |              |   |
|--------|-------|----------|------|---|--------------|---|
| P05.37 | Name  | Reserved |      |   | Related mode | T |
|        | Range | -        | Unit | - | Defaults     | - |

**5.7 Group P06: Gain parameters**

|        |       |                |      |       |              |      |
|--------|-------|----------------|------|-------|--------------|------|
| P06.00 | Name  | 1st speed gain |      |       | Related mode | -    |
|        | Range | 0~65535        | Unit | 0.1Hz | Defaults     | 4500 |

Set the proportional gain of the speed regulator. This parameter determines the response of the speed regulator. The larger the value, the faster the speed response. However, too large a value may cause vibration. In position mode, if the position gain is increased, the speed gain must be increased.

|        |       |                                  |      |       |              |      |
|--------|-------|----------------------------------|------|-------|--------------|------|
| P06.01 | Name  | 1st speed integral time constant |      |       | Related mode | -    |
|        | Range | 1~30000                          | Unit | 0.1ms | Defaults     | 3500 |

Set the integral time constant of the speed regulator. The smaller the set value, the stronger the integral effect, and the faster the speed deviation when stopping is close to zero.

- Note: When P06.01 is set to 30000, there is no integral effect

|        |       |                   |      |       |              |     |
|--------|-------|-------------------|------|-------|--------------|-----|
| P06.02 | Name  | 1st position gain |      |       | Related mode | -   |
|        | Range | 0~5000            | Unit | 0.1Hz | Defaults     | 500 |

Set the proportional gain of the position. This parameter determines the response performance of the position. Setting a larger position gain can shorten the positioning time. But too large a set value may cause mechanical vibration.

|        |       |                |      |       |              |      |
|--------|-------|----------------|------|-------|--------------|------|
| P06.03 | Name  | 2nd speed gain |      |       | Related mode | -    |
|        | Range | 0~65535        | Unit | 0.1Hz | Defaults     | 4500 |

|        |       |                                  |      |       |              |      |
|--------|-------|----------------------------------|------|-------|--------------|------|
| P06.04 | Name  | 2nd speed integral time constant |      |       | Related mode | -    |
|        | Range | 1~30000                          | Unit | 0.1ms | Defaults     | 3500 |

|        |       |                   |      |       |              |     |
|--------|-------|-------------------|------|-------|--------------|-----|
| P06.05 | Name  | 2nd position gain |      |       | Related mode | -   |
|        | Range | 0~5000            | Unit | 0.1Hz | Defaults     | 500 |

|        |       |         |      |   |              |   |
|--------|-------|---------|------|---|--------------|---|
| P06.06 | Name  | Skd     |      |   | Related mode | - |
|        | Range | 0~65535 | Unit | - | Defaults     | 0 |

|        |       |         |      |   |              |      |
|--------|-------|---------|------|---|--------------|------|
| P06.07 | Name  | Skr     |      |   | Related mode | -    |
|        | Range | 0~65535 | Unit | - | Defaults     | 1000 |

|        |       |         |      |   |              |   |
|--------|-------|---------|------|---|--------------|---|
| P06.08 | Name  | Skm     |      |   | Related mode | - |
|        | Range | 0~65535 | Unit | - | Defaults     | 0 |

|        |       |         |      |   |              |   |
|--------|-------|---------|------|---|--------------|---|
| P06.09 | Name  | Pki     |      |   | Related mode | - |
|        | Range | 0~65535 | Unit | - | Defaults     | 0 |

|        |       |         |      |   |              |   |
|--------|-------|---------|------|---|--------------|---|
| P06.10 | Name  | Pkd     |      |   | Related mode | - |
|        | Range | 0~65535 | Unit | - | Defaults     | 0 |

|  |       |   |      |    |              |      |
|--|-------|---|------|----|--------------|------|
| P06.14   | Name  | Speed feedforward low-pass filter cut-off frequency |      |    | Related mode | -    |
|  | Range | 1~10000   | Unit | Hz | Defaults     | 2000 |
| Set the filter cut-off frequency of the speed feedforward. |       |   |      |    |              |      |

|  |       |   |      |      |              |   |
|--|-------|---|------|------|--------------|---|
| P06.15   | Name  | Speed feedforward low-pass filter cut-off frequency |      |      | Related mode | - |
|  | Range | 1~1000  | Unit | 0.1% | Defaults     | 0 |
| In the position control mode, multiply the speed feedforward signal by the parameter P06.15, and the result obtained becomes the speed feedforward as part of the speed command. Increasing this parameter can increase the response speed of the position command and reduce the position deviation at a fixed speed. |       |   |      |      |              |   |

|   |       |  |      |    |              |      |
|---|-------|--|------|----|--------------|------|
| P06.16  | Name  | Torque feedforward low-pass filter cut-off frequency |      |    | Related mode | -    |
|   | Range | 1~10000  | Unit | Hz | Defaults     | 2000 |
| Set the filter frequency of the torque feedforward. |       |  |      |    |              |      |

|  |       |                         |      |      |              |   |
|--|-------|-------------------------|------|------|--------------|---|
| P06.17   | Name  | Torque feedforward gain |      |      | Related mode | - |
|  | Range | 0~1000                  | Unit | 0.1% | Defaults     | 0 |
| In the non-torque control mode, multiply the torque feedforward signal by the parameter P06.17, and the result obtained becomes the torque feedforward as part of the torque command. Increasing this parameter can improve the response speed to changing speed commands. |       |                         |      |      |              |   |

|        |       |          |      |   |              |   |
|--------|-------|----------|------|---|--------------|---|
| P06.18 | Name  | Reserved |      |   | Related mode | - |
|        | Range | -        | Unit | - | Defaults     | - |

|  |       |   |      |    |              |      |
|--|-------|---|------|----|--------------|------|
| P06.19   | Name  | Speed low-pass filter cut-off frequency 1 |      |    | Related mode | -    |
|  | Range | 1~10000                                   | Unit | Hz | Defaults     | 1000 |
| Set the cut-off frequency 1 for the low-pass filter of the speed feedback value. The smaller the setting, the smaller the speed feedback fluctuation, but the larger the feedback delay. |       |   |      |    |              |      |

|        |       |   |      |    |              |      |
|--------|-------|---|------|----|--------------|------|
| P06.20 | Name  | Speed low-pass filter cut-off frequency 2 |      |    | Related mode | -    |
|        | Range | 1~10000                                   | Unit | Hz | Defaults     | 1000 |

|        |       |          |      |   |              |   |
|--------|-------|----------|------|---|--------------|---|
| P06.21 | Name  | Reserved |      |   | Related mode | - |
|        | Range | -        | Unit | - | Defaults     | - |

|        |       |  |      |    |              |      |
|--------|-------|--|------|----|--------------|------|
| P06.24 | Name  | Torque command low-pass filter cut-off frequency 1 |      |    | Related mode | -    |
|        | Range | 1~10000  | Unit | Hz | Defaults     | 1000 |

Set the torque command low-pass filter cut-off frequency. Filtering the torque command can make the torque command smoother and reduce vibration. If the filter cutoff frequency setting value is too small, the responsiveness will be reduced. Set it while confirming the responsiveness.

|        |       |          |      |   |              |   |
|--------|-------|----------|------|---|--------------|---|
| P06.25 | Name  | Reserved |      |   | Related mode | - |
|        | Range | -        | Unit | - | Defaults     | - |

|        |       |   |      |    |              |      |
|--------|-------|---|------|----|--------------|------|
| P06.26 | Name  | Torque feedback low-pass filter cut-off frequency 1 |      |    | Related mode | -    |
|        | Range | 1~10000   | Unit | Hz | Defaults     | 1000 |

Set the torque feedback low-pass filter cut-off frequency. Through the low-pass filtering of the torque feedback, the torque feedback can be made smoother and vibration can be reduced. If the set value of the filter cutoff frequency constant is too small, the responsiveness will be reduced. Set it while confirming the responsiveness.

|        |       |          |      |   |              |   |
|--------|-------|----------|------|---|--------------|---|
| P06.27 | Name  | Reserved |      |   | Related mode | - |
|        | Range | -        | Unit | - | Defaults     | - |

|        |       |                                |      |    |              |      |
|--------|-------|--------------------------------|------|----|--------------|------|
| P06.28 | Name  | Current loop proportional gain |      |    | Related mode | -    |
|        | Range | 1~50000                        | Unit | Hz | Defaults     | 1000 |

|        |       |                                     |      |       |              |      |
|--------|-------|-------------------------------------|------|-------|--------------|------|
| P06.29 | Name  | Current loop integral time constant |      |       | Related mode | -    |
|        | Range | 1~10000                             | Unit | 0.1ms | Defaults     | 1500 |

Set the integral time constant of the torque loop. The smaller the setting value, the faster the integration speed and the smaller the current tracking error. However, if the integration is too small, oscillation or noise will easily occur. When the set value is 10000, the integrator does not work.

|        |       |                           |      |    |              |      |
|--------|-------|---------------------------|------|----|--------------|------|
| P06.30 | Name  | PVIA proportional gain KP |      |    | Related mode | -    |
|        | Range | 0~50000                   | Unit | Hz | Defaults     | 3000 |

|        |       |                       |      |   |              |      |
|--------|-------|-----------------------|------|---|--------------|------|
| P06.31 | Name  | PVIA integral gain KI |      |   | Related mode | -    |
|        | Range | 0~10000               | Unit | - | Defaults     | 1000 |

|        |       |                     |      |   |              |      |
|--------|-------|---------------------|------|---|--------------|------|
| P06.32 | Name  | PVIA speed gain KV1 |      |   | Related mode | -    |
|        | Range | 0~50000             | Unit | - | Defaults     | 1000 |

|        |       |                     |      |   |              |     |
|--------|-------|---------------------|------|---|--------------|-----|
| P06.33 | Name  | PVIA speed gain KV2 |      |   | Related mode | -   |
|        | Range | 0~50000             | Unit | - | Defaults     | 100 |

|        |       |                           |      |   |              |   |
|--------|-------|---------------------------|------|---|--------------|---|
| P06.34 | Name  | PVIA acceleration gain KA |      |   | Related mode | - |
|        | Range | 0~50000                   | Unit | - | Defaults     | 0 |

|        |       |                      |      |   |              |      |
|--------|-------|----------------------|------|---|--------------|------|
| P06.35 | Name  | PVIA speed gain KVFF |      |   | Related mode | -    |
|        | Range | 0~50000              | Unit | - | Defaults     | 1000 |

|        |       |                             |      |   |              |   |
|--------|-------|-----------------------------|------|---|--------------|---|
| P06.36 | Name  | PVIA acceleration gain KAFF |      |   | Related mode | - |
|        | Range | 0~50000                     | Unit | - | Defaults     | 0 |

|        |       |  |      |   |              |      |
|--------|-------|--|------|---|--------------|------|
| P06.37 | Name  | PVIA command speed low-pass filter cut-off frequency |      |   | Related mode | -    |
|        | Range | 0~10000  | Unit | - | Defaults     | 1000 |

|        |       |   |      |   |              |      |
|--------|-------|---|------|---|--------------|------|
| P06.38 | Name  | PVIA command acceleration low-pass filter cut-off frequency |      |   | Related mode | -    |
|        | Range | 0~10000   | Unit | - | Defaults     | 2000 |

|        |       |  |      |   |              |      |
|--------|-------|--|------|---|--------------|------|
| P06.39 | Name  | PVIA feedback acceleration low-pass filter cut-off frequency |      |   | Related mode | -    |
|        | Range | 0~10000  | Unit | - | Defaults     | 2000 |

|        |       |  |      |   |              |   |
|--------|-------|--|------|---|--------------|---|
| P06.40 | Name  | PVIA enable control  |      |   | Related mode | - |
|        | Range | 0: Use the three-loop control algorithm.<br>1: Use PVIA control algorithm. | Unit | - | Defaults     | 0 |

|        |       |          |      |   |              |   |
|--------|-------|----------|------|---|--------------|---|
| P06.45 | Name  | Reserved |      |   | Related mode | - |
|        | Range | -        | Unit | - | Defaults     | - |

|        |       |          |      |   |              |   |
|--------|-------|----------|------|---|--------------|---|
| P06.46 | Name  | Reserved |      |   | Related mode | - |
|        | Range | -        | Unit | - | Defaults     | - |

|        |       |          |      |   |              |   |
|--------|-------|----------|------|---|--------------|---|
| P06.47 | Name  | Reserved |      |   | Related mode | - |
|        | Range | -        | Unit | - | Defaults     | - |

|        |       |          |      |   |              |   |
|--------|-------|----------|------|---|--------------|---|
| P06.48 | Name  | Reserved |      |   | Related mode | - |
|        | Range | -        | Unit | - | Defaults     | - |

|        |       |          |      |   |              |   |
|--------|-------|----------|------|---|--------------|---|
| P06.49 | Name  | Reserved |      |   | Related mode | - |
|        | Range | -        | Unit | - | Defaults     | - |

|        |       |          |      |   |              |   |
|--------|-------|----------|------|---|--------------|---|
| P06.50 | Name  | Reserved |      |   | Related mode | - |
|        | Range | -        | Unit | - | Defaults     | - |

|        |       |          |      |   |              |   |
|--------|-------|----------|------|---|--------------|---|
| P06.51 | Name  | Reserved |      |   | Related mode | - |
|        | Range | -        | Unit | - | Defaults     | - |

|        |       |          |      |   |              |   |
|--------|-------|----------|------|---|--------------|---|
| P06.52 | Name  | Reserved |      |   | Related mode | - |
|        | Range | -        | Unit | - | Defaults     | - |

|        |       |          |      |   |              |   |
|--------|-------|----------|------|---|--------------|---|
| P06.53 | Name  | Reserved |      |   | Related mode | - |
|        | Range | -        | Unit | - | Defaults     | - |

**5.8 Group P08: Communication parameters**

|        |       |                                  |      |   |              |   |
|--------|-------|----------------------------------|------|---|--------------|---|
| P08.00 | Name  | RS485 communication axis address |      |   | Related mode | - |
|        | Range | 1~247                            | Unit | - | Defaults     | 1 |

Set the servo drive axis address.  
 0: broadcast address. The upper computer device can write to all servo drivers through the broadcast address. The driver operates according to the broadcast data frame, but does not respond.  
 1 ~ 247: when multiple servo drivers are networking, each servo driver can only have a unique address, otherwise it will lead to abnormal communication or failure of communication.

|        |       |   |      |   |              |   |
|--------|-------|---|------|---|--------------|---|
| P08.01 | Name  | RS485 communication baud rate selection |      |   | Related mode | - |
|        | Range | 0~5                                     | Unit | - | Defaults     | 5 |

Set the communication baud rate between the servo driver and the upper computer device. The communication baud rate of the servo driver must be consistent with the communication baud rate of the upper computer device, otherwise it cannot communicate.

| Set value | Baud rate setting |
|-----------|-------------------|
| 0         | 4800 Kbps         |
| 1         | 9600 Kbps         |
| 2         | 19200 Kbps        |
| 3         | 38400 Kbps        |
| 4         | 57600 Kbps        |
| 5         | 115200 Kbps       |

|        |       |   |      |   |              |   |
|--------|-------|---|------|---|--------------|---|
| P08.02 | Name  | RS485 communication data format selection |      |   | Related mode | - |
|        | Range | 0~5                                       | Unit | - | Defaults     | 0 |

Set the data format when the servo driver communicates with the upper computer device. The data format of servo driver must be consistent with the upper computer device, otherwise it cannot communicate.

| Set value | Data Format                        |
|-----------|------------------------------------|
| 0         | 8-bit data、no parity、1 stop bit    |
| 1         | 8-bit data、no parity、2 stop bits   |
| 2         | 8-bit data、even parity、1 stop bit  |
| 3         | 8-bit data、even parity、2 stop bits |
| 4         | 8-bit data、odd parity、1 stop bit   |
| 5         | 8-bit data、odd parity、2 stop bits  |

|        |       |                                |      |   |              |   |
|--------|-------|--------------------------------|------|---|--------------|---|
| P08.05 | Name  | CAN communication axis address |      |   | Related mode | - |
|        | Range | 1~127                          | Unit | - | Defaults     | 2 |

Set the CAN communication address of servo driver.

1 ~ 127: when multiple servo drivers are networking, each servo driver can only have a unique address, otherwise it will lead to abnormal communication or failure of communication.

|        |       |                                       |      |   |              |   |
|--------|-------|---------------------------------------|------|---|--------------|---|
| P08.06 | Name  | CAN communication baud rate selection |      |   | Related mode | - |
|        | Range | 0~6                                   | Unit | - | Defaults     | 4 |



Set the communication baud rate between the servo driver and the upper computer device. The communication baud rate of the servo driver must be consistent with the communication baud rate of the upper computer device, otherwise it cannot communicate.

| Set value | Baud rate setting |
|-----------|-------------------|
| 0         | 20 Kbps           |
| 1         | 50 Kbps           |
| 2         | 100 Kbps          |
| 3         | 125 Kbps          |
| 4         | 250 Kbps          |
| 5         | 500 Kbps          |
| 6         | 1000 Kbps         |

|        |       |                                  |      |    |              |   |
|--------|-------|----------------------------------|------|----|--------------|---|
| P08.07 | Name  | CAN disconnection detection time |      |    | Related mode | - |
|        | Range | 0~65535                          | Unit | ms | Defaults     | 0 |

Set the detection time of CAN communication interruption. If no CANopen synchronization signal is received within the set time, CAN communication disconnection fault will be reported.  
 0: disconnection detection is disabled  
 Other values: delay time of disconnection detection

|        |       |  |      |   |              |   |
|--------|-------|--|------|---|--------------|---|
| P08.08 | Name  | Site address assigned by EtherCAT host |      |   | Related mode | - |
|        | Range | Display                                | Unit | - | Defaults     | - |

|        |       |  |      |   |              |   |
|--------|-------|--|------|---|--------------|---|
| P08.09 | Name  | Display the current site alias address of the driver |      |   | Related mode | - |
|        | Range | Display  | Unit | - | Defaults     | - |

|        |       |  |      |   |              |   |
|--------|-------|--|------|---|--------------|---|
| P08.10 | Name  | Set the EtherCAT communication station of the driver |      |   | Related mode | - |
|        | Range | 0~65535  | Unit | - | Defaults     | 0 |

When the host cannot automatically assign the servo driver site address, you can manually assign a site address to the driver in this way.  
 0: the site address is not assigned manually. The site address is assigned by the host or written to EEPROM.  
 Other values: manually assign a station address. After the driver is powered on and initialized, the value of p08.08 will be consistent with the set value.  
**Note: this operation is only to write the site alias register of the ESC slave controller chip of EtherCAT. As for whether to actually enable the site address as the addressing address of the servo driver, the host needs to carry out corresponding operations.**

|        |       |                                  |      |   |              |   |
|--------|-------|----------------------------------|------|---|--------------|---|
| P08.30 | Name  | RS232 communication axis address |      |   | Related mode | - |
|        | Range | -                                | Unit | - | Defaults     | 1 |

|        |       |   |      |   |              |   |
|--------|-------|---|------|---|--------------|---|
| P08.31 | Name  | RS232 communication serial port baud rate selection |      |   | Related mode | - |
|        | Range | 0~5   | Unit | - | Defaults     | 5 |

Set the RS232 communication baud rate, please refer to parameter P08.01 (RS485 communication data format selection) for the setting method.

|        |       |   |      |   |              |   |
|--------|-------|---|------|---|--------------|---|
| P08.32 | Name  | RS232 communication data format selection |      |   | Related mode | - |
|        | Range | 0~5                                       | Unit | - | Defaults     | 0 |

Set the RS232 communication data format, please refer to parameter P08.02 (RS485 communication data format selection) for the setting method.

**5.9 Group P09: Multi-segment position parameters**

|        |       |                                     |      |   |              |   |
|--------|-------|-------------------------------------|------|---|--------------|---|
| P09.00 | Name  | Multi-stage position operation mode |      |   | Related mode | P |
|        | Range | 0~2                                 | Unit | - | Defaults     | 1 |

In the position control mode, when the source of the set position command is multi-stage position command (p03.00 = 2), set the multi-stage position operation mode.

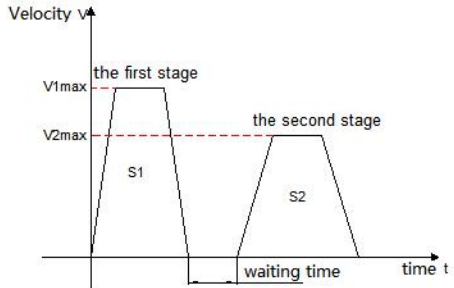
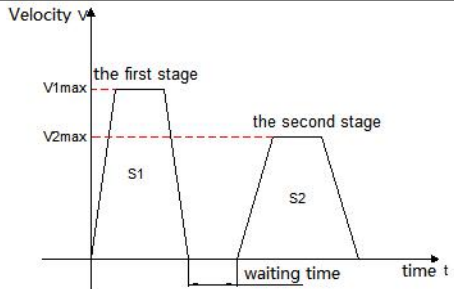
| Set value | Operation mode                            | Remark  | Operating waveform   |
|-----------|---|---|--|
| 0         | Shutdown at the end of a single operation | Stop after running for 1 round;<br>The segment number is automatically switched in increasing order;<br>Waiting time can be set between segments;<br>Multi-segment position enable is level effective;  |  <p>Velocity <math>v</math></p> <p>the first stage</p> <p><math>V_{1max}</math></p> <p><math>V_{2max}</math></p> <p>the second stage</p> <p>S1</p> <p>S2</p> <p>waiting time</p> <p>time <math>t</math></p> <p><math>V_{1max}</math>、<math>V_{2max}</math>: maximum operating speed of the first and second segments;<br/>                     S1、S2: displacement of the first and second segments;</p> |
| 1         | Cyclic operation                          | Cycle operation, the starting segment number after the first round is 1;<br>The segment number is automatically switched in increasing order;<br>Waiting time can be set between segments;<br>Multi-segment position enable is level effective; |  <p>Velocity <math>v</math></p> <p>the first stage</p> <p><math>V_{1max}</math></p> <p><math>V_{2max}</math></p> <p>the second stage</p> <p>S1</p> <p>S2</p> <p>waiting time</p> <p>time <math>t</math></p> <p><math>V_{1max}</math>、<math>V_{2max}</math>: maximum operating speed of the first and second segments;<br/>                     S1、S2: displacement of the first and second segments;</p> |

|   |                        |   |  |
|---|------------------------|---|--|
| 2 | IN switching operation | <p>If the segment number is updated, it can run continuously;</p> <p>The segment number is determined by IN terminal logic;</p> <p>The interval between segments is determined by the command delay time of the host computer;</p> <p>Multi-segment position enable is effective for edge change;</p> | <p>可用于设置 y 段段号的时间区域:Can be used to set the time zone of the y segment number.</p> <p><math>V_{xmax}</math> 、 <math>V_{ymax}</math>: maximum operating speed of the x and y segments;</p> <p><math>S_1</math> 、 <math>S_2</math>: displacement of the x and y segments;</p> |
|---|------------------------|---|--|

|        |       |   |      |   |              |   |
|--------|-------|---|------|---|--------------|---|
| P09.01 | Name  | Number of terminal segments of position command |      |   | Related mode | P |
|        | Range | 1~16  | Unit | - | Defaults     | 1 |

Set the total number of segments of the multi-segment position command. Different segments can set different displacement, running speed, acceleration and deceleration.

When P09.00 = 0/1, the multi-segment segment number will automatically increase and switch, and the switching sequence: 1, 2, 3,..., P09.01

When P09.01 = 2, 4 INs should be set as input functions FunIN.14 ~ FunIN.17 (multi-stage running command switching 1: CMD1 ~ multi-stage running command switching 4: CMD4), and the logic of the IN terminal is controlled by the upper computer to achieve Segment number switching. The multi-segment segment number is a 4-digit binary number, and the corresponding relationship between CMD1 ~ CMD4 and the segment number is shown below.

| FunIN.17<br>CMD4 | FunIN.16<br>CMD3 | FunIN.15<br>CMD2 | FunIN.14<br>CMD1 | segment number |
|------------------|------------------|------------------|------------------|----------------|
| 0                | 0                | 0                | 0                | 1              |
| 0                | 0                | 0                | 1                | 2              |
| .....            |                  |                  |                  |                |
| 1                | 1                | 1                | 0                | 15             |
| 1                | 1                | 1                | 1                | 16             |

The value of CMD(n) is 1 when the IN terminal logic is valid, otherwise it is 0.

|        |       |                     |      |   |              |   |
|--------|-------|---------------------|------|---|--------------|---|
| P09.03 | Name  | Time unit selection |      |   | Related mode | P |
|        | Range | 0~1                 | Unit | - | Defaults     | 0 |

When the multi segment position function is used for operation and p09.00 = 0 / 1 is set, the unit of waiting time between segments is set.

Waiting time: the time interval from the end of this command to the beginning of the next command.

| Set value | Time unit |
|-----------|-----------|
| 0         | ms        |
| 1         | s         |

| P09.04 | Name  | Position command type selection |      |   | Related mode | P |
|--------|-------|---------------------------------|------|---|--------------|---|
|        | Range | 0~1                             | Unit | - | Defaults     | 0 |

When using the multi-segment position function to run, set the type of displacement command.

Displacement command: the sum of position commands in a period of time.

The relative displacement is the increment of the target position relative to the current position of the motor; the absolute displacement is the increment of the target position relative to the motor origin. For example: the movement displacement of the nth segment is  $P_n$  ( $P_n > 0$ ), and the movement displacement of the mth segment is  $P_m$  ( $P_m > 0$ ). Assuming  $P_m > P_n$ , the comparison is as follows:

| Set value | Position command type         | Remark |
|-----------|-------------------------------|--------|
| 0         | Relative displacement command |        |
| 1         | Absolute displacement command |        |

|  |       |                        |      |              |              |       |
|--|-------|------------------------|------|--------------|--------------|-------|
| P09.12<br>P09.13   | Name  | 1st position command   |      |              | Related mode | P     |
|  | Range | -1073741824~1073741824 | Unit | Command unit | Defaults     | 10000 |
| Multi segment position first segment movement displacement (command unit). P09.12 and p09.13 are combined into a 32-bit signed value, where p09.12 is the low 16 bit value and p09.13 is the high 16 bit value. Subsequently, p09.12 is used to represent this 32-bit parameter. |       |                        |      |              |              |       |

|  |       |                             |      |     |              |     |
|--|-------|-----------------------------|------|-----|--------------|-----|
| P09.14   | Name  | 1st maximum operating speed |      |     | Related mode | P   |
|  | Range | 1~6000                      | Unit | rpm | Defaults     | 200 |
| Maximum operating speed of the first segment at multi segment position. The maximum running speed refers to the uniform running speed at which the motor is not in the acceleration and deceleration process. If the 1st position command (p09.12) is too small, the actual speed of the motor will be less than p09.14. |       |                             |      |     |              |     |

|   |       |  |      |    |              |     |
|---|-------|--|------|----|--------------|-----|
| P09.15  | Name  | 1st position command acceleration and deceleration time constant |      |    | Related mode | P   |
|   | Range | 1~65535  | Unit | ms | Defaults     | 100 |
| In the first stage of multi-stage position, the time of the motor from 0rpm uniform speed to 1000rpm. |       |  |      |    |              |     |

|   |       |   |      |       |              |     |
|---|-------|---|------|-------|--------------|-----|
| P09.16  | Name  | Waiting time after the completion of 1st segment position command |      |       | Related mode | P   |
|   | Range | 0~65535   | Unit | ms(s) | Defaults     | 100 |
| After the first stage of the multi-stage position is completed, the waiting time before running the next stage of displacement. |       |   |      |       |              |     |

|                  |       |                       |      |              |              |       |
|------------------|-------|-----------------------|------|--------------|--------------|-------|
| P09.17<br>P09.18 | Name  | 2nd position command  |      |              | Related mode | P     |
|                  | Range | -1073741824~107341824 | Unit | Command unit | Defaults     | 10000 |

|        |       |                             |      |     |              |     |
|--------|-------|-----------------------------|------|-----|--------------|-----|
| P09.19 | Name  | 2nd maximum operating speed |      |     | Related mode | P   |
|        | Range | 1~6000                      | Unit | rpm | Defaults     | 200 |

|        |       |  |      |    |              |     |
|--------|-------|--|------|----|--------------|-----|
| P09.20 | Name  | 2nd position command acceleration and deceleration time constant |      |    | Related mode | P   |
|        | Range | 1~65535  | Unit | ms | Defaults     | 100 |

|        |       |   |      |       |              |     |
|--------|-------|---|------|-------|--------------|-----|
| P09.21 | Name  | Waiting time after the completion of 2nd segment position command |      |       | Related mode | P   |
|        | Range | 0~65535   | Unit | ms(s) | Defaults     | 100 |

|                  |       |                       |      |              |              |       |
|------------------|-------|-----------------------|------|--------------|--------------|-------|
| P09.22<br>P09.23 | Name  | 3rd position command  |      |              | Related mode | P     |
|                  | Range | -1073741824~107341824 | Unit | Command unit | Defaults     | 10000 |

|        |       |                             |      |     |              |     |
|--------|-------|-----------------------------|------|-----|--------------|-----|
| P09.24 | Name  | 3rd maximum operating speed |      |     | Related mode | P   |
|        | Range | 1~6000                      | Unit | rpm | Defaults     | 200 |

|        |       |  |      |    |              |     |
|--------|-------|--|------|----|--------------|-----|
| P09.25 | Name  | 3rd position command acceleration and deceleration time constant |      |    | Related mode | P   |
|        | Range | 1~65535  | Unit | ms | Defaults     | 100 |

|        |       |   |      |       |              |     |
|--------|-------|---|------|-------|--------------|-----|
| P09.26 | Name  | Waiting time after the completion of 3rd segment position command |      |       | Related mode | P   |
|        | Range | 0~65535   | Unit | ms(s) | Defaults     | 100 |

|                  |       |                       |      |              |              |       |
|------------------|-------|-----------------------|------|--------------|--------------|-------|
| P09.27<br>P09.28 | Name  | 4th position command  |      |              | Related mode | P     |
|                  | Range | -1073741824~107341824 | Unit | Command unit | Defaults     | 10000 |

|        |       |                             |      |     |              |     |
|--------|-------|-----------------------------|------|-----|--------------|-----|
| P09.29 | Name  | 4th maximum operating speed |      |     | Related mode | P   |
|        | Range | 1~6000                      | Unit | rpm | Defaults     | 200 |

|        |       |  |      |    |              |     |
|--------|-------|--|------|----|--------------|-----|
| P09.30 | Name  | 4th position command acceleration and deceleration time constant |      |    | Related mode | P   |
|        | Range | 1~65535  | Unit | ms | Defaults     | 100 |

|        |       |   |      |       |              |     |
|--------|-------|---|------|-------|--------------|-----|
| P09.31 | Name  | Waiting time after the completion of 4th segment position command |      |       | Related mode | P   |
|        | Range | 0~65535   | Unit | ms(s) | Defaults     | 100 |

|                  |       |                       |      |              |              |       |
|------------------|-------|-----------------------|------|--------------|--------------|-------|
| P09.32<br>P09.33 | Name  | 5th position command  |      |              | Related mode | P     |
|                  | Range | -1073741824~107341824 | Unit | Command unit | Defaults     | 10000 |

|        |       |                             |      |     |              |     |
|--------|-------|-----------------------------|------|-----|--------------|-----|
| P09.34 | Name  | 5th maximum operating speed |      |     | Related mode | P   |
|        | Range | 1~6000                      | Unit | rpm | Defaults     | 200 |

|        |       |  |      |    |              |     |
|--------|-------|--|------|----|--------------|-----|
| P09.35 | Name  | 5th position command acceleration and deceleration time constant |      |    | Related mode | P   |
|        | Range | 1~65535  | Unit | ms | Defaults     | 100 |

|        |       |   |      |       |              |     |
|--------|-------|---|------|-------|--------------|-----|
| P09.36 | Name  | Waiting time after the completion of 5th segment position command |      |       | Related mode | P   |
|        | Range | 0~65535   | Unit | ms(s) | Defaults     | 100 |

|                  |       |                       |      |              |              |       |
|------------------|-------|-----------------------|------|--------------|--------------|-------|
| P09.37<br>P09.38 | Name  | 6th position command  |      |              | Related mode | P     |
|                  | Range | -1073741824~107341824 | Unit | Command unit | Defaults     | 10000 |

|        |       |  |      |     |              |     |
|--------|-------|--|------|-----|--------------|-----|
| P09.39 | Name  | 6th maximum operating speed                                      |      |     | Related mode | P   |
|        | Range | 1~6000   | Unit | rpm | Defaults     | 200 |
| P09.40 | Name  | 6th position command acceleration and deceleration time constant |      |     | Related mode | P   |
|        | Range | 1~65535  | Unit | ms  | Defaults     | 100 |

|        |       |   |      |       |              |     |
|--------|-------|---|------|-------|--------------|-----|
| P09.41 | Name  | Waiting time after the completion of 6th segment position command |      |       | Related mode | P   |
|        | Range | 0~65535   | Unit | ms(s) | Defaults     | 100 |

|                  |       |                       |      |              |              |       |
|------------------|-------|-----------------------|------|--------------|--------------|-------|
| P09.42<br>P09.43 | Name  | 7th position command  |      |              | Related mode | P     |
|                  | Range | -1073741824~107341824 | Unit | Command unit | Defaults     | 10000 |

|        |       |  |      |     |              |     |
|--------|-------|--|------|-----|--------------|-----|
| P09.44 | Name  | 7th maximum operating speed                                      |      |     | Related mode | P   |
|        | Range | 1~6000   | Unit | rpm | Defaults     | 200 |
| P09.45 | Name  | 7th position command acceleration and deceleration time constant |      |     | Related mode | P   |
|        | Range | 1~65535  | Unit | ms  | Defaults     | 100 |

|        |       |   |      |       |              |     |
|--------|-------|---|------|-------|--------------|-----|
| P09.46 | Name  | Waiting time after the completion of 7th segment position command |      |       | Related mode | P   |
|        | Range | 0~65535   | Unit | ms(s) | Defaults     | 100 |

|                  |       |                       |      |              |              |       |
|------------------|-------|-----------------------|------|--------------|--------------|-------|
| P09.47<br>P09.48 | Name  | 8th position command  |      |              | Related mode | P     |
|                  | Range | -1073741824~107341824 | Unit | Command unit | Defaults     | 10000 |

|        |       |  |      |     |              |     |
|--------|-------|--|------|-----|--------------|-----|
| P09.49 | Name  | 8th maximum operating speed                                      |      |     | Related mode | P   |
|        | Range | 1~6000   | Unit | rpm | Defaults     | 200 |
| P09.50 | Name  | 8th position command acceleration and deceleration time constant |      |     | Related mode | P   |
|        | Range | 1~65535  | Unit | ms  | Defaults     | 100 |

|        |       |   |      |       |              |     |
|--------|-------|---|------|-------|--------------|-----|
| P09.51 | Name  | Waiting time after the completion of 8th segment position command |      |       | Related mode | P   |
|        | Range | 0~65535   | Unit | ms(s) | Defaults     | 100 |

|        |       |                       |      |              |              |       |
|--------|-------|-----------------------|------|--------------|--------------|-------|
| P09.52 | Name  | 9th position command  |      |              | Related mode | P     |
| P09.53 | Range | -1073741824~107341824 | Unit | Command unit | Defaults     | 10000 |

|        |       |                             |      |     |              |     |
|--------|-------|-----------------------------|------|-----|--------------|-----|
| P09.54 | Name  | 9th maximum operating speed |      |     | Related mode | P   |
|        | Range | 1~6000                      | Unit | rpm | Defaults     | 200 |

|        |       |  |      |    |              |     |
|--------|-------|--|------|----|--------------|-----|
| P09.55 | Name  | 9th position command acceleration and deceleration time constant |      |    | Related mode | P   |
|        | Range | 1~65535  | Unit | ms | Defaults     | 100 |

|        |       |   |      |       |              |     |
|--------|-------|---|------|-------|--------------|-----|
| P09.56 | Name  | Waiting time after the completion of 9th segment position command |      |       | Related mode | P   |
|        | Range | 0~65535   | Unit | ms(s) | Defaults     | 100 |

|        |       |                       |      |              |              |       |
|--------|-------|-----------------------|------|--------------|--------------|-------|
| P09.57 | Name  | 10th position command |      |              | Related mode | P     |
| P09.58 | Range | -1073741824~107341824 | Unit | Command unit | Defaults     | 10000 |

|        |       |                              |      |     |              |     |
|--------|-------|------------------------------|------|-----|--------------|-----|
| P09.59 | Name  | 10th maximum operating speed |      |     | Related mode | P   |
|        | Range | 1~6000                       | Unit | rpm | Defaults     | 200 |

|        |       |   |      |    |              |     |
|--------|-------|---|------|----|--------------|-----|
| P09.60 | Name  | 10th position command acceleration and deceleration time constant |      |    | Related mode | P   |
|        | Range | 1~65535   | Unit | ms | Defaults     | 100 |

|        |       |  |      |       |              |     |
|--------|-------|--|------|-------|--------------|-----|
| P09.61 | Name  | Waiting time after the completion of 10th segment position command |      |       | Related mode | P   |
|        | Range | 0~65535  | Unit | ms(s) | Defaults     | 100 |

|        |       |                       |      |              |              |       |
|--------|-------|-----------------------|------|--------------|--------------|-------|
| P09.62 | Name  | 11th position command |      |              | Related mode | P     |
| P09.63 | Range | -1073741824~107341824 | Unit | Command unit | Defaults     | 10000 |

|        |       |                              |      |     |              |     |
|--------|-------|------------------------------|------|-----|--------------|-----|
| P09.64 | Name  | 11th maximum operating speed |      |     | Related mode | P   |
|        | Range | 1~6000                       | Unit | rpm | Defaults     | 200 |

|        |       |   |      |    |              |     |
|--------|-------|---|------|----|--------------|-----|
| P09.65 | Name  | 11th position command acceleration and deceleration time constant |      |    | Related mode | P   |
|        | Range | 1~65535   | Unit | ms | Defaults     | 100 |



|        |       |  |      |       |              |     |
|--------|-------|--|------|-------|--------------|-----|
| P09.66 | Name  | Waiting time after the completion of 11th segment position command |      |       | Related mode | P   |
|        | Range | 0~65535  | Unit | ms(s) | Defaults     | 100 |

|                  |       |                       |      |              |              |       |
|------------------|-------|-----------------------|------|--------------|--------------|-------|
| P09.67<br>P09.68 | Name  | 12th position command |      |              | Related mode | P     |
|                  | Range | -1073741824~107341824 | Unit | Command unit | Defaults     | 10000 |

|        |       |                              |      |     |              |     |
|--------|-------|------------------------------|------|-----|--------------|-----|
| P09.69 | Name  | 12th maximum operating speed |      |     | Related mode | P   |
|        | Range | 1~6000                       | Unit | rpm | Defaults     | 200 |

|        |       |   |      |    |              |     |
|--------|-------|---|------|----|--------------|-----|
| P09.70 | Name  | 12th position command acceleration and deceleration time constant |      |    | Related mode | P   |
|        | Range | 1~65535   | Unit | ms | Defaults     | 100 |

|        |       |  |      |       |              |     |
|--------|-------|--|------|-------|--------------|-----|
| P09.71 | Name  | Waiting time after the completion of 12th segment position command |      |       | Related mode | P   |
|        | Range | 0~65535  | Unit | ms(s) | Defaults     | 100 |

|                  |       |                       |      |              |              |       |
|------------------|-------|-----------------------|------|--------------|--------------|-------|
| P09.72<br>P09.73 | Name  | 13th position command |      |              | Related mode | P     |
|                  | Range | -1073741824~107341824 | Unit | Command unit | Defaults     | 10000 |

|        |       |                              |      |     |              |     |
|--------|-------|------------------------------|------|-----|--------------|-----|
| P09.74 | Name  | 13th maximum operating speed |      |     | Related mode | P   |
|        | Range | 1~6000                       | Unit | rpm | Defaults     | 200 |

|        |       |   |      |    |              |     |
|--------|-------|---|------|----|--------------|-----|
| P09.75 | Name  | 13th position command acceleration and deceleration time constant |      |    | Related mode | P   |
|        | Range | 1~65535   | Unit | ms | Defaults     | 100 |

|        |       |  |      |       |              |     |
|--------|-------|--|------|-------|--------------|-----|
| P09.76 | Name  | Waiting time after the completion of 13th segment position command |      |       | Related mode | P   |
|        | Range | 0~65535  | Unit | ms(s) | Defaults     | 100 |

|                  |       |                       |      |              |              |       |
|------------------|-------|-----------------------|------|--------------|--------------|-------|
| P09.77<br>P09.78 | Name  | 14th position command |      |              | Related mode | P     |
|                  | Range | -1073741824~107341824 | Unit | Command unit | Defaults     | 10000 |

|        |       |                              |      |     |              |     |
|--------|-------|------------------------------|------|-----|--------------|-----|
| P09.79 | Name  | 14th maximum operating speed |      |     | Related mode | P   |
|        | Range | 1~6000                       | Unit | rpm | Defaults     | 200 |

|        |      |   |  |  |              |   |
|--------|------|---|--|--|--------------|---|
| P09.80 | Name | 14th position command acceleration and deceleration time constant |  |  | Related mode | P |
|--------|------|---|--|--|--------------|---|

|                  |       |  |      |              |              |       |
|------------------|-------|--|------|--------------|--------------|-------|
|                  | Range | 1~65535  | Unit | ms           | Defaults     | 100   |
| P09.81           | Name  | Waiting time after the completion of 14th segment position command |      |              | Related mode | P     |
|                  | Range | 0~65535  | Unit | ms(s)        | Defaults     | 100   |
| P09.82<br>P09.83 | Name  | 15th position command  |      |              | Related mode | P     |
|                  | Range | -1073741824~107341824  | Unit | Command unit | Defaults     | 10000 |
| P09.84           | Name  | 15th maximum operating speed                                       |      |              | Related mode | P     |
|                  | Range | 1~6000   | Unit | rpm          | Defaults     | 200   |
| P09.85           | Name  | 15th position command acceleration and deceleration time constant  |      |              | Related mode | P     |
|                  | Range | 1~65535  | Unit | ms           | Defaults     | 100   |
| P09.86           | Name  | Waiting time after the completion of 15th segment position command |      |              | Related mode | P     |
|                  | Range | 0~65535  | Unit | ms(s)        | Defaults     | 100   |
| P09.87<br>P09.88 | Name  | 16th position command  |      |              | Related mode | P     |
|                  | Range | -1073741824~107341824  | Unit | Command unit | Defaults     | 10000 |
| P09.89           | Name  | 16th maximum operating speed                                       |      |              | Related mode | P     |
|                  | Range | 1~6000   | Unit | rpm          | Defaults     | 200   |
| P09.90           | Name  | 16th position command acceleration and deceleration time constant  |      |              | Related mode | P     |
|                  | Range | 1~65535  | Unit | ms           | Defaults     | 100   |
| P09.91           | Name  | Waiting time after the completion of 16th segment position command |      |              | Related mode | P     |
|                  | Range | 0~65535  | Unit | ms(s)        | Defaults     | 100   |

**5.10 Group P10: Multi-segment speed parameters**

|        |       |  |      |   |              |   |
|--------|-------|--|------|---|--------------|---|
| P10.00 | Name  | Multi-segment speed command operation mode |      |   | Related mode | S |
|        | Range | 0~2  | Unit | - | Defaults     | 1 |

In speed control mode, when the speed command source is a multi-segment speed command (P04.00=1), set the multi-segment speed command operation mode:

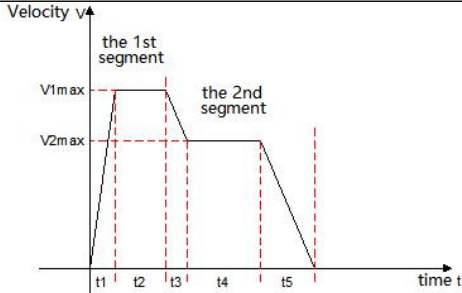
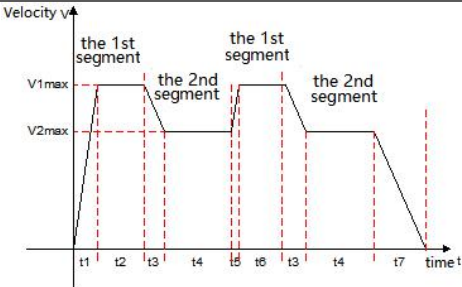
| Set value | Operation mode                            | Remark  | Operating waveform   |
|-----------|---|---|--|
| 0         | Shutdown at the end of a single operation | Stop after running for 1 round;<br>The segment number is automatically switched in increasing order.  |  <p>V1max, V2max: the first and second command speeds;<br/>                     t1: the actual acceleration and deceleration time of the first segment;<br/>                     t3, t5: the second segment of acceleration and deceleration time.</p> |
| 1         | Cyclic operation                          | Cycle operation, the starting segment number of each round is 1;<br>the segment number is automatically switched in increasing order;<br>If the servo enable is valid, the cycle running state will always be maintained. |  <p>V1max、V2max : the first and second segment maximum operating speeds.</p>  |

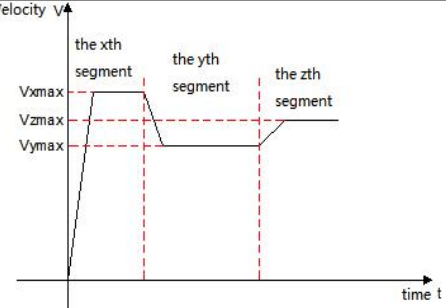
|   |                                     |  |   |
|---|-------------------------------------|--|---|
| 2 | Switch through the external IN port | <p>If the servo is enabled, it can run continuously;<br/>                 The segment number is determined by the IN terminal logic;<br/>                 The running time of each speed command is only determined by the switching interval time of the segment number;<br/>                 FunIN.19 (speed command direction setting) can be used to switch the speed command direction.</p> |  <p>x, y: segment number, please refer to P10.01 for the logical relationship between segment number and IN terminal;<br/>                 Vx, Vy: the speed command of the xth section and the yth section;<br/>                 The segment number determined by IN will not change, and the speed command of this segment will continue to run without being affected by the command running time.</p> |
|---|-------------------------------------|--|---|

During the operation of each speed command, the servo enable must be ensured, otherwise, the servo driver will stop.

|        |       |                                  |      |   |              |    |
|--------|-------|----------------------------------|------|---|--------------|----|
| P10.01 | Name  | Speed command end segment number |      |   | Related mode | S  |
|        | Range | 1~16                             | Unit | - | Defaults     | 16 |

Set the total number of segments of the speed command. Different segments can set different speeds and running times, and there are 7 groups of acceleration and deceleration times for selection.

When P10.00≠2, the multi-segment segment numbers are automatically switched in increasing order, the switching sequence: 1, 2, ..., P10.01.

When P10.00=2, 4 INs should be set as IN functions 14~17 (FunIN.14~FunIN.17), and the upper computer controls the IN logic to realize the segment number switching. The multi-segment segment number is a 4-digit binary number. The corresponding relationship between FunIN.14~FunIN.17 and the segment number is shown in the following table.

| FunIN.17 | FunIN.16 | FunIN.15 | FunIN.14 | Segment number |
|----------|----------|----------|----------|----------------|
| 0        | 0        | 0        | 0        | 1              |
| 0        | 0        | 0        | 1        | 2              |
| 0        | 0        | 1        | 0        | 3              |
| .....    |          |          |          |                |
| 1        | 1        | 1        | 1        | 16             |

When the IN terminal logic is valid, the value of FunIN.n is 1, otherwise it is 0.

|  |       |                   |             |   |              |   |
|--|-------|-------------------|-------------|---|--------------|---|
| P10.02                                     | Name  | Running time unit |             |   | Related mode | S |
|  | Range | 0~65535           | Unit        | - | Defaults     | 0 |
| Set multi-segment speed running time unit. |       |                   |             |   |              |   |
|  |       | Set value         | Time unit   |   |              |   |
|  |       | 0                 | sec(second) |   |              |   |
|  |       | 1                 | min(minute) |   |              |   |

|   |       |                              |      |    |              |     |
|---|-------|------------------------------|------|----|--------------|-----|
| P10.03  | Name  | Acceleration time constant 1 |      |    | Related mode | S   |
|   | Range | 1~65535                      | Unit | ms | Defaults     | 200 |
| For each multi-stage speed command, there are 7 groups of acceleration and deceleration time constants for selection. |       |                              |      |    |              |     |
| Acceleration time constant: the time for the servo motor to uniformly accelerate from 0rpm to 1000rpm.                |       |                              |      |    |              |     |
| Deceleration time constant: the time for the servo motor to decelerate uniformly from 1000rpm to 0rpm.                |       |                              |      |    |              |     |

|        |       |                              |      |    |              |     |
|--------|-------|------------------------------|------|----|--------------|-----|
| P10.04 | Name  | Deceleration time constant 1 |      |    | Related mode | S   |
|        | Range | 1~65535                      | Unit | ms | Defaults     | 200 |

|        |       |                              |      |    |              |     |
|--------|-------|------------------------------|------|----|--------------|-----|
| P10.05 | Name  | Acceleration time constant 2 |      |    | Related mode | S   |
|        | Range | 1~65535                      | Unit | ms | Defaults     | 200 |

|        |       |                              |      |    |              |     |
|--------|-------|------------------------------|------|----|--------------|-----|
| P10.06 | Name  | Deceleration time constant 2 |      |    | Related mode | S   |
|        | Range | 1~65535                      | Unit | ms | Defaults     | 200 |

|        |       |                              |      |    |              |     |
|--------|-------|------------------------------|------|----|--------------|-----|
| P10.07 | Name  | Acceleration time constant 3 |      |    | Related mode | S   |
|        | Range | 1~65535                      | Unit | ms | Defaults     | 200 |

|        |       |                              |      |    |              |     |
|--------|-------|------------------------------|------|----|--------------|-----|
| P10.08 | Name  | Deceleration time constant 3 |      |    | Related mode | S   |
|        | Range | 1~65535                      | Unit | ms | Defaults     | 200 |

|        |       |                              |      |    |              |     |
|--------|-------|------------------------------|------|----|--------------|-----|
| P10.09 | Name  | Acceleration time constant 4 |      |    | Related mode | S   |
|        | Range | 1~65535                      | Unit | ms | Defaults     | 200 |

|        |       |                              |      |    |              |     |
|--------|-------|------------------------------|------|----|--------------|-----|
| P10.10 | Name  | Deceleration time constant 4 |      |    | Related mode | S   |
|        | Range | 1~65535                      | Unit | ms | Defaults     | 200 |

|        |       |                              |      |    |              |     |
|--------|-------|------------------------------|------|----|--------------|-----|
| P10.11 | Name  | Acceleration time constant 5 |      |    | Related mode | S   |
|        | Range | 1~65535                      | Unit | ms | Defaults     | 200 |

|        |       |                              |      |    |              |     |
|--------|-------|------------------------------|------|----|--------------|-----|
| P10.12 | Name  | Deceleration time constant 5 |      |    | Related mode | S   |
|        | Range | 1~65535                      | Unit | ms | Defaults     | 200 |

|        |       |                              |      |    |              |     |
|--------|-------|------------------------------|------|----|--------------|-----|
| P10.13 | Name  | Acceleration time constant 6 |      |    | Related mode | S   |
|        | Range | 1~65535                      | Unit | ms | Defaults     | 200 |

|        |       |                              |      |    |              |     |
|--------|-------|------------------------------|------|----|--------------|-----|
| P10.14 | Name  | Deceleration time constant 6 |      |    | Related mode | S   |
|        | Range | 1~65535                      | Unit | ms | Defaults     | 200 |

|        |       |                              |      |    |              |     |
|--------|-------|------------------------------|------|----|--------------|-----|
| P10.15 | Name  | Acceleration time constant 7 |      |    | Related mode | S   |
|        | Range | 1~65535                      | Unit | ms | Defaults     | 200 |

|        |       |                              |      |    |              |     |
|--------|-------|------------------------------|------|----|--------------|-----|
| P10.16 | Name  | Deceleration time constant 7 |      |    | Related mode | S   |
|        | Range | 1~65535                      | Unit | ms | Defaults     | 200 |

|        |       |                           |      |     |              |     |
|--------|-------|---------------------------|------|-----|--------------|-----|
| P10.20 | Name  | 1st segment speed command |      |     | Related mode | S   |
|        | Range | -6000~6000                | Unit | rpm | Defaults     | 100 |

|        |       |  |      |               |              |    |
|--------|-------|--|------|---------------|--------------|----|
| P10.21 | Name  | 1st segment speed command running time |      |               | Related mode | S  |
|        | Range | 0~65535                                | Unit | 0.1sec/0.1min | Defaults     | 10 |

Set the running time of the first segment speed command.  
 Running time: the shifting time of the previous speed command switching to this speed command + this constant speed running time.  
 If the running time is set to 0, the servo driver will automatically skip this speed command.  
 When P10.02=2, as long as the segment number determined by the external IN terminal does not change, the speed command of this segment will continue to run without being affected by the command running time.

|        |       |   |      |   |              |   |
|--------|-------|---|------|---|--------------|---|
| P10.22 | Name  | 1st segment acceleration and deceleration time constant selection |      |   | Related mode | S |
|        | Range | 1~7   | Unit | - | Defaults     | 1 |

Select the acceleration and deceleration time constant of the first segment speed command.

| Set value | Acceleration and deceleration time constant   | Remark   |
|-----------|---|--|
| 1         | Acceleration and deceleration time constant 1 | Acceleration time: P10.03<br>Deceleration time: P10.04 |
| 2         | Acceleration and deceleration time constant 2 | Acceleration time: P10.05<br>Deceleration time: P10.06 |
| 3         | Acceleration and deceleration time constant 3 | Acceleration time: P10.07<br>Deceleration time: P10.08 |
| 4         | Acceleration and deceleration time constant 4 | Acceleration time: P10.09<br>Deceleration time: P10.10 |
| 5         | Acceleration and deceleration time constant 5 | Acceleration time: P10.11<br>Deceleration time: P10.12 |
| 6         | Acceleration and deceleration time constant 6 | Acceleration time: P10.13<br>Deceleration time: P10.14 |
| 7         | Acceleration and deceleration time constant 7 | Acceleration time: P10.15<br>Deceleration time: P10.16 |

V1max, V2max: the first and second segment command speeds;

t1: the actual acceleration and deceleration time of the first segment;

t3、 t5: the actual acceleration and deceleration time of the second segment;

A certain period of running time: the shifting time of the previous speed command switching to this speed command + the constant speed running time of this section (for example: the running time of the first segment in the figure is t1+t2, and the running time of the second segment is t3+t4. And so on);

When a certain period of running time is set to 0, the driver will skip this section of speed command and execute the next section;

$$t_1 = \frac{V_1}{1000} \times \text{Acceleration time set for this speed segment}$$

$$t_3 = \frac{|V_2 - V_1|}{1000} \times \text{The acceleration time set in the second segment}$$

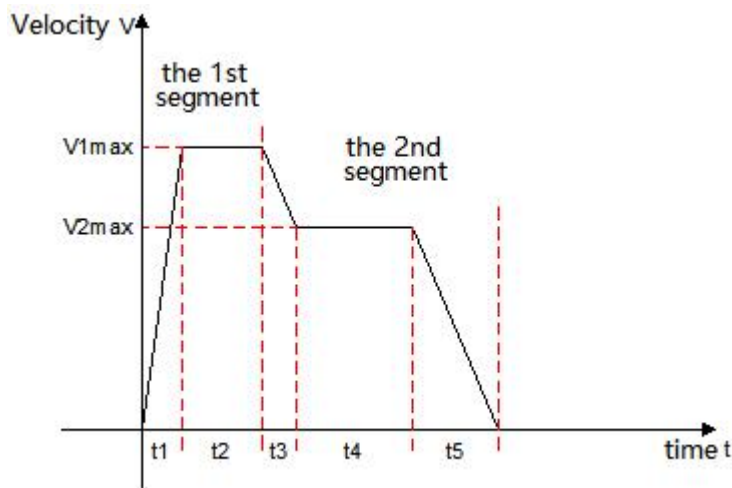

|        |       |                           |      |              |                 |
|--------|-------|---------------------------|------|--------------|-----------------|
| P10.23 | Name  | 2nd segment speed command |      | Related mode | S               |
|        | Range | -6000~6000                | Unit | rpm          | Defaults<br>200 |

|        |       |   |      |               |              |    |
|--------|-------|---|------|---------------|--------------|----|
| P10.24 | Name  | 2nd segment speed command running time                            |      |               | Related mode | S  |
|        | Range | 0~65535   | Unit | 0.1sec/0.1min | Defaults     | 20 |
| P10.25 | Name  | 2nd segment acceleration and deceleration time constant selection |      |               | Related mode | S  |
|        | Range | 1~7   | Unit | -             | Defaults     | 1  |

|        |       |                           |      |     |              |     |
|--------|-------|---------------------------|------|-----|--------------|-----|
| P10.26 | Name  | 3rd segment speed command |      |     | Related mode | S   |
|        | Range | -6000~6000                | Unit | rpm | Defaults     | 300 |

|        |       |   |      |               |              |    |
|--------|-------|---|------|---------------|--------------|----|
| P10.27 | Name  | 3rd segment speed command running time                            |      |               | Related mode | S  |
|        | Range | 0~65535   | Unit | 0.1sec/0.1min | Defaults     | 30 |
| P10.28 | Name  | 3rd segment acceleration and deceleration time constant selection |      |               | Related mode | S  |
|        | Range | 1~7   | Unit | -             | Defaults     | 1  |

|        |       |                           |      |     |              |     |
|--------|-------|---------------------------|------|-----|--------------|-----|
| P10.29 | Name  | 4th segment speed command |      |     | Related mode | S   |
|        | Range | -6000~6000                | Unit | rpm | Defaults     | 400 |

|        |       |   |      |               |              |    |
|--------|-------|---|------|---------------|--------------|----|
| P10.30 | Name  | 4th segment speed command running time                            |      |               | Related mode | S  |
|        | Range | 0~65535   | Unit | 0.1sec/0.1min | Defaults     | 40 |
| P10.31 | Name  | 4th segment acceleration and deceleration time constant selection |      |               | Related mode | S  |
|        | Range | 1~7   | Unit | -             | Defaults     | 1  |

|        |       |                           |      |     |              |     |
|--------|-------|---------------------------|------|-----|--------------|-----|
| P10.32 | Name  | 5th segment speed command |      |     | Related mode | S   |
|        | Range | -6000~6000                | Unit | rpm | Defaults     | 500 |

|        |       |   |      |               |              |    |
|--------|-------|---|------|---------------|--------------|----|
| P10.33 | Name  | 5th segment speed command running time                            |      |               | Related mode | S  |
|        | Range | 0~65535   | Unit | 0.1sec/0.1min | Defaults     | 50 |
| P10.34 | Name  | 5th segment acceleration and deceleration time constant selection |      |               | Related mode | S  |
|        | Range | 1~7   | Unit | -             | Defaults     | 1  |

|        |       |                           |      |     |              |     |
|--------|-------|---------------------------|------|-----|--------------|-----|
| P10.35 | Name  | 6th segment speed command |      |     | Related mode | S   |
|        | Range | -6000~6000                | Unit | rpm | Defaults     | 600 |



|        |       |   |      |               |              |     |
|--------|-------|---|------|---------------|--------------|-----|
| P10.36 | Name  | 6th segment speed command running time                            |      |               | Related mode | S   |
|        | Range | 0~65535   | Unit | 0.1sec/0.1min | Defaults     | 60  |
| P10.37 | Name  | 6th segment acceleration and deceleration time constant selection |      |               | Related mode | S   |
|        | Range | 1~7   | Unit | -             | Defaults     | 1   |
| P10.38 | Name  | 7th segment speed command   |      |               | Related mode | S   |
|        | Range | -6000~6000  | Unit | rpm           | Defaults     | 700 |
| P10.39 | Name  | 7th segment speed command running time                            |      |               | Related mode | S   |
|        | Range | 0~65535   | Unit | 0.1sec/0.1min | Defaults     | 70  |
| P10.40 | Name  | 7th segment acceleration and deceleration time constant selection |      |               | Related mode | S   |
|        | Range | 1~7   | Unit | -             | Defaults     | 1   |
| P10.41 | Name  | 8th segment speed command   |      |               | Related mode | S   |
|        | Range | -6000~6000  | Unit | rpm           | Defaults     | 800 |
| P10.42 | Name  | 8th segment speed command running time                            |      |               | Related mode | S   |
|        | Range | 0~65535   | Unit | 0.1sec/0.1min | Defaults     | 80  |
| P10.43 | Name  | 8th segment acceleration and deceleration time constant selection |      |               | Related mode | S   |
|        | Range | 1~7   | Unit | -             | Defaults     | 1   |
| P10.44 | Name  | 9th segment speed command   |      |               | Related mode | S   |
|        | Range | -6000~6000  | Unit | rpm           | Defaults     | 900 |
| P10.45 | Name  | 9th segment speed command running time                            |      |               | Related mode | S   |
|        | Range | 0~65535   | Unit | 0.1sec/0.1min | Defaults     | 90  |
| P10.46 | Name  | 9th segment acceleration and deceleration time constant selection |      |               | Related mode | S   |
|        | Range | 1~7   | Unit | -             | Defaults     | 1   |

|        |       |                            |      |     |              |      |
|--------|-------|----------------------------|------|-----|--------------|------|
| P10.47 | Name  | 10th segment speed command |      |     | Related mode | S    |
|        | Range | -6000~6000                 | Unit | rpm | Defaults     | 1000 |

|        |       |  |      |               |              |     |
|--------|-------|--|------|---------------|--------------|-----|
| P10.48 | Name  | 10th segment speed command running time                            |      |               | Related mode | S   |
|        | Range | 0~65535  | Unit | 0.1sec/0.1min | Defaults     | 100 |
| P10.49 | Name  | 10th segment acceleration and deceleration time constant selection |      |               | Related mode | S   |
|        | Range | 1~7  | Unit | -             | Defaults     | 1   |

|        |       |                            |      |     |              |      |
|--------|-------|----------------------------|------|-----|--------------|------|
| P10.50 | Name  | 11th segment speed command |      |     | Related mode | S    |
|        | Range | -6000~6000                 | Unit | rpm | Defaults     | 1100 |

|        |       |  |      |               |              |     |
|--------|-------|--|------|---------------|--------------|-----|
| P10.51 | Name  | 11th segment speed command running time                            |      |               | Related mode | S   |
|        | Range | 0~65535  | Unit | 0.1sec/0.1min | Defaults     | 110 |
| P10.52 | Name  | 11th segment acceleration and deceleration time constant selection |      |               | Related mode | S   |
|        | Range | 1~7  | Unit | -             | Defaults     | 1   |

|        |       |                            |      |     |              |      |
|--------|-------|----------------------------|------|-----|--------------|------|
| P10.53 | Name  | 12th segment speed command |      |     | Related mode | S    |
|        | Range | -6000~6000                 | Unit | rpm | Defaults     | 1200 |

|        |       |  |      |               |              |     |
|--------|-------|--|------|---------------|--------------|-----|
| P10.54 | Name  | 12th segment speed command running time                            |      |               | Related mode | S   |
|        | Range | 0~65535  | Unit | 0.1sec/0.1min | Defaults     | 120 |
| P10.55 | Name  | 12th segment acceleration and deceleration time constant selection |      |               | Related mode | S   |
|        | Range | 1~7  | Unit | -             | Defaults     | 1   |

|        |       |                            |      |     |              |      |
|--------|-------|----------------------------|------|-----|--------------|------|
| P10.56 | Name  | 13th segment speed command |      |     | Related mode | S    |
|        | Range | -6000~6000                 | Unit | rpm | Defaults     | 1300 |

|        |       |  |      |               |              |     |
|--------|-------|--|------|---------------|--------------|-----|
| P10.57 | Name  | 13th segment speed command running time                            |      |               | Related mode | S   |
|        | Range | 0~65535  | Unit | 0.1sec/0.1min | Defaults     | 130 |
| P10.58 | Name  | 13th segment acceleration and deceleration time constant selection |      |               | Related mode | S   |
|        | Range | 1~7  | Unit | -             | Defaults     | 1   |

|        |       |                            |      |     |              |      |
|--------|-------|----------------------------|------|-----|--------------|------|
| P10.59 | Name  | 14th segment speed command |      |     | Related mode | S    |
|        | Range | -6000~6000                 | Unit | rpm | Defaults     | 1400 |

|        |       |   |      |               |              |     |
|--------|-------|---|------|---------------|--------------|-----|
| P10.60 | Name  | 14th segment speed command running time |      |               | Related mode | S   |
|        | Range | 0~65535                                 | Unit | 0.1sec/0.1min | Defaults     | 140 |

|        |       |  |      |   |              |   |
|--------|-------|--|------|---|--------------|---|
| P10.61 | Name  | 14th segment acceleration and deceleration time constant selection |      |   | Related mode | S |
|        | Range | 1~7  | Unit | - | Defaults     | 1 |

|        |       |                            |      |     |              |      |
|--------|-------|----------------------------|------|-----|--------------|------|
| P10.62 | Name  | 15th segment speed command |      |     | Related mode | S    |
|        | Range | -6000~6000                 | Unit | rpm | Defaults     | 1500 |

|        |       |   |      |               |              |     |
|--------|-------|---|------|---------------|--------------|-----|
| P10.63 | Name  | 15th segment speed command running time |      |               | Related mode | S   |
|        | Range | 0~65535                                 | Unit | 0.1sec/0.1min | Defaults     | 150 |

|        |       |  |      |   |              |   |
|--------|-------|--|------|---|--------------|---|
| P10.64 | Name  | 15th segment acceleration and deceleration time constant selection |      |   | Related mode | S |
|        | Range | 1~7  | Unit | - | Defaults     | 1 |

|        |       |                            |      |     |              |      |
|--------|-------|----------------------------|------|-----|--------------|------|
| P10.65 | Name  | 16th segment speed command |      |     | Related mode | S    |
|        | Range | -6000~6000                 | Unit | rpm | Defaults     | 1600 |

|        |       |   |      |               |              |     |
|--------|-------|---|------|---------------|--------------|-----|
| P10.66 | Name  | 16th segment speed command running time |      |               | Related mode | S   |
|        | Range | 0~65535                                 | Unit | 0.1sec/0.1min | Defaults     | 160 |

|        |       |  |      |   |              |   |
|--------|-------|--|------|---|--------------|---|
| P10.67 | Name  | 16th segment acceleration and deceleration time constant selection |      |   | Related mode | S |
|        | Range | 1~7  | Unit | - | Defaults     | 1 |

**5.11 Group P11: Auxiliary display**

The following parameters are used to display the CiA402-related objects in CANopen and EtherCAT bus mode, which is convenient for viewing object values and troubleshooting.

|        |       |                     |      |   |              |   |
|--------|-------|---------------------|------|---|--------------|---|
| P11.00 | Name  | 0x603F (Error code) |      |   | Related mode | - |
|        | Range | -                   | Unit | - | Defaults     | - |

|        |       |                       |      |   |              |   |
|--------|-------|-----------------------|------|---|--------------|---|
| P11.01 | Name  | 0x6040 (Control word) |      |   | Related mode | - |
|        | Range | -                     | Unit | - | Defaults     | - |

|                  |       |  |      |              |              |   |
|------------------|-------|--|------|--------------|--------------|---|
| P11.02           | Name  | 0x6041 (Status word)                             |      |              | Related mode | - |
|                  | Range | -  | Unit | -            | Defaults     | - |
| P11.03           | Name  | 0x605A (Quick stop mode selection)               |      |              | Related mode | - |
|                  | Range | -  | Unit | -            | Defaults     | - |
| P11.04           | Name  | 0x605B (Shutdown mode selection)                 |      |              | Related mode | - |
|                  | Range | -  | Unit | -            | Defaults     | - |
| P11.05           | Name  | 0x605C (Prohibition of operation mode selection) |      |              | Related mode | - |
|                  | Range | -  | Unit | -            | Defaults     | - |
| P11.06           | Name  | 0x605E (Fault shutdown mode selection)           |      |              | Related mode | - |
|                  | Range | -  | Unit | -            | Defaults     | - |
| P11.07           | Name  | 0x6060 (Mode selection)                          |      |              | Related mode | - |
|                  | Range | -  | Unit | -            | Defaults     | - |
| P11.08           | Name  | 0x6061 (Operating mode display)                  |      |              | Related mode | - |
|                  | Range | -  | Unit | -            | Defaults     | - |
| P11.09<br>P11.10 | Name  | 0x6062 (Position command)                        |      |              | Related mode | - |
|                  | Range | -  | Unit | Command unit | Defaults     | - |
| P11.11<br>P11.12 | Name  | 0x6063 (Position feedback)                       |      |              | Related mode | - |
|                  | Range | -  | Unit | Encoder unit | Defaults     | - |
| P11.13<br>P11.14 | Name  | 0x6064 (Position feedback)                       |      |              | Related mode | - |
|                  | Range | -  | Unit | Command unit | Defaults     | - |
| P11.15<br>P11.16 | Name  | 0x6065 (Excessive position deviation threshold)  |      |              | Related mode | - |
|                  | Range | -  | Unit | Command unit | Defaults     | - |
| P11.17           | Name  | 0x6066 (Position deviation time window)          |      |              | Related mode | - |
|                  | Range | -  | Unit | ms           | Defaults     | - |

|                  |       |                                     |      |   |              |   |
|------------------|-------|-------------------------------------|------|---|--------------|---|
| P11.18<br>P11.19 | Name  | 0x6067 (Position reaches threshold) |      |   | Related mode | - |
|                  | Range | -                                   | Unit | - | Defaults     | - |

|        |       |                                       |      |    |              |   |
|--------|-------|---------------------------------------|------|----|--------------|---|
| P11.20 | Name  | 0x6068 (Position reaches time window) |      |    | Related mode | - |
|        | Range | -                                     | Unit | ms | Defaults     | - |

|                  |       |                         |      |                |              |   |
|------------------|-------|-------------------------|------|----------------|--------------|---|
| P11.21<br>P11.22 | Name  | 0x606C (Speed feedback) |      |                | Related mode | - |
|                  | Range | -                       | Unit | Command unit/s | Defaults     | - |

|        |       |                                  |      |     |              |   |
|--------|-------|----------------------------------|------|-----|--------------|---|
| P11.23 | Name  | 0x606D (Speed reaches threshold) |      |     | Related mode | - |
|        | Range | -                                | Unit | rpm | Defaults     | - |

|        |       |                                    |      |    |              |   |
|--------|-------|------------------------------------|------|----|--------------|---|
| P11.24 | Name  | 0x606E (Speed reaches time window) |      |    | Related mode | - |
|        | Range | -                                  | Unit | ms | Defaults     | - |

|        |       |                        |      |      |              |   |
|--------|-------|------------------------|------|------|--------------|---|
| P11.25 | Name  | 0x6071 (Target torque) |      |      | Related mode | - |
|        | Range | -                      | Unit | 0.1% | Defaults     | - |

|        |       |                         |      |      |              |   |
|--------|-------|-------------------------|------|------|--------------|---|
| P11.26 | Name  | 0x6072 (Maximum torque) |      |      | Related mode | - |
|        | Range | -                       | Unit | 0.1% | Defaults     | - |

|        |       |                          |      |      |              |   |
|--------|-------|--------------------------|------|------|--------------|---|
| P11.27 | Name  | 0x6073 (Maximum current) |      |      | Related mode | - |
|        | Range | -                        | Unit | 0.1% | Defaults     | - |

|        |       |                                 |      |      |              |   |
|--------|-------|---------------------------------|------|------|--------------|---|
| P11.28 | Name  | 0x6074 (Internal target torque) |      |      | Related mode | - |
|        | Range | -                               | Unit | 0.1% | Defaults     | - |

|        |       |                          |      |      |              |   |
|--------|-------|--------------------------|------|------|--------------|---|
| P11.29 | Name  | 0x6077 (Torque feedback) |      |      | Related mode | - |
|        | Range | -                        | Unit | 0.1% | Defaults     | - |

|                  |       |                          |      |              |              |   |
|------------------|-------|--------------------------|------|--------------|--------------|---|
| P11.30<br>P11.31 | Name  | 0x607A (Target position) |      |              | Related mode | - |
|                  | Range | -                        | Unit | Command unit | Defaults     | - |

|                  |       |                        |      |              |              |   |
|------------------|-------|------------------------|------|--------------|--------------|---|
| P11.32<br>P11.33 | Name  | 0x607C (Origin offset) |      |              | Related mode | - |
|                  | Range | -                      | Unit | Command unit | Defaults     | - |

|                  |       |   |      |              |              |   |
|------------------|-------|---|------|--------------|--------------|---|
| P11.34<br>P11.35 | Name  | 0x607D_1 (Minimum software absolute position limit) |      |              | Related mode | - |
|                  | Range | -   | Unit | Command unit | Defaults     | - |

|                  |       |   |      |              |              |   |
|------------------|-------|---|------|--------------|--------------|---|
| P11.36<br>P11.37 | Name  | 0x607D_2 (Maximum software absolute position limit) |      |              | Related mode | - |
|                  | Range | -   | Unit | Command unit | Defaults     | - |

|        |       |                           |      |   |              |   |
|--------|-------|---------------------------|------|---|--------------|---|
| P11.38 | Name  | 0x607E (Command polarity) |      |   | Related mode | - |
|        | Range | -                         | Unit | - | Defaults     | - |

|                  |       |                                |      |                |              |   |
|------------------|-------|--------------------------------|------|----------------|--------------|---|
| P11.39<br>P11.40 | Name  | 0x607F (Maximum contour speed) |      |                | Related mode | - |
|                  | Range | -                              | Unit | Command unit/s | Defaults     | - |

|                  |       |                        |      |                |              |   |
|------------------|-------|------------------------|------|----------------|--------------|---|
| P11.41<br>P11.42 | Name  | 0x6081 (Contour speed) |      |                | Related mode | - |
|                  | Range | -                      | Unit | Command unit/s | Defaults     | - |

|                  |       |                               |      |                             |              |   |
|------------------|-------|-------------------------------|------|-----------------------------|--------------|---|
| P11.43<br>P11.44 | Name  | 0x6083 (Contour acceleration) |      |                             | Related mode | - |
|                  | Range | -                             | Unit | Command unit/s <sup>2</sup> | Defaults     | - |

|                  |       |                               |      |                             |              |   |
|------------------|-------|-------------------------------|------|-----------------------------|--------------|---|
| P11.45<br>P11.46 | Name  | 0x6084 (Contour deceleration) |      |                             | Related mode | - |
|                  | Range | -                             | Unit | Command unit/s <sup>2</sup> | Defaults     | - |

|                  |       |                                  |      |                             |              |   |
|------------------|-------|----------------------------------|------|-----------------------------|--------------|---|
| P11.47<br>P11.48 | Name  | 0x6085 (Quick stop deceleration) |      |                             | Related mode | - |
|                  | Range | -                                | Unit | Command unit/s <sup>2</sup> | Defaults     | - |

|                  |       |                       |      |        |              |   |
|------------------|-------|-----------------------|------|--------|--------------|---|
| P11.49<br>P11.50 | Name  | 0x6087 (Torque slope) |      |        | Related mode | - |
|                  | Range | -                     | Unit | 0.1%/s | Defaults     | - |

|                  |       |  |      |   |              |   |
|------------------|-------|--|------|---|--------------|---|
| P11.51<br>P11.52 | Name  | 0x6091_1 (Gear ratio molecular/Motor resolution) |      |   | Related mode | - |
|                  | Range | -  | Unit | - | Defaults     | - |

|                  |       |  |      |   |              |   |
|------------------|-------|--|------|---|--------------|---|
| P11.53<br>P11.54 | Name  | 0x6091_2 (Gear ratio denominator/shaft resolution) |      |   | Related mode | - |
|                  | Range | -  | Unit | - | Defaults     | - |

|        |       |                        |      |   |              |   |
|--------|-------|------------------------|------|---|--------------|---|
| P11.55 | Name  | 0x6098 (Homing method) |      |   | Related mode | - |
|        | Range | -                      | Unit | - | Defaults     | - |

|                  |       |   |      |                |              |   |
|------------------|-------|---|------|----------------|--------------|---|
| P11.56<br>P11.57 | Name  | 0x6099_1 (Search deceleration point signal speed) |      |                | Related mode | - |
|                  | Range | -   | Unit | Command unit/s | Defaults     | - |

|                  |       |                                       |      |                |              |   |
|------------------|-------|---------------------------------------|------|----------------|--------------|---|
| P11.58<br>P11.59 | Name  | 0x6099_2 (Search homing signal speed) |      |                | Related mode | - |
|                  | Range | -                                     | Unit | Command unit/s | Defaults     | - |

|                  |       |                              |      |                             |              |   |
|------------------|-------|------------------------------|------|-----------------------------|--------------|---|
| P11.60<br>P11.61 | Name  | 0x609A (Homing acceleration) |      |                             | Related mode | - |
|                  | Range | -                            | Unit | Command unit/s <sup>2</sup> | Defaults     | - |

|                  |       |                          |      |              |              |   |
|------------------|-------|--------------------------|------|--------------|--------------|---|
| P11.62<br>P11.63 | Name  | 0x60B0 (Position offset) |      |              | Related mode | - |
|                  | Range | -                        | Unit | Command unit | Defaults     | - |

|                  |       |                       |      |                |              |   |
|------------------|-------|-----------------------|------|----------------|--------------|---|
| P11.64<br>P11.65 | Name  | 0x60B1 (Speed offset) |      |                | Related mode | - |
|                  | Range | -                     | Unit | Command unit/s | Defaults     | - |

|        |       |                        |      |      |              |   |
|--------|-------|------------------------|------|------|--------------|---|
| P11.66 | Name  | 0x60B2 (Torque offset) |      |      | Related mode | - |
|        | Range | -                      | Unit | 0.1% | Defaults     | - |

|        |       |                         |      |   |              |   |
|--------|-------|-------------------------|------|---|--------------|---|
| P11.67 | Name  | 0x60B8 (Probe function) |      |   | Related mode | - |
|        | Range | -                       | Unit | - | Defaults     | - |

|        |       |                       |      |   |              |   |
|--------|-------|-----------------------|------|---|--------------|---|
| P11.68 | Name  | 0x60B9 (Probe status) |      |   | Related mode | - |
|        | Range | -                     | Unit | - | Defaults     | - |

|                  |       |  |      |              |              |   |
|------------------|-------|--|------|--------------|--------------|---|
| P11.69<br>P11.70 | Name  | 0x60BA (Probe 1 rising edge position feedback) |      |              | Related mode | - |
|                  | Range | -  | Unit | Command unit | Defaults     | - |

|                  |       |   |      |              |              |   |
|------------------|-------|---|------|--------------|--------------|---|
| P11.71<br>P11.72 | Name  | 0x60BB (Probe 1 falling edge position feedback) |      |              | Related mode | - |
|                  | Range | -   | Unit | Command unit | Defaults     | - |

|                  |       |  |      |              |              |   |
|------------------|-------|--|------|--------------|--------------|---|
| P11.73<br>P11.74 | Name  | 0x60BC (Probe 2 rising edge position feedback) |      |              | Related mode | - |
|                  | Range | -  | Unit | Command unit | Defaults     | - |

|                  |       |   |      |              |              |   |
|------------------|-------|---|------|--------------|--------------|---|
| P11.75<br>P11.76 | Name  | 0x60BD (Probe 2 falling edge position feedback) |      |              | Related mode | - |
|                  | Range | -   | Unit | Command unit | Defaults     | - |

|        |       |                                      |      |   |              |   |
|--------|-------|--------------------------------------|------|---|--------------|---|
| P11.77 | Name  | 0x60D5 (Probe 1 rising edge counter) |      |   | Related mode | - |
|        | Range | -                                    | Unit | - | Defaults     | - |

|        |       |                                       |      |   |              |   |
|--------|-------|---------------------------------------|------|---|--------------|---|
| P11.78 | Name  | 0x60D6 (Probe 1 falling edge counter) |      |   | Related mode | - |
|        | Range | -                                     | Unit | - | Defaults     | - |

|        |       |                                      |      |   |              |   |
|--------|-------|--------------------------------------|------|---|--------------|---|
| P11.79 | Name  | 0x60D7 (Probe 2 rising edge counter) |      |   | Related mode | - |
|        | Range | -                                    | Unit | - | Defaults     | - |

|        |       |                                       |      |   |              |   |
|--------|-------|---------------------------------------|------|---|--------------|---|
| P11.80 | Name  | 0x60D8 (Probe 2 falling edge counter) |      |   | Related mode | - |
|        | Range | -                                     | Unit | - | Defaults     | - |

|        |       |                                       |      |      |              |   |
|--------|-------|---------------------------------------|------|------|--------------|---|
| P11.81 | Name  | 0x60E0 (Maximum forward torque limit) |      |      | Related mode | - |
|        | Range | -                                     | Unit | 0.1% | Defaults     | - |

|        |       |  |      |      |              |   |
|--------|-------|--|------|------|--------------|---|
| P11.82 | Name  | 0x60E1 (Maximum negative torque limit) |      |      | Related mode | - |
|        | Range | -                                      | Unit | 0.1% | Defaults     | - |

|                  |       |                          |      |              |              |   |
|------------------|-------|--------------------------|------|--------------|--------------|---|
| P11.83<br>P11.84 | Name  | 0x60F4 (Position offset) |      |              | Related mode | - |
|                  | Range | -                        | Unit | Command unit | Defaults     | - |

|                  |       |                           |      |              |              |   |
|------------------|-------|---------------------------|------|--------------|--------------|---|
| P11.85<br>P11.86 | Name  | 0x60FC (Position command) |      |              | Related mode | - |
|                  | Range | -                         | Unit | Command unit | Defaults     | - |

|                  |       |                        |      |   |              |   |
|------------------|-------|------------------------|------|---|--------------|---|
| P11.87<br>P11.88 | Name  | 0x60FD (Digital input) |      |   | Related mode | - |
|                  | Range | -                      | Unit | - | Defaults     | - |

|                  |       |                            |      |   |              |   |
|------------------|-------|----------------------------|------|---|--------------|---|
| P11.89<br>P11.90 | Name  | 0x60FE_1 (Physical output) |      |   | Related mode | - |
|                  | Range | -                          | Unit | - | Defaults     | - |

|                  |       |                                   |      |   |              |   |
|------------------|-------|-----------------------------------|------|---|--------------|---|
| P11.91<br>P11.92 | Name  | 0x60FE_2 (Physical output enable) |      |   | Related mode | - |
|                  | Range | -                                 | Unit | - | Defaults     | - |



|                  |       |                       |      |                |              |   |
|------------------|-------|-----------------------|------|----------------|--------------|---|
| P11.93<br>P11.94 | Name  | 0x60FF (Target speed) |      |                | Related mode | - |
|                  | Range | -                     | Unit | Command unit/s | Defaults     | - |

|                  |       |   |      |   |              |   |
|------------------|-------|---|------|---|--------------|---|
| P11.95<br>P11.96 | Name  | 0x6502 (Supported servo operation mode) |      |   | Related mode | - |
|                  | Range | -                                       | Unit | - | Defaults     | - |

**5.12 Group P12: Auxiliary functions**

|        |       |   |      |   |              |   |
|--------|-------|---|------|---|--------------|---|
| P12.00 | Name  | Save parameters to the EEPROM of the driver |      |   | Related mode | - |
|        | Range | 0~1   | Unit | - | Defaults     | 0 |

|        |       |   |      |   |              |   |
|--------|-------|---|------|---|--------------|---|
| P12.01 | Name  | Read parameters from the EEPROM of the driver |      |   | Related mode | - |
|        | Range | 0~1   | Unit | - | Defaults     | 0 |

|        |       |  |      |   |              |   |
|--------|-------|--|------|---|--------------|---|
| P12.02 | Name  | Restore factory default parameter values |      |   | Related mode | - |
|        | Range | 0~1                                      | Unit | - | Defaults     | 0 |

|        |       |                      |      |   |              |   |
|--------|-------|----------------------|------|---|--------------|---|
| P12.03 | Name  | Reset driver failure |      |   | Related mode | - |
|        | Range | 0~1                  | Unit | - | Defaults     | 0 |

|        |       |          |      |   |              |   |
|--------|-------|----------|------|---|--------------|---|
| P12.04 | Name  | Reserved |      |   | Related mode | - |
|        | Range | -        | Unit | - | Defaults     | - |

|        |       |                                    |      |   |              |   |
|--------|-------|------------------------------------|------|---|--------------|---|
| P12.05 | Name  | Reset the encoder multi-turn value |      |   | Related mode | - |
|        | Range | 0~1                                | Unit | - | Defaults     | 0 |

|        |       |  |      |   |              |   |
|--------|-------|--|------|---|--------------|---|
| P12.06 | Name  | Reset the encoder multi-turn value and fault |      |   | Related mode | - |
|        | Range | 0~1  | Unit | - | Defaults     | 0 |

|        |       |              |      |   |              |   |
|--------|-------|--------------|------|---|--------------|---|
| P12.07 | Name  | Reset driver |      |   | Related mode | - |
|        | Range | -            | Unit | - | Defaults     | - |

|        |       |                    |      |   |              |   |
|--------|-------|--------------------|------|---|--------------|---|
| P12.08 | Name  | Reset fault record |      |   | Related mode | - |
|        | Range | 0~1                | Unit | - | Defaults     | 0 |

|        |       |   |      |   |              |    |
|--------|-------|---|------|---|--------------|----|
| P12.09 | Name  | Communication control operation position command type |      |   | Related mode | PS |
|        | Range | 0~1   | Unit | - | Defaults     | 0  |

In the position control mode (P01.00=0), when the position command source is set to communication control (P03.00=3), set the type of position command.

0: Incremental position mode

1: Absolute position mode

|        |       |  |      |       |              |    |
|--------|-------|--|------|-------|--------------|----|
| P12.10 | Name  | Communication control operation start/stop command |      |       | Related mode | PS |
|        | Range | 0~6  | Unit | 0.1ms | Defaults     | 6  |

In the position control mode (P01.00=0), when the position command source is set to communication control (P03.00=3), it is used for communication to write the motor start/stop command.

| P12.10 write value | Description  |
|--------------------|--|
| 0                  | Write: Trigger the motor to stop. After the motor responds to the start-stop command, set P12.10 to 6;   |
| 1                  | Write: Trigger the motor to run forward and stop after the run command set by P04.60. After the motor responds to the start-stop command, set P12.10 to 6;       |
| 2                  | Write: Trigger the motor to run reversely and stop after the running command set by P04.60. After the motor responds to the start-stop command, set P12.10 to 6; |
| 3                  | Write: Trigger the motor to jog forward. After the motor responds to the start-stop command, set P12.10 to 6;  |
| 4                  | Write: Trigger the motor to jog reverse. After the motor responds to the start-stop command, set P12.10 to 6;  |
| 5                  | Write: Trigger the emergency stop of the motor. After the motor responds to the start-stop command, set P12.10 to 6;   |
| 6                  | Write: Meaningless; Read: Indicating that the motor is running or waiting to be triggered to run;  |

|        |       |          |      |   |              |   |
|--------|-------|----------|------|---|--------------|---|
| P12.11 | Name  | Reserved |      |   | Related mode | - |
|        | Range | -        | Unit | - | Defaults     | - |

|        |       |  |      |    |              |     |
|--------|-------|--|------|----|--------------|-----|
| P12.12 | Name  | Communication control demonstration operation delay time |      |    | Related mode | PS  |
|        | Range | 0~65535  | Unit | ms | Defaults     | 100 |

|  |       |  |   |   |              |    |
|--|-------|--|---|---|--------------|----|
| P12.13   | Name  | Communication control demonstration operation start/stop command |   |   | Related mode | PS |
|  | Range | 0~2  | Unit  | - | Defaults     | 0  |
| <p>In the position control mode (P01.00=0), when the position command source is set to communication control (P03.00=3), it is used to write the start/stop command of the motor demonstration operation by communication. In the demo running mode, the motor will start in reciprocating or single direction (P04.65=0/1) according to the running command, speed, acceleration and subtraction time constant set by P04.60 ~ P04.64, and start in positive or negative direction (P04.66=0/1), run the number of times set by P04.67. After completing the set running command each time, after delaying the delay time set by P12.12, restart again and run in this cycle.</p> |       |  |   |   |              |    |
|  |       | P12.13 write value   | Description   |   |              |    |
|  |       | 0  | Write: Trigger the motor to stop the operation of the internal test demonstration.  |   |              |    |
|  |       | 1  | Write: Trigger the motor to start the demonstration operation. After the drive responds to the command, P12.13 is set to 2. |   |              |    |
|  |       | 2  | Writing: Meaningless; reading: Indicating that the motor is working in the demo mode  |   |              |    |

|        |       |                      |      |   |              |   |
|--------|-------|----------------------|------|---|--------------|---|
| P12.14 | Name  | Clear position error |      |   | Related mode | P |
|        | Range | 0~1                  | Unit | - | Defaults     | 0 |

|        |       |          |      |   |              |   |
|--------|-------|----------|------|---|--------------|---|
| P12.15 | Name  | Reserved |      |   | Related mode | - |
|        | Range | -        | Unit | - | Defaults     | - |

|        |       |                         |      |   |              |   |
|--------|-------|-------------------------|------|---|--------------|---|
| P12.16 | Name  | Data sampling channel 1 |      |   | Related mode | - |
|        | Range | 0~65535                 | Unit | - | Defaults     | 0 |

|        |       |                         |      |   |              |   |
|--------|-------|-------------------------|------|---|--------------|---|
| P12.17 | Name  | Data sampling channel 2 |      |   | Related mode | - |
|        | Range | 0~65535                 | Unit | - | Defaults     | 0 |

|        |       |                        |      |       |              |   |
|--------|-------|------------------------|------|-------|--------------|---|
| P12.18 | Name  | Data sampling interval |      |       | Related mode | - |
|        | Range | 0~65535                | Unit | 0.1ms | Defaults     | 0 |

|        |       |                          |      |   |              |   |
|--------|-------|--------------------------|------|---|--------------|---|
| P12.19 | Name  | Data sampling start flag |      |   | Related mode | - |
|        | Range | 0~1                      | Unit | - | Defaults     | 0 |

|        |       |   |      |   |              |   |
|--------|-------|---|------|---|--------------|---|
| P12.20 | Name  | Save motor related parameters to encoder EEPROM |      |   | Related mode | - |
|        | Range | 0~2   | Unit | - | Defaults     | 0 |

Non-manufacturer after-sales personnel or special designation by the manufacturer, please do not operate this parameter, otherwise it may cause abnormal operation of the motor.

|        |      |   |  |  |              |   |
|--------|------|---|--|--|--------------|---|
| P12.21 | Name | Test energy consumption braking action and feedback |  |  | Related mode | - |
|--------|------|---|--|--|--------------|---|

|   |       |     |      |   |          |   |
|---|-------|-----|------|---|----------|---|
|   | Range | 0~2 | Unit | - | Defaults | 0 |
| 0: No effect/wait to start test/test end<br>1: Start dynamic braking/feedback action test<br>2: Abnormality in the energy consumption braking feedback test |       |     |      |   |          |   |

**5.13 Group P13: Monitoring parameter groups**

|   |       |                  |      |   |              |         |
|---|-------|------------------|------|---|--------------|---------|
| P13.00  | Name  | Operation status |      |   | Related mode | -       |
|   | Range | -                | Unit | - | Defaults     | Display |
| Display the operation status of the servo driver.<br>0: The servo driver is not enabled;<br>1: Servo driver is enabled. |       |                  |      |   |              |         |

|  |       |             |      |     |              |         |
|--|-------|-------------|------|-----|--------------|---------|
| P13.01   | Name  | Motor speed |      |     | Related mode | -       |
|  | Range | -           | Unit | rpm | Defaults     | Display |
| Display the actual speed of the servo motor, after rounding the display, the accuracy is 1rpm. |       |             |      |     |              |         |

|   |       |               |      |     |              |         |
|---|-------|---------------|------|-----|--------------|---------|
| P13.02  | Name  | Speed command |      |     | Related mode | -       |
|   | Range | -             | Unit | rpm | Defaults     | Display |
| Display the current speed command value of the servo drive, after rounding the display, the accuracy is 1rpm. |       |               |      |     |              |         |

|  |       |              |      |   |              |         |
|--|-------|--------------|------|---|--------------|---------|
| P13.03   | Name  | Motor torque |      |   | Related mode | -       |
|  | Range | -            | Unit | % | Defaults     | Display |
| Display actual servo motor torque, 100% corresponding to 1 times motor rated torque. |       |              |      |   |              |         |

|   |       |                |      |   |              |         |
|---|-------|----------------|------|---|--------------|---------|
| P13.04  | Name  | Torque command |      |   | Related mode | -       |
|   | Range | -              | Unit | % | Defaults     | Display |
| Display the current torque command value of the servo driver, 100% corresponding to 1 times the motor rated torque. |       |                |      |   |              |         |

|  |       |                   |      |   |              |         |
|--|-------|-------------------|------|---|--------------|---------|
| P13.05   | Name  | Operating current |      |   | Related mode | -       |
|  | Range | -                 | Unit | % | Defaults     | Display |
| Display the actual operating current of the servo motor, 100% corresponds to the rated current of the servo motor. |       |                   |      |   |              |         |

|   |       |                          |      |              |              |         |
|---|-------|--------------------------|------|--------------|--------------|---------|
| P13.07  | Name  | Position command counter |      |              | Related mode | -       |
| P13.08  | Range | -                        | Unit | Command unit | Defaults     | Display |
| In position control mode, during servo operation, the number of position commands that have not been divided and multiplied by the electronic gear ratio are counted and displayed. P13.07 and P13.08 are combined into a 32-bit value, where P13.07 is the low 16-bit value, and P13.08 is the high 16-bit value. Subsequent use P13.07 to represent the 32-bit parameter. |       |                          |      |              |              |         |

|  |       |                            |      |              |              |         |
|--|-------|----------------------------|------|--------------|--------------|---------|
| P13.09   | Name  | Position command counter * |      |              | Related mode | -       |
| P13.10   | Range | -                          | Unit | Encoder unit | Defaults     | Display |
| <p>In position control mode, during servo operation, the number of position commands that have not been divided and multiplied by the electronic gear ratio are counted and displayed. P13.09 and P13.10 are combined into a 32-bit value, where P13.09 is the low 16-bit value, and P13.10 is the high 16-bit value. Subsequent use P13.09 to represent the 32-bit parameter.</p> |       |                            |      |              |              |         |

|  |       |                           |      |              |              |         |
|--|-------|---------------------------|------|--------------|--------------|---------|
| P13.11   | Name  | Position feedback counter |      |              | Related mode | -       |
| P13.12   | Range | -                         | Unit | Encoder unit | Defaults     | Display |
| <p>In position control mode, during servo operation, the number of position commands that have not been divided and multiplied by the electronic gear ratio are counted and displayed. P13.07 and P13.08 are combined into a 32-bit value, where P13.07 is the low 16-bit value, and P13.08 is the high 16-bit value. Subsequent use P13.07 to represent the 32-bit parameter.</p> |       |                           |      |              |              |         |

|   |       |                            |      |              |              |         |
|---|-------|----------------------------|------|--------------|--------------|---------|
| P13.13  | Name  | Position deviation counter |      |              | Related mode | -       |
| P13.14  | Range | -                          | Unit | Command unit | Defaults     | Display |
| <p>In position control mode, statistics and display the position command deviation value. P13.13 and P13.14 are combined into a 32-bit value, where P13.13 is the low 16-bit value, and P13.14 is the high 16-bit value. Subsequent use P13.13 to represent the 32-bit parameter.</p> |       |                            |      |              |              |         |

|   |       |                              |      |              |              |         |
|---|-------|------------------------------|------|--------------|--------------|---------|
| P13.15  | Name  | Position deviation counter * |      |              | Related mode | -       |
| P13.16  | Range | -                            | Unit | Encoder unit | Defaults     | Display |
| <p>In the position control mode, statistics and display the position deviation value after the electronic gear ratio is divided and multiplied. P13.15 and P13.16 are combined into a 32-bit value, where P13.15 is the low 16-bit value, and P13.16 is the high 16-bit value. Subsequent use P13.15 to represent the 32-bit parameter.</p> |       |                              |      |              |              |         |

|  |       |                        |      |     |              |         |
|--|-------|------------------------|------|-----|--------------|---------|
| P13.17   | Name  | Position command speed |      |     | Related mode | -       |
|  | Range | -                      | Unit | rpm | Defaults     | Display |
| <p>Display the speed value corresponding to the position command of a single position control cycle of the driver.</p> |       |                        |      |     |              |         |

|  |       |                            |      |     |              |         |
|--|-------|----------------------------|------|-----|--------------|---------|
| P13.18   | Name  | Position command frequency |      |     | Related mode | -       |
|  | Range | -                          | Unit | KHz | Defaults     | Display |
| <p>Display the pulse frequency corresponding to the position command of a single position control cycle of the driver.</p> |       |                            |      |     |              |         |

|        |       |                         |      |   |              |         |
|--------|-------|-------------------------|------|---|--------------|---------|
| P13.19 | Name  | Input signal monitoring |      |   | Related mode | -       |
|        | Range | -                       | Unit | - | Defaults     | Display |

Display the current level status of the IN hardware terminal of the driver. BIT corresponding to "1" means the driver INx terminal optocoupler is turned on, BIT corresponding to "0" means that the driver INx terminal optocoupler is not turned on.

| BIT  | Description      |
|------|------------------|
| 0    | IN1 input status |
| 1    | IN2 input status |
| 2    | IN3 input status |
| 3    | IN4 input status |
| 4    | IN5 input status |
| 5    | IN6 input status |
| 9~15 | Reserved         |

|        |       |                          |      |   |              |         |
|--------|-------|--------------------------|------|---|--------------|---------|
| P13.20 | Name  | Output signal monitoring |      |   | Related mode | -       |
|        | Range | -                        | Unit | - | Defaults     | Display |

Display the current status of the OUT hardware terminal of the drive. BIT corresponding to "1" means that the OUTx terminal of the driver has a signal output (only means that the current OUTx terminal of the driver has a driving signal, does not mean that the current driver's output port is normally output), and BIT corresponding to "0" means that there is no output signal from the OUTx terminal of the driver.

| BIT  | Description        |
|------|--------------------|
| 0    | OUT1 output status |
| 1    | OUT1 output status |
| 2    | OUT1 output status |
| 3    | OUT1 output status |
| 4~15 | Reserved           |

|                  |       |                                   |      |              |              |         |
|------------------|-------|-----------------------------------|------|--------------|--------------|---------|
| P13.21<br>P13.22 | Name  | Current mechanical Angle of motor |      |              | Related mode | -       |
|                  | Range | -                                 | Unit | Encoder unit | Defaults     | Display |

Display the current mechanical angle of the motor (encoder unit), 0 corresponds to the mechanical angle 0. P13.21 and P13.22 are combined into a 32-bit value, where P13.21 is the low 16-bit value, and P13.22 is the high 16-bit value. Subsequent use P13.21 to represent the 32-bit parameter. Actual mechanical angle =  $(P13.21 \div \text{encoder pulse number}) \times 360^\circ$

|        |       |                                   |      |        |              |         |
|--------|-------|-----------------------------------|------|--------|--------------|---------|
| P13.23 | Name  | Current electrical Angle of motor |      |        | Related mode | -       |
|        | Range | -                                 | Unit | Degree | Defaults     | Display |

Display the current electrical angle of the motor,  $P13.23 = (P13.21 \div \text{encoder pulse number}) \times 360^\circ$

|        |       |                               |      |      |              |         |
|--------|-------|-------------------------------|------|------|--------------|---------|
| P13.24 | Name  | Current voltage of the driver |      |      | Related mode | -       |
|        | Range | -                             | Unit | 0.1V | Defaults     | Display |

|                  |       |                         |      |   |              |         |
|------------------|-------|-------------------------|------|---|--------------|---------|
| P13.25<br>P13.26 | Name  | Encoder status register |      |   | Related mode | -       |
|                  | Range | -                       | Unit | - | Defaults     | Display |

Display the status information of the encoder. P13.25 and P13.26 are combined into a 32-bit value, where P13.25 is the low 16-bit value, and P13.26 is the high 16-bit value. Subsequent use P13.25 to represent the 32-bit parameter. The 32-bit data corresponds to 1 to indicate that the event has occurred, and 0 to indicate that there is no such event. The detailed description is as follows:

| BIT   | Description   |
|-------|---|
| 0     | Absolute encoder fault  |
| 1     | Absolute encoder command check bit fault  |
| 2     | Absolute encoder delimiter fault  |
| 3     | Absolute encoder overspeed fault  |
| 4     | Absolute encoder status fault   |
| 5     | Absolute encoder count fault  |
| 6     | Absolute encoder count overflow fault   |
| 7     | Absolute encoder overheating fault  |
| 8     | Absolute encoder multi-turn data fault  |
| 9     | Absolute encoder battery fault 1  |
| 10    | Absolute encoder battery fault 2  |
| 11    | Absolute encoder data receiving timeout fault 1   |
| 12    | Absolute encoder data receiving timeout fault 2   |
| 13    | Absolute encoder receiving command fault  |
| 14    | Absolute encoder verification fault   |
| 15    | Absolute encoder check command error, if this error occurs, please contact the manufacturer |
| 16    | Absolute encoder receiving status flag fault  |
| 17    | Absolute encoder receiving fault  |
| 18    | Incremental encoder hall signal fault   |
| 19    | Incremental encoder disconnection fault   |
| 20    | Incremental encoder Z phase signal latch flag   |
| 21    | Incremental encoder Z phase signal last cycle latch flag                                    |
| 22    | Encoder type/resolution setting error flag  |
| 23    | Encoder calibration fault flag  |
| 24    | Bus type incremental encoder index signal flag  |
| 25    | Index position latch flag of bus type incremental encoder                                   |
| 26    | UVW signal error flag of bus type incremental encoder                                       |
| 27:28 | Bus type incremental encoder index status   |
| 29~31 | Reserved  |

| P13.27  | Name  | External pulse counter |      |              | Related mode | -       |
|---|-------|------------------------|------|--------------|--------------|---------|
| P13.28  | Range | -                      | Unit | Command unit | Defaults     | Display |
| Displays the number of external input pulses received by the driver since the last reset. P13.27 and p13.28 are combined into a 32-bit value, where p13.27 is the low 16 bit value and p13.28 is the high 16 bit value. Subsequently, p13.27 is used to represent the 32-bit parameter. |       |                        |      |              |              |         |

|  |       |  |      |               |              |         |
|--|-------|--|------|---------------|--------------|---------|
| P13.29                                     | Name  | Frequency division output pulse counting |      |               | Related mode | -       |
|  | Range | -  | Unit | Command pulse | Defaults     | Display |
| DRV series servo drivers are not available |       |  |      |               |              |         |

|   |       |                               |      |              |              |         |
|---|-------|-------------------------------|------|--------------|--------------|---------|
| P13.30  | Name  | Current position of the motor |      |              | Related mode | -       |
| P13.31  | Range | -                             | Unit | Command unit | Defaults     | Display |
| Display the actual position of the motor shaft, the unit is command pulse. P13.30 and P13.31 are combined into a 32-bit signed value, where P13.30 is the low 16-bit value, and P13.31 is the high 16-bit value. Subsequent use P13.30 to represent the 32-bit parameter. |       |                               |      |              |              |         |

|  |       |                         |      |              |              |         |
|--|-------|-------------------------|------|--------------|--------------|---------|
| P13.32   | Name  | Target position(0x607A) |      |              | Related mode | -       |
| P13.33   | Range | -                       | Unit | Command unit | Defaults     | Display |
| In CANopen and EtherCAT models, it is used to display the current target position 0x607A. P13.32 and P13.33 are combined into a 32-bit signed value, where P13.32 is the low 16-bit value, and P13.33 is the high 16-bit value. Subsequent use P13.32 to represent the 32-bit parameter. |       |                         |      |              |              |         |

|  |       |            |      |   |              |         |
|--|-------|------------|------|---|--------------|---------|
| P13.36   | Name  | Fault code |      |   | Related mode | -       |
|  | Range | -          | Unit | - | Defaults     | Display |
| For the specific content of the fault code, please refer to the "Troubleshooting" chapter. |       |            |      |   |              |         |

|   |       |                                 |      |              |              |         |
|---|-------|---------------------------------|------|--------------|--------------|---------|
| P13.40  | Name  | Motor encoder single-turn value |      |              | Related mode | -       |
| P13.41  | Range | -                               | Unit | Encoder unit | Defaults     | Display |
| Display the current single-turn value of the motor encoder, ranging from 0 to encoder resolution. P13.40 and P13.41 are combined into a 32-bit unsigned value, where P13.40 is the low 16-bit value and P13.41 is the high 16-bit value. Subsequent use P13.40 to represent the 32-bit parameter. |       |                                 |      |              |              |         |

|  |       |                                |      |     |              |         |
|--|-------|--------------------------------|------|-----|--------------|---------|
| P13.42   | Name  | Motor encoder multi-turn value |      |     | Related mode | -       |
| P13.43   | Range | -                              | Unit | Lap | Defaults     | Display |
| Display the current multi-turn value of the motor encoder. P13.42 and P13.43 are combined into a 32-bit signed value, where P13.42 is the low 16-bit value and P13.43 is the high 16-bit value. Subsequent use P13.42 to represent the 32-bit parameter. |       |                                |      |     |              |         |



## Chapter 6 Chapter 6 Communication

The servo Driver has Modbus RTU (RS-232, RS-485) communication function, with the upper computer communication software, it can realize multiple functions such as parameter modification, parameter query and servo Driver status monitoring.

### 1.2 MODBUS Communication

The RS-485 communication protocol has a single-master multi-slave communication mode, which can support network operation of multiple servo Drivers. RS-232 communication protocol does not support networking of multiple servo Drivers.

#### 1.2.1 Hardware wiring

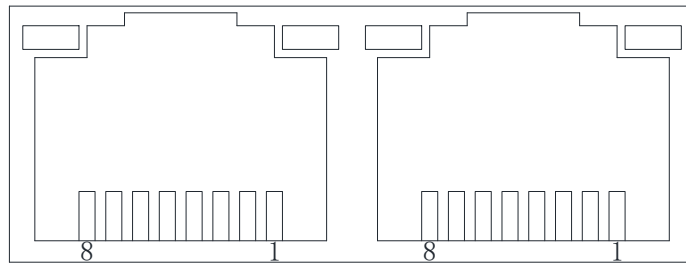

| Signal | Pin number | Function                 |
|--------|------------|--------------------------|
| RS485+ | 1          | RS485 communication port |
| RS485- | 2          |                          |
| -      | 3          | -                        |
| CAN_H  | 4          | CAN communication port   |
| CAN_L  | 5          |                          |
| -      | 6          | -                        |
| DGND   | 7          | GND signal               |
| -      | 8          | -                        |

#### 1.2.2 Communication parameter setting

- Servo Driver default communication settings:

| Communication mode  | Axis address               | Baud rate  | Data Format                            |
|---------------------|----------------------------|------------|--|
| RS485 communication | 1                          | 115200 bps | 1 start bit + 8 data bits + 1 stop bit |
| RS232 communication | 1 (fixed and unchangeable) | 115200 bps | 1 start bit + 8 data bits + 1 stop bit |

## 1、RS485 communication settings:

(1) Set the servo Driver axis address P08.00

When multiple servo Drivers are networked, each Driver can only have a unique address, otherwise it will cause abnormal communication and fail to communicate. in:

0: broadcast address

1~127: slave address

The host computer can write to all slave Drivers through the broadcast address. The slave Driver receives the broadcast address data frame and performs corresponding operations, but does not respond to data.

(2) **Set the communication rate between the servo Driver and the host computer P08.01**

The speed of the servo Driver and the communication speed of the host computer must be set to be consistent, otherwise the communication will not be possible. When multiple servo Drivers are networked, if the communication baud rate of a servo Driver is inconsistent with the host, it will cause the servo axis communication error and may affect the normal communication of other servo Drivers.

(3) **Set the data frame format P08.02 for the communication between the servo driver and the host computer**

Servo Driver provides 6 communication data formats

| P08.02 set value | Communication data frame format                             |
|------------------|---|
| 0                | 1 start bit + 8 data bits + 1 stop bit                      |
| 1                | 1 start bit + 8 data bits + 2 stop bits                     |
| 2                | 1 start bit + 8 data bits + 1 even parity bit + 1 stop bit  |
| 3                | 1 start bit + 8 data bits + 1 even parity bit + 2 stop bits |
| 4                | 1 stop bit + 8 data bits + 1 odd parity bit + 1 stop bit    |
| 5                | 1 stop bit + 8 data bits + 1 odd parity bit + 2 stop bits   |

● Note: The data frame format of the host computer must conform to the above format, otherwise it cannot communicate with the Driver

## 2、RS232 Communication settings:

★ Description of related parameters

| parameter | name                             | Predetermined area | Function                                      | Effective time              | Factory setting |
|-----------|----------------------------------|--------------------|---|-----------------------------|-----------------|
| P08.30    | RS232 communication axis address | -                  | Set the station number of RS232 communication | After saving and restarting | 1               |
| P08.31    | RS232 communication baud rate    | 0~5                | Set the baud rate of RS232 communication      | After saving and restarting | 5               |
| P08.32    | RS232                            | 0~5                | Set the data format of RS232                  | After saving and            | 0               |

|  |                           |  |               |            |  |
|--|---------------------------|--|---------------|------------|--|
|  | communication data format |  | communication | restarting |  |
|--|---------------------------|--|---------------|------------|--|

### 1.3 MODBUS communication protocol

Modbus protocol, designed by MODDICON company, is a bus protocol that allows the master station and one or more slave stations to share data. The data is composed of 16-bit registers. The master station can read and write a single register or multiple registers. The standard Modbus port on the Modicon controller uses an RS-232 compatible serial interface, which defines the connector, wiring cable, signal level, transmission baud rate and parity. Controller communication uses master-slave technology, that is, the host initiates data transmission, which is called query. Other devices (slave) return response data to the query, or process the actions required by the query. The host device includes a processor, a programmer and a PLC. The slaves include programmable controllers, servo Drivers and stepper Drivers. The master-slave query-feedback mechanism is as follows:

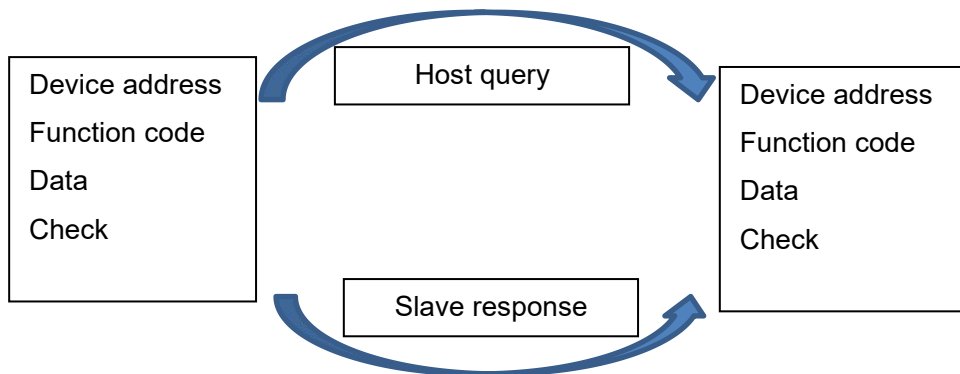

Note: The communication data frame structure of this servo Driver adopts RTU mode.

The MODBUS communication function code used by the servo Driver is described as follows:

| Function code | Definition                   |
|---------------|------------------------------|
| 0x03          | Read register data           |
| 0x06          | Write single register data   |
| 0x10          | Write multiple register data |

- **Note: The relationship between the parameter number in the manual and the register address in Modbus communication: if**

**the parameter number is P08.02, the Modbus communication register address is 802 (decimal)**

### 1.3.1 Read register data: 0x03

Request frame format:

|                |  |
|----------------|--|
| START          | Idle time greater than or equal to 3.5 characters, indicating the start of a frame |
| ADDR           | Servo axis address   |
| CMD            | Function code: 0x03  |
| REGISTER_ADDRH | Register start address high byte   |
| REGISTER_ADDRL | Register start address low byte  |
| DATA_NUMBERH   | The number of registers to be read N (H) high byte                                 |
| DATA_NUMBERL   | The number of registers to be read N (L) low byte                                  |
| CRCL           | CRC check code low byte  |
| CRCH           | CRC check code high byte   |
| END            | Idle time greater than or equal to 3.5 characters, one frame ends                  |

Note: The register start address range is 0x0000 to 0xFFFF, and the register number range is 0x1 to 0x7D

Response frame format:

|             |  |
|-------------|--|
| START       | Idle time greater than or equal to 3.5 characters, indicating the start of a frame |
| ADDR        | Servo axis address   |
| CMD         | Function code: 0x03  |
| DATA_LENGTH | The number of data bytes returned is equal to the number of registers N*2          |
| DATA[0]     | High byte of starting data value   |
| DATA[1]     | Low byte of starting data value  |
| DATA[...]   | ...  |
| DATA[N*2-1] | Last data value low byte   |
| CRCL        | CRC check code low byte  |
| CRCH        | CRC check code high byte   |
| END         | Idle time greater than or equal to 3.5 characters, one frame ends                  |

Example:

Host sends request frame:

|      |      |      |      |      |      |      |      |
|------|------|------|------|------|------|------|------|
| 0x01 | 0x03 | 0x00 | 0x64 | 0x00 | 0x02 | CRCL | CRCH |
|------|------|------|------|------|------|------|------|

This request frame means: read 2 (0x0002) word length data from the servo Driver whose axis address is 0x01 and the start register address is 100 (0x0064).

Slave response frame:

|      |      |      |      |      |      |      |      |
|------|------|------|------|------|------|------|------|
| 0x01 | 0x03 | 0x04 | 0x01 | 0x20 | 0x00 | 0x59 | CRCL |
|------|------|------|------|------|------|------|------|

The response frame means: the slave returns 4 bytes (2 words long) of data, and the data content is 0x0120, 0x0059.

### 1.3.2 Write a single register: 0x06

Request frame format:

|                |  |
|----------------|--|
| START          | Idle time greater than or equal to 3.5 characters, indicating the start of a frame |
| ADDR           | Servo axis address   |
| CMD            | Function code: 0x06  |
| REGISTER_ADDRH | High byte of written register address  |
| REGISTER_ADDRL | Low byte of written register address   |
| DATA[0]        | Write high byte of data  |
| DATA[1]        | Write data low byte  |
| CRCL           | CRC check code low byte  |
| CRCH           | CRC check code high byte   |
| END            | Idle time greater than or equal to 3.5 characters, one frame ends                  |

Response frame format:

|                |  |
|----------------|--|
| START          | Idle time greater than or equal to 3.5 characters, indicating the start of a frame |
| ADDR           | Servo axis address   |
| CMD            | Function code: 0x06  |
| REGISTER_ADDRH | High byte of written register address  |
| REGISTER_ADDRL | Low byte of written register address   |
| DATA[0]        | Write high byte of data  |
| DATA[1]        | Write data low byte  |
| CRCL           | CRC check code low byte  |
| CRCH           | CRC check code high byte   |
| END            | Idle time greater than or equal to 3.5 characters, one frame ends                  |

Example:

Host sends request frame:

|      |      |      |      |      |      |      |      |
|------|------|------|------|------|------|------|------|
| 0x01 | 0x06 | 0x00 | 0x64 | 0x00 | 0x02 | CRCL | CRCH |
|------|------|------|------|------|------|------|------|

This request frame means: To the servo Driver whose axis address is 0x01, the register address is 100 (0x0064) to write the data value 0x0002.

Slave response frame:

|      |      |      |      |      |      |      |      |
|------|------|------|------|------|------|------|------|
| 0x01 | 0x06 | 0x00 | 0x64 | 0x00 | 0x02 | CRCL | CRCH |
|------|------|------|------|------|------|------|------|

This response frame means: the host successfully writes the data into the servo Driver register.

### 1.3.3 Writing multiple registers: 0x10

Request frame format:

|                |  |
|----------------|--|
| START          | Idle time greater than or equal to 3.5 characters, indicating the start of a frame |
| ADDR           | Servo axis address   |
| CMD            | Function code: 0x10  |
| REGISTER_ADDRH | High byte of the start address of the written register                             |
| REGISTER_ADDRL | Low byte of the start address of the written register                              |
| DATA_NUMBERH   | Need to write the number of registers N (H) high byte                              |
| DATA_NUMBERL   | Need to write the number of registers N (L) low byte                               |
| DATA_LENGTH    | Need to write the number of bytes corresponding to the number of registers N*2     |
| DATA[0]        | Write high byte of start register data   |
| DATA[1]        | Write low byte of start register data  |
| DATA[...]      | ...  |
| DATA[N*2-1]    | Write low byte of last register data   |
| CRCL           | CRC check code low byte  |
| CRCH           | CRC check code high byte   |
| END            | Idle time greater than or equal to 3.5 characters, one frame ends                  |

Response frame format:

|                |  |
|----------------|--|
| START          | Idle time greater than or equal to 3.5 characters, indicating the start of a frame |
| ADDR           | Servo axis address   |
| CMD            | Function code: 0x10  |
| REGISTER_ADDRH | High byte of the start address of the written register                             |
| REGISTER_ADDRL | Low byte of the start address of the written register                              |

|              |   |
|--------------|---|
| DATA_NUMBERH | Need to write the number of registers N (H) high byte             |
| DATA_NUMBERL | Need to write the number of registers N (L) low byte              |
| CRCL         | CRC check code low byte   |
| CRCH         | CRC check code high byte  |
| END          | Idle time greater than or equal to 3.5 characters, one frame ends |

Note: The maximum number of registers that can be written at one time is 120.

Example:

Host sends request frame:

|      |      |      |      |      |      |      |      |      |      |      |      |      |
|------|------|------|------|------|------|------|------|------|------|------|------|------|
| 0x01 | 0x10 | 0x00 | 0x64 | 0x00 | 0x02 | 0x04 | 0x12 | 0x00 | 0x00 | 0x52 | CRCL | CRCH |
|------|------|------|------|------|------|------|------|------|------|------|------|------|

This request frame means: To the servo driver with the axis address 0x01, the starting register address is 100 (0x0064) to write 2 (0x0002) word length data (4 bytes), and the write data is 0x1200, 0x0052.

Slave response frame:

|      |      |      |      |      |      |      |      |
|------|------|------|------|------|------|------|------|
| 0x01 | 0x10 | 0x00 | 0x64 | 0x00 | 0x02 | CRCL | CRCH |
|------|------|------|------|------|------|------|------|

This response frame means: the host successfully writes the data into the servo Driver register.

### 1.3.4 Error response frame format

|            |  |
|------------|--|
| START      | Idle time greater than or equal to 3.5 characters, indicating the start of a frame |
| ADDR       | Servo axis address   |
| CMD        | 0x80 + function code   |
| ERROR_CODE | Error code   |
| CRCL       | CRC check code low byte  |
| CRCH       | CRC check code high byte   |
| END        | Idle time greater than or equal to 3.5 characters, one frame ends                  |

Error code

| Error code | Coding description      |
|------------|-------------------------|
| 0x01       | Illegal function code   |
| 0x02       | Illegal data address    |
| 0x03       | Illegal data            |
| 0x04       | Slave equipment failure |

Example:

Host sends request frame:

|      |      |      |      |      |      |      |      |
|------|------|------|------|------|------|------|------|
| 0x01 | 0x03 | 0x00 | 0x64 | 0x00 | 0x02 | CRCL | CRCH |
|------|------|------|------|------|------|------|------|

This request frame means: read 2 (0x0002) word length data from the servo Driver whose axis address is 0x01 and the start register address is 100 (0x0064).

Slave response frame:

|      |      |      |      |      |      |      |      |
|------|------|------|------|------|------|------|------|
| 0x01 | 0x03 | 0x04 | 0x01 | 0x20 | 0x00 | 0x59 | CRCL |
|------|------|------|------|------|------|------|------|

The response frame means: the slave returns 4 bytes (2 words long) of data, and the data content is 0x0120, 0x0059.

If the slave responds as

|      |      |      |      |      |
|------|------|------|------|------|
| 0x01 | 0x83 | 0x02 | CRCL | CRCH |
|------|------|------|------|------|

The response frame indicates: 0x83 indicates a communication error, and the error code is 0x02

### 1.3.5 CRC check

The host computer and servo communication must use a consistent CRC check algorithm, otherwise a CRC check error will occur, resulting in communication failure, and the servo Driver will not report the CRC check error. The servo Driver adopts 16-bit CRC, with the low byte in front and the high byte in the back. The CRC function is as follows:

```

unsigned short CalcCRCbyAlgorithm(unsigned char* pDataBuffer, unsigned long usDataLen)
{
const unsigned short POLYNOMIAL = 0xA001;
unsigned short wCrc;
int iBite, iBit;
wCrc = 0xFFFF;
for(iBite = 0; iByte < usDataLen; iBite++)
{
wCrc ^= *( pDataBuffer + iByte);
for(iBit = 0; iBit <= 7; iBit++)
{
if(wCrc & 0x0001)
{
wCrc >>= 1;
wCrc ^= POLYNOMIAL;
}
}
}
}
    
```



```
else
{
    wCrc >>= 1;
}
}
}
return wCrc;
}
```

## **1.4 Use of servo Driver debugging software**

Please refer to the software user manual for instructions on the use of the servo Driver debugging software, no additional instructions here

## Chapter 7 Chapter 7 Troubleshooting

### 7.1 Fault list

| LED State | Illustrate   |
|-----------|--|
|           | Steady green light: the Driver is not enabled                    |
|           | Green light flashes: the Driver is enabled, normal working state |
|           | 1 green, 1 red: Driver overcurrent                               |
|           | 1 green, 2 red: Driver overvoltage                               |
|           | 1 green, 3 red: the internal voltage of the Driver is wrong      |
|           | 1 green, 4 red: encoder out of tolerance alarm                   |
|           | 1 green, 5 red: Driver undervoltage                              |
|           | 1 green, 6 red: parameter storage error                          |
|           | 1 green, 7 red: abnormal braking (no feedback/timeout)           |
|           | 1 green, 8 red: encoder failure                                  |
|           | 1 green, 9 red: limit input error warning                        |
|           | 1 green, 10 red: motor thermal overload warning                  |
|           | 1 green, 11 red: motor command overload warning                  |
|           | 1 green, 12 red: motor output saturation overtime warning        |
|           | 1 green, 13 red: CAN bus failure                                 |
|           | 1 green, 14 red: CAN bus is disconnected                         |
|           | 1 green, 15 red: abnormal software operation                     |
|           | 1 green, 16 red: other undefined faults                          |

### 7.2 Fault codes

Due to the large number of fault codes, the LED lights cannot fully indicate, and part of the LED indication status is combined with multiple fault codes, resulting in the same error checking. The current fault code can be read through the P13.36 parameter. If there are multiple fault codes, each time this parameter is read, another fault code will be automatically uploaded and cycled. If there is a fault code 121/170, the data read for the first time is 170, the data read for the next time is 121, and the data read for the next time is 170... and so on.

The following table shows the fault content of the fault code:

| Fault code | Fault content   |
|------------|---|
| AL.000     | Normal status   |
| AL.100     | Parameter reading error<br>Generally, it occurs after firmware upgrade or parameter reading operation is performed. The version |

|                  |  |
|------------------|--|
|                  | <p>of the parameter stored in the EEPROM of the Driver does not match or the verification is wrong. You need to re-import the firmware and save it.</p> <p>An alarm occurs when the Driver has not upgraded the firmware, and the Driver internal parameter reading error is caused. Please completely power off the Driver for 30s, then restart the Driver to check whether there is an alarm.</p> <p>After the operation in step B, the Driver still alarms, please try to restore the factory settings, then power off for 30s, then restart the Driver, if the Driver still alarms, please contact the manufacturer for after-sales or replacement. If there is no alarm, please reset the parameters and continue to use it again.</p> |
| AL.101           | <p>Parameter saving error</p> <p>Appears in the parameter saving process, usually due to abnormal EEPROM chip communication, please completely power off the Driver for 30s, then restart the Driver and perform a parameter saving test. If the warning still appears, please contact the manufacturer for after-sales or replacement.</p>  |
| AL.103           | <p>Driver program is running abnormally</p> <p>The Driver program runs abnormally, please contact the manufacturer for after-sales service.</p>  |
| AL.105           | <p>Driver program is running abnormally</p> <p>The Driver program runs abnormally, please contact the manufacturer for after-sales service.</p>  |
| AL.110<br>AL.111 | <p>AL.110: Driver IPM module overcurrent<br/>AL.111: Driver ADC overcurrent</p> <p>Whether the motor collides with the machine and causes a stall</p> <p>If the motor P06.00, P06.01, P06.02, P06.28, P06.29 are set improperly, try to restore the Driver parameters, and after restarting, check if there is still a warning. If the warning still appears, please contact the manufacturer for after-sales service.</p> <p>By setting the P05.04 parameter, try to reduce the overload multiple of the Driver to test whether there is an alarm.</p>  |
| AL.112<br>AL.113 | <p>AL.112: Motor command overload<br/>AL.113: Motor overheated</p> <p>Check whether the motor collides with the machine and causes a stall</p> <p>Check whether the encoder cable is connected correctly, such as: the motor encoder cable is not connected correctly when there are multiple axes</p> <p>Monitor the Driver d03.tF, check the running torque of the motor, and judge whether it is caused by long-term overload</p>   |
| AL.114           | <p>Driver IPM module over temperature</p> <p>Check the Driver housing temperature and ventilation and heat dissipation conditions</p> <p>Check if the Driver fan rotates normally</p>  |
| AL.115           | <p>Driver internal voltage error</p> <p>The internal voltage failure of the Driver is generally caused by the internal hardware of the Driver. Please contact the manufacturer for after-sales service.</p>  |
| AL.120           | <p>Driver encoder interference</p> <p>Please check whether the motor PE wire connection is reliable</p> <p>Check the encoder plug connection is reliable</p> <p>Replace the Driver to check whether the fault is caused by the motor encoder</p>   |
| AL.121           | <p>Encoder communication error</p>   |

|        |  |
|--------|--|
|        | <p>When the fault occurs when the power is turned on, it usually alarms AL.170 at the same time, please check the connection of the encoder extension cable is reliable</p> <p>If the Driver only alarms AL.121, it is usually caused by a malfunction of the encoder, please replace the motor.</p> |
| AL.123 | Encoder CRC check failure  |
| AL.124 | Encoder Z phase signal failure   |
| AL.125 | Encoder counting failure   |
| AL.126 | <p>Encoder disconnection fault</p> <p>A. Check whether the encoder cable is reliably connected</p>   |
| AL.127 | <p>Encoder failure</p> <p>Appears during power-on initialization, the incremental encoder reads the Hall signal incorrectly when power-on, and the communication encoder shows that the Driver cannot communicate with the encoder</p> <p>Please check the encoder cable connection is reliable</p>  |
| AL.128 | <p>Encoder type setting error</p> <p>Please check if the parameter value of P00.34 is set correctly</p>  |
| AL.129 | Encoder data receiving timeout   |
| AL.140 | Position error overflow  |
| AL.150 | Braking resistance parameter setting is too small  |
| AL.160 | <p>FPGA parameter initialization error</p> <p>It appears when the Driver is powering on and initializing, power off the Driver for 30s, then restart it to see if it still alarms, if it still alarms, please replace the Driver.</p>  |
| AL.161 | <p>SPI communication error detected by the program</p> <p>Update the Driver and contact the manufacturer for after-sales service.</p>  |
| AL.162 | Read encoder EEPROM failure  |
| AL.163 | Save the encoder EEPROM failure  |
| AL.164 | <p>Encoder data is incorrect</p> <p>It appears during power-on initialization, because the encoder has not been calibrated, please contact the manufacturer for after-sales service.</p>   |
| AL.165 | <p>Encoder data is incorrect</p> <p>It occurs during power-on initialization and the encoder's checksum error is caused. Please power off and restart after 30s. If it still alarms, please contact the manufacturer for after-sales or replace the motor.</p>                                       |
| AL.166 | Write encoder EEPROM failure   |
| AL.167 | Write encoder EEPROM failure (when read back for verification)   |
| AL.168 | Read encoder EEPROM failure  |
| AL.169 | Read encoder EEPROM failure  |
| AL.170 | <p>Read encoder EEPROM failure</p> <p>It occurs during power-on initialization, usually due to the encoder extension cable. Please check that the extension cable is connected correctly.</p>  |
| AL.171 | <p>FPGA initialization error</p> <p>It is caused by abnormal communication between DSP and FPGA during power-on initialization.</p>  |

|        |  |
|--------|--|
| AL.200 | <p>Control mode setting error</p> <p>Please check the P01.00 parameter setting value, whether it meets the requirements of the manual, or contact the manufacturer.</p>  |
| AL.201 | <p>Position command source setting error</p> <p>Please check the P03.00 parameter setting value, whether it meets the requirements of the manual, or contact the manufacturer.</p>   |
| AL.202 | <p>Speed command source setting error</p> <p>Please check the P04.00 parameter setting value, whether it meets the requirements of the manual, or contact the manufacturer.</p>  |
| AL.203 | <p>Torque command source setting error</p> <p>A. Please check the parameter settings of P05.00, P05.01, and P05.02 to see if they meet the requirements of the manual, or contact the manufacturer.</p>  |
| AL.210 | <p>Driver bus voltage is high</p> <p>Please connect the braking resistor or check the quality and resistance of the braking resistor.</p> <p>Please check whether the AC input power is too high and the Driver input power requirement is below 260VAC.</p>   |
| AL.211 | <p>Driver bus voltage is low</p> <p>Please check whether the AC input power is indeed too low and the Driver input power requirement is below 170VAC.</p> <p>Replace with a new Driver to check if the Driver is damaged.</p>  |
| AL.212 | <p>Driver bus voltage is high</p> <p>It occurs when the bus voltage of the Driver is momentarily higher than the alarm threshold.</p> <p>Please connect the braking resistor or check the quality and resistance of the braking resistor.</p> <p>Please check if it is indeed caused by the high AC input power, the Driver input power requirement is below 260VAC</p>  |
| AL.213 | <p>Torque limit alarm output</p>   |
| AL.220 | <p>Encoder battery warning</p> <p>When the battery voltage is lower than 3.3V during power-on initialization, please replace the battery in time.</p> <p>Use the AF.CEN function to clear the alarm</p>  |
| AL.221 | <p>Encoder battery failure</p> <p>The current encoder battery voltage is lower than 2.8V, please replace the battery</p> <p>The encoder battery is disconnected from the encoder.</p> <p>Use the AF.CEE function to clear the alarm</p> <p>When this alarm occurs, the multi-turn encoder data of the Driver is already incorrect, and the zero point needs to be reset</p>  |
| AL.222 | <p>Encoder multi-turn data alarm</p> <p>It occurs during power-on initialization, usually due to the previous disconnection of the encoder battery and the encoder.</p> <p>The battery voltage is too low or the battery connection line is abnormal</p> <p>Use the AF.CEN function to clear the alarm</p> <p>When this alarm occurs, the multi-turn encoder data of the Driver is already incorrect, and the zero point needs to be reset</p> |

|        |   |
|--------|---|
| AL.230 | Speeding alarm  |
| AL.231 | Speed regulator output saturation<br>Check whether the collision is caused<br>Check whether the parameter settings of P06.00 and P06.01 are correct<br>Check whether the power cable and encoder extension cable are properly connected         |
| AL.240 | Location is out of tolerance<br>Check whether the power cord is properly connected<br>Check whether the electronic gear ratio parameter setting is correct<br>Check whether the frequency of pulse input exceeds the maximum speed of the motor |
| AL.250 | Braking without feedback<br>The brake feedback circuit of the Driver is abnormal. Replace the Driver or contact after-sales service.  |
| AL.251 | Braking timeout<br>Please connect the braking resistor or check whether the resistance of the braking resistor is normal<br>Please check whether the input AC voltage is within the calibrated working voltage range of the Driver              |
| AL.252 | Limit input abnormal<br>Because the positive and negative limits take effect at the same time, please check the limit sensor and its input port polarity settings   |
| AL.253 | Braking voltage setting value is too large<br>Please check whether the parameter setting value of P01.27 meets the requirements of the manual   |
| AL.260 | Analog input channel 1 zero drift setting is abnormal   |
| AL.261 | Analog input channel 2 zero drift setting is abnormal   |

### 7.3 Relationship between LED indication and fault code

| LED indication | LED fault description                     | Error code   |
|----------------|---|--|
| Steady green   | Driver is not enabled                     | 0  |
| Flashing green | Driver enable, normal working state       | 0  |
| 1 green 1 red  | Driver overcurrent                        | 110、111  |
| 1 green 2 red  | Driver overvoltage                        | 210、212  |
| 1 green 3 red  | Driver internal voltage error             | 115  |
| 1 green 4 red  | Encoder out of tolerance alarm            | 140、240、291  |
| 1 green 5 red  | Driver undervoltage                       | 211  |
| 1 green 6 red  | Parameter storage error                   | 100、101  |
| 1 green 7 red  | Braking abnormality (no feedback/timeout) | 250、251、253  |
| 1 green 8 red  | Encoder failure                           | 105、120、121、128、162、163、164、165、166、167、168、169、170、174、175、190、191、220、221、222、 |
| 1 green 9 red  | Limit input error warning                 | 252  |
| 1 green 10 red | Motor thermal overload warning            | 113  |
| 1 green 11 red | Motor command overload warning            | 112  |
| 1 green 12 red | Motor output saturation timeout warning   | 231  |

|                |                                    |                   |
|----------------|------------------------------------|-------------------|
| 1 green 13 red | CAN bus failure                    | 261、262、263、264   |
| 1 green 14 red | CAN bus disconnection              | 265               |
| 1 green 15 red | The software is running abnormally | 103               |
| 1 green 17 red | Other undefined                    | Other fault codes |

## Chapter 8 Chapter 8 Appendix

### Appendix B List of servo parameters

#### Group P00 Servo Driver/motor parameters

| Parameter number | Name   | Predetermined area | Unit              | Factory setting | Related patterns |
|------------------|--|--------------------|-------------------|-----------------|------------------|
| P00.00           | Motor number                                     | 10000~65535        | -                 | 50604           | -                |
| P00.01           | Servo Driver model                               | -                  | -                 | -               | Show             |
| P00.02           | MCU software version number                      | -                  | -                 | -               | Show             |
| P00.03           | FPGA software version                            | -                  | -                 | -               | Show             |
| P00.04           | EtherCAT software version                        | -                  | -                 | -               | Show             |
| P00.05           | Driver hardware version                          | -                  | -                 | -               | Show             |
| P00.06           | CAN software version                             | -                  | -                 | -               | Show             |
| P00.07           | Software non-standard ID number                  | -                  | -                 | -               | Show             |
| P00.08           | Hardware non-standard ID number                  | -                  | -                 | -               | Show             |
| P00.09           | Driver PWM update mode                           | -                  | -                 | -               | Show             |
| P00.17           | rated power                                      | 1~65535            | 0.01KW            | -               | -                |
| P00.18           | Rated voltage                                    | 1~380              | V                 | -               | -                |
| P00.19           | Rated current                                    | 1~65535            | 0.1A              | -               | -                |
| P00.20           | Rated speed                                      | 1~6000             | rpm               | -               | -                |
| P00.21           | Maximum speed                                    | 1~6000             | rpm               | -               | -                |
| P00.22           | Rated torque                                     | 1~65535            | 0.01Nm            | -               | -                |
| P00.23           | Maximum torque                                   | 1~65535            | 0.01Nm            | -               | -                |
| P00.24           | Moment of inertia Jm                             | 1~65535            | kgcm <sup>2</sup> | -               | -                |
| P00.25           | Number of motor pole pairs                       | 2~360              | pole pairs        | -               | -                |
| P00.26           | Stator resistance                                | 1~65535            | 0.001Ω            | -               | -                |
| P00.27           | Stator inductance Lq                             | 1~65535            | 0.01mH            | -               | -                |
| P00.28           | Stator inductance Ld                             | 1~65535            | 0.01mH            | -               | -                |
| P00.29           | Linear back-EMF coefficient                      | 1~65535            | 0.01mV/rpm        | -               | -                |
| P00.30           | Torque coefficient Kt                            | 1~65535            | 0.01Nm/Arms       | -               | -                |
| P00.31           | Electrical time constant Te                      | 1~65535            | 0.01ms            | -               | -                |
| P00.32           | Mechanical time constant Tm                      | 1~65535            | 0.01ms            | -               | -                |
| P00.34           | Encoder type                                     | 0~4                | -                 | 2               | -                |
| P00.35<br>P00.36 | Absolute encoder offset                          | 0~1073741824       | P                 | 0               | -                |
| P00.37           | Absolute encoder digits                          | 10~23              | 位                 | 17              | -                |
| P00.38           | Incremental encoder pulse number                 | 1000~65535         | P/r               | 10000           | -                |
| P00.39           | Encoder Z phase signal offset                    | 0~65535            | P                 | 1250            | -                |
| P00.40           | Encoder U phase signal rising edge offset        | 0~65535            | P                 | 0               | -                |
| P00.41           | Prohibit multi-turn encoder battery fault output | 0~1                | -                 | 0               | -                |



|                  |  |                    |       |        |      |
|------------------|--|--------------------|-------|--------|------|
| P00.42           | Multi-turn encoder multi-turn bits   | 0~24               | 位     | 16     | -    |
| P00.43           | Driver power-on position calibration torque  | 0~100              | %     | 90     | -    |
| P00.44           | Set current position as mechanical zero  | 0~1                | -     | 0      | -    |
| P00.45<br>P00.46 | Encoder single-turn value corresponding to the mechanical zero of the absolute value system    | 0~16777216         | P     | 0      | -    |
| P00.47<br>P00.48 | The encoder multi-turn value corresponding to the mechanical zero of the absolute value system | -16777216~16777216 | Cycle | 0      | -    |
| P00.49           | It is forbidden to use the absolute encoder position to update the current position command    | 0~1                | -     | 0      | -    |
| P00.50<br>P00.51 | Divided output gear ratio numerator  | 1~8388608          | -     | 10000  | -    |
| P00.52<br>P00.53 | Frequency division output gear ratio denominator   | 1~8388608          | -     | 131072 | -    |
| P00.54           | Exchange frequency division output AB phase pulse  | 0~1                | -     | 0      | -    |
| P00.55           | Encoder EEPROM version number  | -                  | -     | -      | Show |
| P00.56           | Rotation mode enable/divide frequency output Z phase width                                     | 0~1(1~65535)       | -     | 0(8)   | -    |
| P00.57           | Frequency division output Z phase signal polarity  | 0~1                | -     | 0      | -    |
| P00.58           | Frequency division output Z phase initialization mode  | 0~1                | -     | 0      | -    |

## Group P01 Basic control parameters

| Parameter number | Name  | Predetermined area | Unit | Factory setting | Related patterns |
|------------------|---|--------------------|------|-----------------|------------------|
| P01.00           | Control mode selection  | 0~7                | -    | 0               | -                |
| P01.01           | Rotation direction selection                                  | 0~1                | -    | 0               | -                |
| P01.20           | The minimum value of braking resistance allowed by the Driver | -                  | Ω    | -               | Show             |
| P01.21           | Built-in braking resistor power                               | -                  | W    | -               | Show             |
| P01.22           | Built-in braking resistor resistance                          | -                  | Ω    | -               | Show             |
| P01.23           | Resistance heat dissipation coefficient                       | 1~100              | %    | 20              | -                |
| P01.24           | Braking resistance setting                                    | 0~1                | -    | 0               | -                |
| P01.25           | External braking resistor power                               | 1~65535            | W    | 50              | -                |
| P01.26           | Resistance of external braking resistor                       | 1~1000             | Ω    | 10              | -                |
| P01.27           | Braking start voltage value                                   | 1~100              |      | 68              | -                |
| P01.28           | Brake feedback detection mode (do not set)                    | 0~1                |      | 1               | -                |
| P01.29           | Maximum continuous braking time                               | 1~1000             | ms   | 3000            | -                |
| P01.33           | Emergency stop deceleration time constant                     | 1~65535            | ms   | 5               | -                |
| P01.36           | Servo enable delay off time                                   | 0~65535            | ms   | 50              | -                |
| P01.37           | Speed regulator saturation detection time                     | 0~65535            | 10ms | 450             | -                |

|        |  |         |      |     |   |
|--------|--|---------|------|-----|---|
| P01.42 | Instruction overload start detection point | 0~300   | %    | 100 | - |
| P01.43 | Command overload peak detection point      | 0~300   | %    | 300 | - |
| P01.44 | Command overload detection time            | 0~65535 | 10ms | 450 | - |
| P01.45 | Thermal overload initial detection point   | 0~300   | %    | 100 | - |
| P01.46 | Thermal overload peak detection point      | 0~300   | %    | 300 | - |
| P01.47 | Thermal overload detection time            | 0~65535 | 10ms | 450 | - |
| P01.48 | Overvoltage detection threshold            | 1~100   | V    | 85  | - |
| P01.49 | Undervoltage detection threshold           | 1~100   | V    | 15  | - |

## Group P02 Terminal input/output parameters

| Parameter number | Name                              | Predetermined area | Unit | Factory setting | Related patterns |
|------------------|-----------------------------------|--------------------|------|-----------------|------------------|
| P02.00           | IN1 terminal function selection   | 0~31               | -    | 1               | -                |
| P02.01           | IN1 terminal logic selection      | 0~1                | -    | 0               | -                |
| P02.02           | IN2 terminal function selection   | 0~31               | -    | 5               | -                |
| P02.03           | IN2 terminal logic selection      | 0~1                | -    | 0               | -                |
| P02.04           | IN3 terminal function selection   | 0~31               | -    | 6               | -                |
| P02.05           | IN3 terminal logic selection      | 0~1                | -    | 0               | -                |
| P02.06           | IN4 terminal function selection   | 0~31               | -    | 23              | -                |
| P02.07           | IN4 terminal logic selection      | 0~1                | -    | 0               | -                |
| P02.08           | IN5 terminal function selection   | 0~31               | -    | 0               | -                |
| P02.09           | IN5 terminal logic selection      | 0~1                | -    | 0               | -                |
| P02.10           | IN6 terminal function selection   | 0~31               | -    | 0               | -                |
| P02.11           | IN6 terminal logic selection      | 0~1                | -    | 0               | -                |
| P02.12           | IN7 terminal function selection   | 0~31               | -    | 0               | -                |
| P02.13           | IN7 terminal logic selection      | 0~1                | -    | 0               | -                |
| P02.14           | IN8 terminal function selection   | 0~31               | -    | 0               | -                |
| P02.15           | IN8 terminal logic selection      | 0~1                | -    | 0               | -                |
| P02.16           | IN9 terminal function selection   | 0~31               | -    | 0               | -                |
| P02.17           | IN9 terminal logic selection      | 0~1                | -    | 0               | -                |
| P02.32           | OUT1 terminal function selection  | 0~31               | -    | 1               | -                |
| P02.33           | OUT1 terminal logic selection     | 0~1                | -    | 0               | -                |
| P02.34           | OUT2 terminal function selection  | 0~31               | -    | 6               | -                |
| P02.35           | OUT2 terminal logic selection     | 0~1                | -    | 0               | -                |
| P02.36           | OUT3 terminal function selection  | 0~31               | -    | 0               | -                |
| P02.37           | OUT3 terminal logic selection     | 0~1                | -    | 0               | -                |
| P02.52           | IN terminal is forcibly effective | 0~65535            | -    | 0               | -                |
| P02.53           | OUT terminal forced effective     | 0~65535            | -    | 0               | -                |
| P02.54<br>P02.55 | FunIN function valid flag         | -                  | -    | -               | Show             |

|                  |   |         |   |   |      |
|------------------|---|---------|---|---|------|
| P02.56<br>P02.57 | The rising edge of the FunIN function latches the valid flag  | -       | - | - | Show |
| P02.58<br>P02.59 | The falling edge of the FunIN function latches the valid flag | -       | - | - | Show |
| P02.60<br>P02.61 | FunOUT function valid flag                                    | -       | - | - | Show |
| P02.62           | Physical output enable  | 0~65535 | - | 0 | -    |
| P02.63           | Physical output status  | 0~65535 | - | 0 | -    |

## Group P03 Position control parameters

| Parameter number | Name   | Predetermined area     | Unit             | Factory setting | Related patterns |
|------------------|--|------------------------|------------------|-----------------|------------------|
| P03.00           | Position command source  | 0~10                   | -                | 0               | P                |
| P03.02           | Pulse command type selection   | 0~3                    | -                | 0               | P                |
| P03.03           | Reserve  | -                      | -                | -               | -                |
| P03.04           | Position command average filter time constant  | 1~2048                 | 0.1ms            | 1               | P                |
| P03.05           | Position command first-order low-pass filter time constant                           | 0~65535                | 0.1ms            | 0               | P                |
| P03.06<br>P03.07 | Number of position commands for one motor rotation                                   | 0~8388608              | P/r              | 10000           | P                |
| P03.08<br>P03.09 | Electronic gear ratio numerator 1  | 1~1073741824           | -                | 1               | P                |
| P03.10<br>P03.11 | Electronic gear ratio denominator 1  | 1~1073741824           | -                | 1               | P                |
| P03.12<br>P03.13 | Electronic gear ratio numerator 2  | 1~1073741824           | -                | 1               | P                |
| P03.14<br>P03.15 | Electronic gear ratio denominator 2  | 1~1073741824           | -                | 1               | P                |
| P03.20           | In-position signal establishment time  | 0~65535                | 0.1ms            | 10              | P                |
| P03.21           | Position command stop detection time   | 0~65535                | 0.1ms            | 10              | P                |
| P03.22           | Positioning completion threshold   | 1~65535                | Coding unit      | 10              | P                |
| P03.23           | Clear position deviation action selection  | 0~1                    | -                | 0               | P                |
| P03.24           | Position deviation fault detection prohibited  | 0~1                    | -                | 0               | P                |
| P03.25<br>P03.26 | Position deviation fault detection threshold   | 1~1073741824           | Coding unit      | 1310720         | P                |
| P03.27           | Reserve  | -                      | -                | -               | -                |
| P03.28           | Stepping operation command pulse number  | -1073741824~1073741824 | Instruction unit | 10000           | P                |
| P03.30           | Stepping speed   | 0~6000                 | rpm              | 1000            | P                |
| P03.31           | Stepping operation acceleration time constant  | 1~65535                | 1ms              | 200             | P                |
| P03.32           | Stepping operation deceleration time constant  | 1~65535                | 1ms              | 200             | P                |
| P03.40           | Home position return enable control  | 0~6                    | -                | 1               | P                |
| P03.41           | Home position return mode selection  | 0~13                   | -                | 0               | P                |
| P03.42           | High-speed search for the speed of the origin switch signal                          | 0~3000                 | rpm              | 100             | P                |
| P03.43           | Low speed search origin switch signal speed  | 0~1000                 | rpm              | 50              | P                |
| P03.44           | Search for the acceleration and deceleration time constant of the zero switch signal | 1~65535                | ms               | 100             | P                |

|                  |  |                        |                  |       |   |
|------------------|--|------------------------|------------------|-------|---|
| P03.45           | Reserve  | -                      | -                | -     | - |
| P03.46<br>P03.47 | Machine origin offset  | -1073741824~1073741824 | -                | 0     | P |
| P03.49           | Mechanical origin offset and limit processing method             | 0~3                    | -                | 0     | P |
| P03.50           | Threshold for the time to return to zero when touched down       | 0~65535                | ms               | 100   | P |
| P03.51           | Threshold for the speed of zero return to zero when touched down | 0~1000                 | rpm              | 10    | P |
| P03.52           | Touch stop and return to zero torque limit                       | 0~100                  | %                | 50    | P |
| P03.53           | Communication control position command type                      | 0~1                    | -                | 0     | P |
| P03.54           | Communication control acceleration time constant                 | 1~65535                | ms               | 100   | P |
| P03.55           | Communication control deceleration time constant                 | 1~65535                | ms               | 100   | P |
| P03.56           | Communication control operating speed                            | 0~6000                 | rpm              | 500   | P |
| P03.57<br>P03.58 | Communication control position command                           | -1073741824~1073741824 | Instruction unit | 10000 | P |

## Group P04 Speed control parameters

| Parameter number | Name   | Predetermined area | Unit             | Factory setting | Related patterns |
|------------------|--|--------------------|------------------|-----------------|------------------|
| P04.00           | Speed command source selection               | 0~10               | -                | 0               | S                |
| P04.01           | Speed command digital set value              | -6000~6000         | rpm              | 1000            | S                |
| P04.02           | Analog input channel settings                | 0~1                | -                | 0               | S                |
| P04.04           | Jog speed setting value                      | 0~6000             | rpm              | 1000            | S                |
| P04.05           | Speed command acceleration time constant     | 1~65535            | ms               | 200             | S                |
| P04.06           | Speed command deceleration time constant     | 1~65535            | ms               | 200             | S                |
| P04.07           | Zero speed clamp speed threshold             | 0~3000             | rpm              | 10              | S                |
| P04.14           | Speed reaches the detection threshold        | 0~6000             | rpm              | 1000            | S                |
| P04.15           | Reserve                                      | -                  | -                | -               | -                |
| P04.16           | Speed mode jog forward speed                 | 0~6000             | rpm              | 200             | S                |
| P04.17           | Speed mode jog reversal speed                | 0~6000             | rpm              | 200             | S                |
| P04.18           | Speed mode jog acceleration time constant    | 1~65535            | ms               | 100             | S                |
| P04.19           | Speed mode jog deceleration time constant    | 1~65535            | ms               | 100             | S                |
| P04.20           | Position mode jog forward speed              | 0~6000             | rpm              | 200             | S                |
| P04.21           | Position mode jog reversal speed             | 0~6000             | rpm              | 200             | S                |
| P04.22           | Position mode jog acceleration time constant | 1~65535            | ms               | 100             | S                |
| P04.23           | Position mode jog deceleration time constant | 1~65535            | ms               | 100             | S                |
| P04.24<br>P04.25 | Fixed-length stroke in position mode         | 0~1073741824       | Instruction unit | 10000           | P                |
| P04.60           | Communication control command pulse number   | 0~1073741824       | P                | 50000           | S                |
| P04.62           | Communication control speed                  | 0~6000             | rpm              | 1000            | S                |

|        |   |         |       |     |      |
|--------|---|---------|-------|-----|------|
| P04.63 | Communication control acceleration time constant  | 1~65535 | ms    | 200 | S    |
| P04.64 | Communication control deceleration time constant  | 1~65535 | ms    | 200 | S    |
| P04.65 | Communication control operation mode              | 0~1     | -     | 0   | S    |
| P04.66 | Communication control operation start direction   | 0~1     | -     | 0   | S    |
| P04.67 | Communication control operation times             | 0~65535 | -     | 0   | S    |
| P04.68 | Open loop running speed                           | 0~3000  | rpm   | 100 | -    |
| P04.69 | Open loop running acceleration                    | 1~100   | r/s^2 | 10  | -    |
| P04.70 | Open loop running deceleration                    | 1~100   | r/s^2 | 10  | -    |
| P04.71 | Open loop operating torque                        | 0~100   | %     | 50  | -    |
| P04.72 | Open loop operation start and stop instructions   | 0~6     | -     | 0   | -    |
| P04.73 | Lock shaft position                               | 0~65535 | -     | 0   | -    |
| P04.74 | Lock shaft torque                                 | 0~100   | %     | 50  | -    |
| P04.75 | Lock shaft start and stop command                 | 0~1     | -     | 0   | -    |
| P04.76 | Encoder calibration speed                         | 1~100   | rpm   | 10  | -    |
| P04.77 | Encoder calibration acceleration                  | 1~10    | r/s^2 | 1   | -    |
| P04.78 | Encoder calibration deceleration                  | 1~10    | r/s^2 | 1   | -    |
| P04.79 | Encoder calibration torque                        | 0~100   | %     | 85  | -    |
| P04.80 | Encoder calibration start instruction             | 0~1     | -     | 0   | -    |
| p04.81 | Encoder receiving insufficient data fault counter | -       | -     | -   | Show |
| P04.82 | Encoder receiving disconnection fault counter     | -       | -     | -   | Show |
| P04.83 | Encoder receiving CRC failure counter             | -       | -     | -   | Show |
| P04.84 | Encoder receiver module failure counter           | -       | -     | -   | Show |
| P04.85 | Encoder receiving continuous fault counter        | -       | -     | -   | Show |

### Group P05 Torque control parameters

| Parameter number | Name                                      | Predetermined area | Unit   | Factory setting | Related patterns |
|------------------|---|--------------------|--------|-----------------|------------------|
| P05.00           | Torque command source A                   | 0~2                | -      | 0               | T                |
| P05.01           | Torque command source B                   | 0~2                | -      | 0               | T                |
| P05.02           | Torque command source                     | 0~3                | -      | 0               | T                |
| P05.03           | Torque command digital set value          | -3000~3000         | 0.1%   | 200             | T                |
| P05.04           | Driver overload factor                    | 0~3000             | 0.1%   | 3000            | T                |
| P05.05           | Torque ramp                               | 1~65535            | 0.1%/s | 3000            | T                |
| P05.06           | Torque limit source (reserved)            | 0~4                | -      | 0               | T                |
| P05.07           | Torque limit source AI channel (reserved) | 0~1                | -      | 0               | T                |
| P05.08           | Internal forward torque limit (reserved)  | 0~3000             | 0.1%   | 3000            | T                |
| P05.09           | Internal negative torque limit (reserved) | 0~3000             | 0.1%   | 3000            | T                |
| P05.10           | External forward torque limit             | 0~3000             | 0.1%   | 3000            | T                |

|        |   |         |      |      |   |
|--------|---|---------|------|------|---|
|        | (reserved)  |         |      |      |   |
| P05.11 | External negative torque limit (reserved)         | 0~3000  | 0.1% | 3000 | T |
| P05.12 | Source of speed limit                             | 0~1     | -    | 0    | T |
| P05.13 | Speed limit analog channel source (reserved)      | 0~1     | -    | 0    | T |
| P05.14 | Torque control forward speed limit value          | 0~6000  | rpm  | 3000 | T |
| P05.15 | Torque control negative speed limit value         | 0~6000  | rpm  | 0    | T |
| P05.16 | Torque reaches the reference value                | 0~65535 | 0.1% | 0    | T |
| P05.17 | Torque reaches effective value                    | 0~65535 | 0.1% | 100  | T |
| P05.18 | Torque reaches invalid value                      | 0~65535 | 0.1% | 50   | T |
| P05.19 | Effective detection time of torque arrival signal | 0~65535 | Ms   | 50   | T |
| P05.20 | Communication given torque command                | 0~3000  | 0.1% | 200  | T |
| P05.21 | Torque running acceleration time constant         | 1~65535 | ms   | 100  | T |
| P05.22 | Torque running deceleration time constant         | 1~65535 | ms   | 100  | T |
| P05.23 | Torque holding time                               | 0~65535 | ms   | 500  | T |
| P05.24 | Working mode after torque is reached              | 0~3     | -    | 0    | T |
| P05.25 | Communication triggers torque operation           | 0~2     | -    | 0    | T |
| P05.33 | Torque limit detection time (reserved)            | 0~65535 | -    | 0    | T |
| P05.34 | Reserve   | -       | -    | -    | T |
| P05.35 | Reserve   | -       | -    | -    | T |
| P05.36 | Reserve   | -       | -    | -    | T |
| P05.37 | Reserve   | -       | -    | -    | T |

## Group P06 Gain parameters

| Parameter number | Name  | Predetermined area | Unit  | Factory setting | Related patterns |
|------------------|---|--------------------|-------|-----------------|------------------|
| P06.00           | 1st speed gain                                      | 0~65535            | 0.1Hz | 4500            | -                |
| P06.01           | 1st speed integral time constant                    | 1~30000            | 0.1ms | 3500            | -                |
| P06.02           | 1st position gain                                   | 0~5000             | 0.1Hz | 500             | -                |
| P06.03           | 2nd speed gain                                      | 0~65535            | 0.1Hz | 4500            | -                |
| P06.04           | 2nd speed integral time constant                    | 1~30000            | 0.1ms | 3500            | -                |
| P06.05           | 2nd position gain                                   | 0~5000             | 0.1Hz | 500             | -                |
| P06.06           | Skd   | 0~65535            | -     | 0               | -                |
| P06.07           | Skr   | 0~65535            | -     | 1000            | -                |
| P06.08           | Skm   | 0~65535            | -     | 0               | -                |
| P06.09           | Pki   | 0~65535            | -     | 0               | -                |
| P06.10           | Pkd   | 0~65535            | -     | 0               | -                |
| P06.14           | Speed feedforward low-pass filter cut-off frequency | 0~10000            | Hz    | 2000            | -                |
| P06.15           | Speed feedforward gain                              | 0~1000             | 0.1%  | 0               | -                |
| P06.16           | Torque feedforward low-pass                         | 0~10000            | Hz    | 2000            | -                |

|        |  |         |       |      |   |
|--------|--|---------|-------|------|---|
|        | filter cut-off frequency                                     |         |       |      |   |
| P06.17 | Torque feedforward gain                                      | 0~1000  | 0.1%  | 0    | - |
| P06.18 | Reserve  | -       | -     | -    | - |
| P06.19 | Speed low pass filter cut-off frequency 1                    | 0~10000 | Hz    | 1000 | - |
| P06.20 | Speed low pass filter cut-off frequency 2                    | 0~10000 | Hz    | 2000 | - |
| P06.21 | Reserve  | -       | -     | -    | - |
| P06.24 | Torque command low-pass filter cut-off frequency 1           | 0~10000 | Hz    | 1000 | - |
| P06.25 | Reserve  | -       | -     | -    | - |
| P06.26 | Torque feedback low-pass filter cut-off frequency 1          | 0~10000 | Hz    | 1000 | - |
| P06.27 | Reserve  | -       | -     | -    | - |
| P06.28 | Current loop proportional gain                               | 0~50000 | Hz    | 1000 | - |
| P06.29 | Current loop integral time constant                          | 0~10000 | 0.1ms | 1500 | - |
| P06.30 | PVIA proportional gain KP                                    | 0~50000 | -     | 3000 | - |
| P06.31 | PVIA integral gain KI  | 0~10000 | -     | 1000 | - |
| P06.32 | PVIA speed gain KV1  | 0~50000 | -     | 1000 | - |
| P06.33 | PVIA speed gain KV2  | 0~50000 | -     | 100  | - |
| P06.34 | PVIA acceleration gain KA                                    | 0~50000 | -     | 0    | - |
| P06.35 | PVIA speed gain KVFF   | 0~50000 | -     | 1000 | - |
| P06.36 | PVIA acceleration gain KAFF                                  | 0~50000 | -     | 0    | - |
| P06.37 | PVIA command speed low-pass filter cut-off frequency         | 1~10000 | Hz    | 1000 | - |
| P06.38 | PVIA command acceleration low-pass filter cut-off frequency  | 1~10000 | Hz    | 2000 | - |
| P06.39 | PVIA feedback acceleration low-pass filter cut-off frequency | 1~10000 | Hz    | 2000 | - |
| P06.40 | PVIA enable control  | 0~25    | -     | 0    | - |
| P06.45 | Reserve  | -       | -     | -    | - |
| P06.46 | Reserve  | -       | -     | -    | - |
| P06.47 | Reserve  | -       | -     | -    | - |
| P06.48 | Reserve  | -       | -     | -    | - |
| P06.49 | Reserve  | -       | -     | -    | - |
| P06.50 | Reserve  | -       | -     | -    | - |
| P06.51 | Reserve  | -       | -     | -    | - |
| P06.52 | Reserve  | -       | -     | -    | - |
| P06.53 | Reserve  | -       | -     | -    | - |

### Group P08 Communication parameters

| Parameter number | Name  | Predetermined area | Unit | Factory setting | Related patterns |
|------------------|---|--------------------|------|-----------------|------------------|
| P08.00           | RS485 communication axis address                    | 1~247              | -    | 1               | -                |
| P08.01           | RS485 communication serial port baud rate selection | 0~5                | -    | 5               | -                |
| P08.02           | RS485 communication data format selection           | 0~5                | -    | 0               | -                |

|         |  |         |    |   |      |
|---------|--|---------|----|---|------|
| P08.05  | CAN communication axis address                       | 1~127   | -  | 2 | -    |
| P08.06  | CAN communication baud rate selection                | 0~6     | -  | 4 | -    |
| P08.07  | CAN disconnection detection time                     | 0~65535 | ms | 0 | -    |
| P08.08  | Station address assigned by the EtherCAT host        | -       | -  | - | Show |
| P08.09  | Display the current site alias address of the Driver | -       | -  | - | Show |
| P08.10  | Set the EtherCAT communication station of the Driver | 0~65535 | -  | 0 | -    |
| P08.30  | RS232 communication axis address                     | Show    | -  | 1 | -    |
| P083.31 | RS232 communication serial port baud rate selection  | 0~5     | -  | 5 | -    |
| P08.32  | RS323 communication data format selection            | 0~5     | -  | 0 | -    |

### Group P09 Multi-segment position parameters

| Parameter number | Name  | Predetermined area     | Unit             | Factory setting | Related patterns |
|------------------|---|------------------------|------------------|-----------------|------------------|
| P09.00           | Multi-stage position operation mode                                     | 0~2                    | -                | 1               | P                |
| P09.01           | Number of end segments of position command                              | 0~16                   | -                | 1               | P                |
| P09.03           | Time unit selection   | 0~1                    | -                | 0               | P                |
| P09.04           | Position command type selection   | 0~1                    | -                | 0               | P                |
| P09.12<br>P09.13 | 1st position command  | -1073741824~1073741824 | Instruction unit | 10000           | P                |
| P09.14           | Maximum operating speed of stage 1                                      | 1~6000                 | rpm              | 200             | P                |
| P09.15           | 1st stage position command acceleration/deceleration time constant      | 1~65535                | ms               | 100             | P                |
| P09.16           | Waiting time after the completion of the first segment position command | 0~65535                | ms(s)            | 100             | P                |
| P09.17<br>P09.18 | 2nd position command  | -1073741824~1073741824 | Instruction unit | 10000           | P                |
| P09.19           | Maximum operating speed of stage 2                                      | 1~6000                 | rpm              | 200             | P                |
| P09.20           | 2nd stage position command acceleration and deceleration time constant  | 1~65535                | ms               | 100             | P                |
| P09.21           | Waiting time after the completion of the second position command        | 0~65535                | ms(s)            | 100             | P                |
| P09.22<br>P09.23 | 3rd position command  | -1073741824~1073741824 | Instruction unit | 10000           | P                |
| P09.24           | Maximum operating speed of stage 3                                      | 1~6000                 | rpm              | 200             | P                |
| P09.25           | 3rd step position command acceleration and deceleration time constant   | 1~65535                | ms               | 100             | P                |
| P09.26           | Waiting time after the completion of the 3rd position command           | 0~65535                | ms(s)            | 100             | P                |
| P09.27<br>P09.28 | 4th position command  | -1073741824~1073741824 | Instruction unit | 10000           | P                |
| P09.29           | Maximum operating speed of stage 4                                      | 1~6000                 | rpm              | 200             | P                |
| P09.30           | The 4th step position command acceleration and deceleration             | 1~65535                | ms               | 100             | P                |



|                  |  |                        |                  |       |   |
|------------------|--|------------------------|------------------|-------|---|
|                  | time constant  |                        |                  |       |   |
| P09.31           | Waiting time after the completion of the 4th position command              | 0~65535                | ms(s)            | 100   | P |
| P09.32<br>P09.33 | 5th position command   | -1073741824~1073741824 | Instruction unit | 10000 | P |
| P09.34           | Maximum operating speed of stage 5   | 1~6000                 | rpm              | 200   | P |
| P09.35           | 5th step position command acceleration and deceleration time constant      | 1~65535                | ms               | 100   | P |
| P09.36           | Waiting time after the completion of the 5th position command              | 0~65535                | ms(s)            | 100   | P |
| P09.37<br>P09.38 | 6th position command   | -1073741824~1073741824 | Instruction unit | 10000 | P |
| P09.39           | Maximum operating speed of stage 6   | 1~6000                 | rpm              | 200   | P |
| P09.40           | The 6th stage position command acceleration and deceleration time constant | 1~65535                | ms               | 100   | P |
| P09.41           | Waiting time after the completion of the 6th position command              | 0~65535                | ms(s)            | 100   | P |
| P09.42<br>P09.43 | 7th position command   | -1073741824~1073741824 | Instruction unit | 10000 | P |
| P09.44           | Maximum operating speed of stage 7   | 1~6000                 | rpm              | 200   | P |
| P09.45           | 7th stage position command acceleration and deceleration time constant     | 1~65535                | ms               | 100   | P |
| P09.46           | Waiting time after the completion of the 7th segment position command      | 0~65535                | ms(s)            | 100   | P |
| P09.47<br>P09.48 | 8th position command   | -1073741824~1073741824 | Instruction unit | 10000 | P |
| P09.49           | Maximum operating speed of section 8                                       | 1~6000                 | rpm              | 200   | P |
| P09.50           | 8th step position command acceleration and deceleration time constant      | 1~65535                | ms               | 100   | P |
| P09.51           | Waiting time after the 8th segment position command is completed           | 0~65535                | ms(s)            | 100   | P |
| P09.52<br>P09.53 | 9th position command   | -1073741824~1073741824 | Instruction unit | 10000 | P |
| P09.54           | Maximum operating speed of stage 9   | 1~6000                 | rpm              | 200   | P |
| P09.55           | 9th stage position command acceleration and deceleration time constant     | 1~65535                | ms               | 100   | P |
| P09.56           | Waiting time after the 9th segment position command is completed           | 0~65535                | ms(s)            | 100   | P |
| P09.57<br>P09.58 | 10th position command  | -1073741824~1073741824 | Instruction unit | 10000 | P |
| P09.59           | 10th stage maximum operating speed   | 1~6000                 | rpm              | 200   | P |
| P09.60           | 10th stage position command acceleration and deceleration time constant    | 1~65535                | ms               | 100   | P |
| P09.61           | Waiting time after the completion of the 10th position command             | 0~65535                | ms(s)            | 100   | P |
| P09.62<br>P09.63 | 11th position command  | -1073741824~1073741824 | Instruction unit | 10000 | P |
| P09.64           | 11th stage maximum operating speed   | 1~6000                 | rpm              | 200   | P |
| P09.65           | The 11th step position command acceleration and                            | 1~65535                | ms               | 100   | P |

|                  |  |                        |                  |       |   |
|------------------|--|------------------------|------------------|-------|---|
|                  | deceleration time constant   |                        |                  |       |   |
| P09.66           | Waiting time after the completion of the 11th position command             | 0~65535                | ms(s)            | 100   | P |
| P09.67<br>P09.68 | 12th position command  | -1073741824~1073741824 | Instruction unit | 10000 | P |
| P09.69           | 12th stage maximum operating speed   | 1~6000                 | rpm              | 200   | P |
| P09.70           | 12th stage position command acceleration and deceleration time constant    | 1~65535                | ms               | 100   | P |
| P09.71           | Waiting time after the completion of the 12th position command             | 0~65535                | ms(s)            | 100   | P |
| P09.72<br>P09.73 | 13th position command  | -1073741824~1073741824 | Instruction unit | 10000 | P |
| P09.74           | 13th stage maximum operating speed   | 1~6000                 | rpm              | 200   | P |
| P09.75           | 13th stage position command acceleration and deceleration time constant    | 1~65535                | ms               | 100   | P |
| P09.76           | Waiting time after the completion of the 13th position command             | 0~65535                | ms(s)            | 100   | P |
| P09.77<br>P09.78 | 14th position command  | -1073741824~1073741824 | Instruction unit | 10000 | P |
| P09.79           | Maximum operating speed of stage 14  | 1~6000                 | rpm              | 200   | P |
| P09.80           | The 14th step position command acceleration and deceleration time constant | 1~65535                | ms               | 100   | P |
| P09.81           | Waiting time after the 15th segment position command is completed          | 0~65535                | ms(s)            | 100   | P |
| P09.82<br>P09.83 | 15th position command  | -1073741824~1073741824 | Instruction unit | 10000 | P |
| P09.84           | 15th stage maximum operating speed   | 1~6000                 | rpm              | 200   | P |
| P09.85           | 15th stage position command acceleration and deceleration time constant    | 1~65535                | ms               | 100   | P |
| P09.86           | Waiting time after the 15th segment position command is completed          | 0~65535                | ms(s)            | 100   | P |
| P09.87<br>P09.88 | 16th position command  | -1073741824~1073741824 | Instruction unit | 10000 | P |
| P09.89           | Maximum operating speed of stage 16  | 1~6000                 | rpm              | 200   | P |
| P09.90           | 16th stage position command acceleration and deceleration time constant    | 1~65535                | ms               | 100   | P |
| P09.91           | Waiting time after the 16th segment position command is completed          | 0~65535                | ms(s)            | 100   | P |

### Group P10 Multi-segment speed parameters

| Parameter number | Name                                     | Predetermined area | Unit | Factory setting | Related patterns |
|------------------|--|--------------------|------|-----------------|------------------|
| P10.00           | Multi-stage speed command operation mode | 0~2                | -    | 1               | S                |
| P10.01           | Speed command end point number           | 0~16               | -    | 16              | S                |
| P10.02           | Running time unit                        | 0~1                | -    | 0               | S                |
| P10.03           | Acceleration time constant 1             | 1~65535            | ms   | 200             | S                |

|        |   |            |                  |     |   |
|--------|---|------------|------------------|-----|---|
| P10.04 | Deceleration time constant 1                                    | 1~65535    | ms               | 200 | S |
| P10.05 | Acceleration time constant 2                                    | 1~65535    | ms               | 200 | S |
| P10.06 | Deceleration time constant 2                                    | 1~65535    | ms               | 200 | S |
| P10.07 | Acceleration time constant 3                                    | 1~65535    | ms               | 200 | S |
| P10.08 | Deceleration time constant 3                                    | 1~65535    | ms               | 200 | S |
| P10.09 | Acceleration time constant 4                                    | 1~65535    | ms               | 200 | S |
| P10.10 | Deceleration time constant 4                                    | 1~65535    | ms               | 200 | S |
| P10.11 | Acceleration time constant 5                                    | 1~65535    | ms               | 200 | S |
| P10.12 | Deceleration time constant 5                                    | 1~65535    | ms               | 200 | S |
| P10.13 | Acceleration time constant 6                                    | 1~65535    | ms               | 200 | S |
| P10.14 | Deceleration time constant 6                                    | 1~65535    | ms               | 200 | S |
| P10.15 | Acceleration time constant 7                                    | 1~65535    | ms               | 200 | S |
| P10.16 | Deceleration time constant 7                                    | 1~65535    | ms               | 200 | S |
| P10.20 | 1st stage speed command   | -6000~6000 | rpm              | 100 | S |
| P10.21 | 1st stage speed command running time                            | 0~65535    | 0.1sec<br>0.1min | 10  | S |
| P10.22 | 1st stage acceleration and deceleration time constant selection | 1~7        | -                | 1   | S |
| P10.23 | 2nd stage speed command   | -6000~6000 | rpm              | 200 | S |
| P10.24 | 2nd stage speed command running time                            | 0~65535    | 0.1sec<br>0.1min | 20  | S |
| P10.25 | 2nd stage acceleration and deceleration time constant selection | 1~7        | -                | 1   | S |
| P10.26 | 3rd speed command   | -6000~6000 | rpm              | 300 | S |
| P10.27 | 3rd stage speed command running time                            | 0~65535    | 0.1sec<br>0.1min | 30  | S |
| P10.28 | 3rd stage acceleration and deceleration time constant selection | 1~7        | -                | 1   | S |
| P10.29 | 4th speed command   | -6000~6000 | rpm              | 400 | S |
| P10.30 | Running time of the 4th speed command                           | 0~65535    | 0.1sec<br>0.1min | 40  | S |
| P10.31 | 4th stage acceleration and deceleration time constant selection | 1~7        | -                | 1   | S |
| P10.32 | 5th speed command   | -6000~6000 | rpm              | 500 | S |
| P10.33 | 5th step speed command running time                             | 0~65535    | 0.1sec<br>0.1min | 50  | S |
| P10.34 | 5th stage acceleration and deceleration time constant selection | 1~7        | -                | 1   | S |
| P10.35 | 6th speed command   | -6000~6000 | rpm              | 600 | S |
| P10.36 | 6th speed command running time                                  | 0~65535    | 0.1sec<br>0.1min | 60  | S |
| P10.37 | 6th stage acceleration and deceleration time constant selection | 1~7        | -                | 1   | S |
| P10.38 | 7th speed command   | -6000~6000 | rpm              | 700 | S |
| P10.39 | 7th stage speed command running time                            | 0~65535    | 0.1sec<br>0.1min | 70  | S |
| P10.40 | 7th stage acceleration and deceleration time constant selection | 1~7        | -                | 1   | S |
| P10.41 | 8th speed command   | -6000~6000 | rpm              | 800 | S |

|        |  |            |                  |      |   |
|--------|--|------------|------------------|------|---|
| P10.42 | 8th speed command running time                                       | 0~65535    | 0.1sec<br>0.1min | 80   | S |
| P10.43 | 8th stage acceleration and deceleration time constant selection      | 1~7        | -                | 1    | S |
| P10.44 | 9th speed command  | -6000~6000 | rpm              | 900  | S |
| P10.45 | 9th stage speed command running time                                 | 0~65535    | 0.1sec<br>0.1min | 90   | S |
| P10.46 | 9th stage acceleration and deceleration time constant selection      | 1~7        | -                | 1    | S |
| P10.47 | 10th speed command   | -6000~6000 | rpm              | 1000 | S |
| P10.48 | 10th speed command running time                                      | 0~65535    | 0.1sec<br>0.1min | 100  | S |
| P10.49 | 10th stage acceleration and deceleration time constant selection     | 1~7        | -                | 1    | S |
| P10.50 | 11th speed command   | -6000~6000 | rpm              | 1100 | S |
| P10.51 | 11th speed command running time                                      | 0~65535    | 0.1sec<br>0.1min | 110  | S |
| P10.52 | 11th stage acceleration and deceleration time constant selection     | 1~7        | -                | 1    | S |
| P10.53 | 12th speed command   | -6000~6000 | rpm              | 1200 | S |
| P10.54 | The 12th speed command running time                                  | 0~65535    | 0.1sec<br>0.1min | 120  | S |
| P10.55 | 12th stage acceleration and deceleration time constant selection     | 1~7        | -                | 1    | S |
| P10.56 | 13th speed command   | -6000~6000 | rpm              | 1300 | S |
| P10.57 | 13th step speed command running time                                 | 0~65535    | 0.1sec<br>0.1min | 130  | S |
| P10.58 | 13th stage acceleration and deceleration time constant selection     | 1~7        | -                | 1    | S |
| P10.59 | 14th speed command   | -6000~6000 | rpm              | 1400 | S |
| P10.60 | 14th step speed command running time                                 | 0~65535    | 0.1sec<br>0.1min | 140  | S |
| P10.61 | The 14th stage acceleration and deceleration time constant selection | 1~7        | -                | 1    | S |
| P10.62 | 15th speed command   | -6000~6000 | rpm              | 1500 | S |
| P10.63 | 15th segment speed command running time                              | 0~65535    | 0.1sec<br>0.1min | 150  | S |
| P10.64 | 15th stage acceleration and deceleration time constant selection     | 1~7        | -                | 1    | S |
| P10.65 | 16th speed command   | -6000~6000 | rpm              | 1600 | S |
| P10.66 | The 16th step speed command running time                             | 0~65535    | 0.1sec<br>0.1min | 160  | S |
| P10.67 | 16th stage acceleration and deceleration time constant selection     | 1~7        | -                | 1    | S |

## Group P11 Auxiliary display

| Parameter number | Name                  | Predetermined area | Unit | Factory setting | Related patterns |
|------------------|-----------------------|--------------------|------|-----------------|------------------|
| P11.00           | 0x603F (error code)   | -                  | -    | -               | Show             |
| P11.01           | 0x6040 (control word) | -                  | -    | -               | Show             |

|                  |  |   |                             |   |      |
|------------------|--|---|-----------------------------|---|------|
| P11.02           | 0x6041 (status word)                                     | - | -                           | - | Show |
| P11.03           | 0x605A (selection of quick stop mode)                    | - | -                           | - | Show |
| P11.04           | 0x605B (shutdown mode selection)                         | - | -                           | - | Show |
| P11.05           | 0x605C (Prohibition of operation mode selection)         | - | -                           | - | Show |
| P11.06           | 0x605E (selection of failure shutdown mode)              | - | -                           | - | Show |
| P11.07           | 0x6060 (mode selection)                                  | - | -                           | - | Show |
| P11.08           | 0x6061 (operation mode display)                          | - | -                           | - | Show |
| P11.09<br>P11.10 | 0x6062 (position command)                                | - | Instruction unit            | - | Show |
| P11.11<br>P11.12 | 0x6063 (position feedback)                               | - | Encoder unit                | - | Show |
| P11.13<br>P11.14 | 0x6064 (position feedback)                               | - | Instruction unit            | - | Show |
| P11.15<br>P11.16 | 0x6065 (position deviation too large threshold)          | - | Instruction unit            | - | Show |
| P11.17           | 0x6066 (Position deviation time window)                  | - | ms                          | - | Show |
| P11.18<br>P11.19 | 0x6067 (position reached threshold)                      | - | Instruction unit            | - | Show |
| P11.20           | 0x6068 (position arrival time window)                    | - | ms                          | - | Show |
| P11.21<br>P11.22 | 0x606C (speed feedback)                                  | - | Command unit/s              | - | Show |
| P11.23           | 0x606D (speed reaches the threshold)                     | - | rpm                         | - | Show |
| P11.24           | 0x606E (speed arrival time window)                       | - | ms                          | - | Show |
| P11.25           | 0x6071 (target torque)                                   | - | 0.1%                        | - | Show |
| P11.26           | 0x6072 (maximum torque)                                  | - | 01%                         | - | Show |
| P11.27           | 0x6073 (maximum current)                                 | - | 0.1%                        | - | Show |
| P11.28           | 0x6074 (internal target torque)                          | - | 0.1%                        | - | Show |
| P11.29           | 0x6077 (Torque feedback)                                 | - | 0.1%                        | - | Show |
| P11.30<br>P11.31 | 0x607A (target position)                                 | - | Instruction unit            | - | Show |
| P11.32<br>P11.33 | 0x607C (origin offset)                                   | - | Instruction unit            | - | Show |
| P11.34<br>P11.35 | 0x607D_1 (minimum software absolute position limit)      | - | Instruction unit            | - | Show |
| P11.36<br>P11.37 | 0x607D_2 (Maximum software absolute position limit)      | - | Instruction unit            | - | Show |
| P11.38           | 0x607E (command polarity)                                | - | -                           | - | Show |
| P11.39<br>P11.40 | 0x607F (maximum contour speed)                           | - | Command unit/s              | - | Show |
| P11.41<br>P11.42 | 0x6081 (contour speed)                                   | - | Command unit/s              | - | Show |
| P11.43<br>P11.44 | 0x6083 (contour acceleration)                            | - | Command unit/s <sup>2</sup> | - | Show |
| P11.45<br>P11.46 | 0x6084 (contour deceleration)                            | - | Command unit/s <sup>2</sup> | - | Show |
| P11.47<br>P11.48 | 0x6085 (rapid stop deceleration)                         | - | Command unit/s <sup>2</sup> | - | Show |
| P11.49<br>P11.50 | 0x6087 (torque ramp)                                     | - | 0.1%/s                      | - | Show |
| P11.51<br>P11.52 | 0x6091_1 (Gear ratio numerator/motor resolution)         | - | -                           | - | Show |
| P11.53<br>P11.54 | 0x6091_2 (Gear ratio denominator/shaft resolution)       | - | -                           | - | Show |
| P11.55           | 0x6098 (return to zero mode)                             | - | -                           | - | Show |
| P11.56<br>P11.57 | 0x6099_1 (search for signal speed of deceleration point) | - | Command unit/s              | - | Show |
| P11.58<br>P11.59 | 0x6099_2 (Search origin signal speed)                    | - | Command unit/s              | - | Show |

|                  |   |   |                             |   |      |
|------------------|---|---|-----------------------------|---|------|
| P11.60<br>P11.61 | 0x609A (zero acceleration)                          | - | Command unit/s <sup>2</sup> | - | Show |
| P11.62<br>P11.63 | 0x60B0 (position offset)                            | - | Instruction unit            | - | Show |
| P11.64<br>P11.65 | 0x60B1 (speed offset)                               | - | Command unit/s              | - | Show |
| P11.66           | 0x60B2 (torque bias)                                | - | 0.1%                        | - | Show |
| P11.67           | 0x60B8 (probe function)                             | - | -                           | - | Show |
| P11.68           | 0x60B9 (probe status)                               | - | -                           | - | Show |
| P11.69<br>P11.70 | 0x60BA (probe 1 rising edge position feedback)      | - | Instruction unit            | - | Show |
| P11.71<br>P11.72 | 0x60BB (Probe 1 falling edge position feedback)     | - | Instruction unit            | - | Show |
| P11.73<br>P11.74 | 0x60BC (probe 2 rising edge position feedback)      | - | Instruction unit            | - | Show |
| P11.75<br>P11.76 | 0x60BD (Probe 2 falling edge position feedback)     | - | Instruction unit            | - | Show |
| P11.77           | 0x60D5 (probe 1 rising edge counter)                | - | -                           | - | Show |
| P11.78           | 0x60D6 (Probe 1 falling edge counter)               | - | -                           | - | Show |
| P11.79           | 0x60D7 (probe 2 rising edge counter)                | - | -                           | - | Show |
| P11.80           | 0x60D8 (Probe 2 falling edge counter)               | - | -                           | - | Show |
| P11.81           | 0x60E0 (maximum forward torque limit)               | - | 0.1%                        | - | Show |
| P11.82           | 0x60E1 (Maximum torque limit in negative direction) | - | 0.1%                        | - | Show |
| P11.83<br>P11.84 | 0x60F4 (position deviation)                         | - | Instruction unit            | - | Show |
| P11.85<br>P11.86 | 0x60FC (position command)                           | - | Instruction unit            | - | Show |
| P11.87<br>P11.88 | 0x60FD (digital input)                              | - | -                           | - | Show |
| P11.89<br>P11.90 | 0x60FE_1 (physical output enable)                   | - | -                           | - | Show |
| P11.91<br>P11.92 | 0x60FE_2 (physical output status)                   | - | -                           | - | Show |
| P11.93<br>P11.94 | 0x60FF (target speed)                               | - | Command unit/s              | - | Show |
| P11.95<br>P11.96 | 0x6052 (supported servo operation mode)             | - | -                           | - | Show |

## Group P12 Auxiliary functions

| Parameter number | Name  | Predetermined area | Unit | Factory setting | Related patterns |
|------------------|---|--------------------|------|-----------------|------------------|
| P12.00           | Save parameters to the EEPROM of the Driver           | 0~1                | -    | 0               | -                |
| P12.01           | Read parameters from the EEPROM of the Driver         | 0~1                | -    | 0               | -                |
| P12.02           | Restore factory default parameter values              | 0~1                | -    | 0               | -                |
| P12.03           | Reset Driver failure                                  | 0~1                | -    | 0               | -                |
| P12.04           | Reserve   | -                  | -    | -               | -                |
| P12.05           | Reset the encoder multi-turn value                    | 0~1                | -    | 0               | -                |
| P12.06           | Reset the encoder multi-turn value and fault          | 0~1                | -    | 0               | -                |
| P12.07           | Reset Driver  | 0~1                | -    | 0               | -                |
| P12.08           | Reset fault record                                    | 0~1                | -    | 0               | -                |
| P12.09           | Communication control operation position command type | 0~1                | -    | 0               | -                |

|        |  |         |   |     |   |
|--------|--|---------|---|-----|---|
| P12.10 | Communication control operation start/stop command                   | 0~6     | - | 6   | - |
| P12.11 | Reserve  | -       | - | -   | - |
| P12.12 | Communication control demonstration running delay time               | 0~65535 | - | 100 | - |
| P12.13 | Communication control demonstration operation start/stop instruction | 0~2     | - | 0   | - |
| P12.14 | Clear position error   | 0~1     | - | 0   | - |
| P12.15 | Reserve  | -       | - | 0   | - |
| P12.16 | Data sampling channel 1  | 0~65535 | - | 0   | - |
| P12.17 | Data sampling channel 2  | 0~65535 | - | 0   | - |
| P12.18 | Data sampling interval   | 0~65535 | - | 0   | - |
| P12.19 | Data sampling start flag   | 0~1     | - | 0   | - |
| P12.20 | Save motor related parameters to encoder EEPROM                      | 0~2     | - | 0   | - |
| P12.21 | Test energy consumption braking action and feedback                  | 0~2     | - | 0   | - |

### Group P13 Monitoring parameters

| Parameter number | Name                                      | Predetermined area | Unit             | Factory setting | Related patterns |
|------------------|---|--------------------|------------------|-----------------|------------------|
| P13.00           | Operating status                          | -                  | -                | -               | Show             |
| P13.01           | Motor speed                               | -                  | rpm              | -               | Show             |
| P13.02           | Speed command                             | -                  | rpm              | -               | Show             |
| P13.03           | Motor torque                              | -                  | %                | -               | Show             |
| P13.04           | Torque command                            | -                  | %                | -               | Show             |
| P13.05           | Operating current                         | -                  | %                | -               | Show             |
| P13.07<br>P13.08 | Position command counter                  | -                  | Instruction unit | -               | Show             |
| P13.09<br>P13.10 | Position command counter*                 | -                  | Encoder unit     | -               | Show             |
| P13.11<br>P13.12 | Position feedback counter                 | -                  | Coding unit      | -               | Show             |
| P13.13<br>P13.14 | Position deviation counter                | -                  | Instruction unit | -               | Show             |
| P13.15<br>P13.16 | Position deviation counter                | -                  | Coding unit      | -               | Show             |
| P13.17           | Position command speed                    | -                  | rpm              | -               | Show             |
| P13.18           | Position command frequency                | -                  | KHz              | -               | Show             |
| P13.19           | Input signal monitoring                   | -                  | -                | -               | Show             |
| P13.20           | Output signal monitoring                  | -                  | -                | -               | Show             |
| P13.21<br>P13.22 | The current mechanical angle of the motor | -                  | Encoder unit     | -               | Show             |
| P13.23           | The current electrical angle of the motor | -                  | Spend            | -               | Show             |
| P13.24           | The current voltage value of the Driver   | -                  | 0.1V             | -               | Show             |
| P13.25<br>P13.26 | Encoder status register                   | -                  | -                | -               | Show             |
| P13.27<br>P13.28 | External pulse counter                    | -                  | Instruction unit | -               | Show             |
| P13.29           | Divided output pulse count                | -                  | Instruction unit | -               | Show             |

|                  |                                 |   |                  |   |      |
|------------------|---------------------------------|---|------------------|---|------|
| P13.30<br>P13.31 | Current position of the motor   | - | Instruction unit | - | Show |
| P13.32<br>P13.33 | target location                 | - | Instruction unit | - | Show |
| P13.36           | Error code                      | - | -                | - | Show |
| P13.40<br>P13.41 | Motor encoder single-turn value | - | Encoder unit     | - | Show |
| P13.42<br>P13.43 | Motor encoder multi-turn value  | - | lock up          | - | Show |