



RS Series Servo User Manual

Preface

Thank you for purchasing the RS series V3.0 servo drive!

RS series V3.0 servo drive is the third generation of general-purpose AC servo drive developed by Rteelligent. The power range of this series products is 0.05~3KW, and it supports RS485-based MODBUS communication protocol. It can be used for network operation of multiple drives. The drive also contains an internal PLC mode to facilitate customer customization

The RS series servo system is equipped with a standard 17~23-bit single-turn/multi-turn absolute encoder motor, and the frame below 80 adopts a full series of ultra-short high-density servo motors. It can achieve ultra-small installation dimension and high speed precise positioning.

The RS series servo system has the characteristics of fast positioning and good adaptability. The drive has three basic control modes (position control, speed control, torque control). In addition, more flexible application functions can be realized by using the drive "internal PLC programming" or "485 communication".

This manual is a comprehensive user manual for the RS series V3.0 servo drive. Please read this manual carefully to confirm the relevant information before the formal power-on connection. If you have any doubts about the functions and performance of the product, please consult our technical support.

As we are committed to the continuous improvement of servo drives, the information provided by the company is subject to change without prior notice.

Revision History

Date	Version	Description
2017.07	V1.0	Version 1 release
2018.05	V2.0	Version 2 release
2019.09	V2.1	Version 2 product updates
2020.10	V3.0	Version 3 product updates
2021.12	V3.1	<ol style="list-style-type: none">1、 Modify the parameter address error in the description of the control mode2、 New parameter function description3、 Modify other errors
2022.10	V3.2	<ol style="list-style-type: none">1、 Modify the technical specifications of the servo drive and motor2、 Modify the drive dimension error3、 Modify the wrong description of the accessory model4、 Modify the description of the braking resistor5、 Rearrange the chapters6、 Modify other errors

Contents

Preface	1
Revision History	2
Contents	3
1. Safety Instructions	6
1.1. Safety Precautions	6
1.2. Unpacking Inspection	7
1.3. Packing list	7
2. Product Information	8
2.1. Drive Introduction	8
2.1.1. Drive Naming	8
2.1.2. Drive Specifications	8
2.2. Motor Introduction	9
2.2.1. Motor Naming	9
2.2.2. Motor Specifications	10
2.2.3. Encoder Type	10
2.3. Braking Resistor Introduction	11
2.4. Accessories	12
2.4.1. Motor & Encoder Cables	12
2.4.2. Mini-USB Debugging Cable	13
2.4.3. RS485 Communication Cable	13
3. Installation	14
3.1. Servo Drive Installation	14
3.1.1. Drive Environment	14
3.1.2. Dimension	14
3.1.3. Installation Precaution	15
3.2. Servo Motor Installation	16
3.2.1. Motor Environment	16
3.2.2. Dimension	16
3.2.3. Installation Precaution	19
4. Wiring	20
4.1. Drive Interface & Connection	20
4.2. Power Port	20
4.3. Encoder Signal-CN2	21
4.4. Control Signal-CN1	22
4.4.1. Pin Definition	22
4.4.2. Position Command Input Signal	24

4.4.3. Digital Input Signal	25
4.4.4. Digital Output Signal	27
4.4.5. Analog Input Signal	29
4.4.6. Encoder Output Signal	29
4.4.7. Motor Brake Wiring	30
4.5. Anti-interference Countermeasures for Electrical Wiring	31
5. Control Panel	32
5.1. Panel Overview	32
5.1.1. Panel Composition Introduction	32
5.1.2. Panel Display Content	32
5.1.3. Panel Operation	33
5.1.4. Data Display	33
5.1.5. Fault Display	35
5.1.6. Monitor Display	35
5.2. Parameter Setting	37
5.3. Auxiliary Function	37
5.3.1. Parameter Management	37
5.3.2. Fault Reset	38
5.3.3. Absolute Value Operation	39
5.3.4. Jog Test Machine	39
5.3.5. Open Loop Test	39
5.3.6. Encoder Calibration	40
5.3.7. Jog Operation	40
5.3.8. Fixed-length/Continuous Operation	40
6. Control Mode	41
6.1. Position Control Mode	41
6.1.1. Position Command Input Setting	41
6.1.2. Electronic Gear Ratio	54
6.1.3. Position Command Filtering	56
6.1.4. Signal Positioning Complete Signal	57
6.1.5. Homing Function	58
6.1.6. Interrupt Fixed-length Function	63
6.2. Speed Control Mode	64
6.2.1. Speed Command Input Setting	64
6.2.2. Speed Related Output Signal	78
6.3. Torque Control Mode	80
6.3.1. Torque Command Input Setting	80
6.3.2. Speed Limit in Torque Mode	86

6.3.3. Torque Arrival Output	86
6.4. Hybrid Control Mode	87
7. Parameter Description	89
7.1. Group P00: Servo Drive/Motor Parameters	90
7.2. Group P01: Basic Control Parameters	94
7.3. Group P02: Terminal Input/Output Parameters	98
7.4. Group P03: Position Control Parameters	105
7.5. Group P04: Speed Control Parameters	112
7.6. Group P05: Torque Control Parameters	117
7.7. Group P06: Gain Parameters	121
7.8. Group P08: Communication Parameters	125
7.9. Group P09: Multi-segment Position Parameters	127
7.10. Group P10: Multi-segment Speed Parameters	135
7.11. Group P11: Auxiliary Display	143
7.12. Group P12: Auxiliary Functions	147
7.13. Group P13: Monitoring Parameters	150
8. Communication	155
8.1. Communication Parameters Setting	155
8.2. MODBUS Communication Protocol	156
8.2.1. Read Register Data: 0x03	157
8.2.2. Write a Single Register: 0x06	158
8.2.3. Write Multiple Registers: 0x10	159
8.2.4. Error Response Frame Format	160
8.2.5. CRC Check	161
9. Troubleshooting	162
9.1. Error Code	162

1. Safety Instructions

1.1. Safety Precautions

- ◆ Please disconnect the power supply for more than 5 minutes before removing or disassembling the drive, otherwise it may cause electric shock due to residual voltage.
- ◆ Please never touch the inside of the servo drive, otherwise it may cause electric shock.
- ◆ Please insulate the connection part of the power supply terminal, otherwise it may cause electric shock.
- ◆ The ground terminal of the servo drive must be grounded, otherwise it may cause electric shock.
- ◆ Please do not damage or pull on the cable, subject the cable to excessive force, put it under heavy objects or clamp it. Doing so may result in electric shock, which may cause the product to stop or burn out.
- ◆ Unless designated personnel, please do not set up, disassemble or repair, otherwise it may cause electric shock or injury.
- ◆ Please do not remove the cover, cables, connectors and optional accessories while the power is on, otherwise it may cause electric shock and damage the drive.
- ◆ Please follow the steps required by this manual for trial operation.
- ◆ If an operation error occurs while the servo motor is connected to the machine, it will not only cause damage to the machine, but also sometimes cause personal accidents.
- ◆ Please do not change the maximum speed value, except for special purposes. Inadvertent change may damage the machine or cause injury.
- ◆ When the power is turned on and for a period of time after the power is cut off, the heat sink of the servo drive, the external braking resistor, and the servo motor may become hot. Please do not touch it, otherwise it may cause burns. To prevent accidental contact with hands or parts (cables, etc.), please take safety precautions such as installing an enclosure.
- ◆ Please do not touch the rotating part of the servo motor while it is running, as this may result in injury.
- ◆ If the servo motor is installed on the supporting machine and starts to run, make sure that the servo motor can be stopped at any time, otherwise you may get injured.
- ◆ Please install a stop device on the machine side to ensure safety.
- ◆ The brake of the servo motor with brake is not a stopping device to ensure safety. If a stop device is not provided, it may cause injury.
- ◆ If power is restored after a momentary power failure occurs during operation, the machine may restart suddenly, so please do not approach the machine.
- ◆ Please take measures to ensure that personal safety will not be endangered when restarting, otherwise it may cause injury.
- ◆ Please do not modify the product in any way, otherwise it may cause injury or mechanical damage.

- ◆ Please install the servo drive, servo motor, and external braking resistor on non-combustible materials, otherwise it may cause a fire.
- ◆ Between the power supply and the main circuit power supply of the servo drive (single-phase L1, L2, three-phase L1, L2, L3), be sure to connect an electromagnetic contactor and a non-fuse circuit breaker. Otherwise, when the servo drive fails, the large current cannot be cut off, which may cause a fire.
- ◆ In the servo drive and servo motor, please do not mix oil, grease and other flammable foreign objects and screws, metal pieces and other conductive foreign objects, otherwise it may cause fire and other accidents.

1.2. Unpacking Inspection

Items	Description
Check whether the delivered products comply with you ordered.	The packaging box contains the products you ordered. Please confirm it by the nameplate model of the servo motor and servo drive.
Check whether the products are intact.	Please check the product surface to see if the product is damaged during transportation. If any omission or damage is found, please contact our company or your supplier as soon as possible.
Check whether the motor is rotating smoothly	It is normal to be able to turn gently by hand. Except for servo motors with brakes.

1.3. Packing list

No.	Products
1	RS servo drive * 1 (including one DB44 terminal kit + one main circuit terminal)
2	Servo motor * 1
3	Motor supporting power extension cable*1
4	Motor supporting encoder extension cable*1
5	Brake extension cable for brake motor * 1 (special for motor with brake)
6	Drive debugging software communication cable * 1 (optional)

2. Product Information

2.1. Drive Introduction

2.1.1. Drive Naming

RS 400 C

Symbol	Description
RS	Rtelligent AC servo drive
400	Drive output power: 100: 100W 200: 200W 400: 400W 750: 750W 1000: 1000W 1500: 1500W 3000: 3000W
C	Function code: None: Pulse + RS485 communication, standard E: EtherCAT communication C: Pulse

◆ Note: Model naming rules are only used to resolve model meanings.

2.1.2. Drive Specifications

1. Basic specifications

Model	RS100	RS200	RS400	RS750	RS1000	RS1500	RS3000
Rated power	100W	200W	400W	750W	1KW	1.5KW	3KW
Continuous current	3.0A	3.0A	3.0A	5.0A	7.0A	9.0A	12.0A
Maximum current	9.0A	9.0A	9.0A	15.0A	21.0A	27.0A	36.0A
Power supply	Single-phase 220VAC			Single-phase 220VAC			Single-phase/Three-phase 220VAC
Size code	Type A			Type B			Type C
Size	175*156*40			175*156*51			196*176*72

2. Electrical specifications

Item	Description
Control mode	IPM PWM control, SVPWM drive mode
Encoder type	Match 17~23Bit optical or magnetic encoder, support absolute encoder control
Pulse input specifications	5V differential pulse/2MHz; 24V single-ended pulse/200KHz
Analog input specifications	2 channels, -10V ~ +10V analog input channel Note: Only RS standard servo has analog interface
Universal input	9 channels, support 24V common anode or common cathode
Universal output	4 single-ended + 2 differential outputs, Single-ended: 50mA Differential: 200mA
Encoder output	ABZ 3 differential outputs (5V) + ABZ 3 single-ended outputs (5-24V) Note: Only RS standard servo has encoder frequency division output interface

2.2. Motor Introduction

2.2.1. Motor Naming

RSNA M 06 J 13 30 A - Z

- | | | |
|--|--|--|
| <p>1 Serial name
A: Five pairs of poles, ultra-thin, silver</p> <p>2 Motor inertia code
S: Small inertia M: Medium inertia
H: Large inertia</p> <p>3 Motor flange size
06:60mm 13:130mm</p> | <p>4 Encoder code
J : 17bit magnetic unicyclic absolute encoder
H : 23bit optical unicyclic absolute encoder
G : 17bit magnetic multiturn absolute encoder
L : 23bit optical multiturn absolute encoder</p> <p>5 Motor rated torque
13:1.3 Nm 150: 15 Nm</p> | <p>6 Motor rated speed
30: 3000 rpm 15: 1500 rpm</p> <p>7 Is there an oil seal
A: With oil seal inside
None: No oil seal inside</p> <p>8 Brake code
Z: With brake</p> |
|--|--|--|

◆ Note: Model naming rules are only used for model meaning analysis. For specific optional models, please refer to the details page.

2.2.2. Motor Specifications

1. Basic specifications

Frame (mm)	Model	Power	Motor length (mm)	Motor length with brake (mm)
40	RSNA-M04J0130A	50W	61.5	93.5
	RSNA-M04J0330A	100W	81.5	110
60	RSNA-M06J0630A	200W	80	109
	RSNA-M06J1330A	400W	98	127
80	RSNA-M08J2430A	750W	107	144
	RSNA-M08J3230A	1000W	127	163
110	RS□-M11J4030A	1.2KW	189	294
	RS□-M11J5030A	1.5KW	204	264
	RS□-M11J6030A	1.8KW	219	294
130	RS□-M13J4025A	1.0KW	166	223
	RS□-M13J6025A	1.5KW	179	236
	RS□-M13J7725A	2.0KW	192	249
	RS□-M13J10025A	2.5KW	209	290
	RS□-M13J15015A	2.3KW	241	322
	RS□-M13J15025A	3.8KW	231	303

- ◆ Note: The encoder comes standard with 17-bit magnetic encoding, 23-bit optical encoding is optional, and multi-turn absolute value specifications are optional.

2. Electrical specifications

Item	Description
Rated voltage	220V
Encoder type	17bit magnetic encoder / 23bit optical encoder optional

2.2.3. Encoder Type

1. Encoder specifications

Encoder code	Description
J	17-bit single-turn magnetic absolute encoder
H	23-bit single-turn optical absolute encoder
G	17-bit multi-turn magnetic absolute encoder
L	23-bit multi-turn optical absolute encoder

2. Encoder performance instructions

- ◆ The encoder is the position counting device of the servo motor, and the feedback of the motor position and speed information provides the most important basis for the control of the drive. It is obvious that a high-resolution encoder can "cut" the movement of the motor in one revolution into smaller units, so a high-resolution encoder can provide higher precision information.
- ◆ The absolute encoder can feedback the absolute number of turns of the encoder, and can be connected to an external battery to keep the position information of the motor even after the drive is powered off. It is generally used in some occasions with high precision and precise positioning.
- ◆ Restricted by the encoder manufacturing process and servo drive acquisition capabilities, our company provides up to 23-bit photoelectric encoders with the highest resolution of 8388608. In actual use, because of the working conditions, we can choose a slightly lower resolution encoder to reduce the cost of the motor while ensuring a certain accuracy. Therefore, please choose the encoder specification of the servo motor reasonably according to your actual situation.

2.3. Braking Resistor Introduction

When the output torque of the motor and the rotation speed are in the opposite direction, it represents the energy transferred from the load end to the drive. This energy is fed back to the capacitor in the DC bus so that its voltage value rises. When it rises to a certain value, the capacitor cannot fully absorb the feedback energy, and a braking resistor is needed to dissipate it.

The braking resistor is connected to the P+ and Br ports. The drive has a braking resistor with a certain power. When the built-in resistor of the drive is not enough to absorb the braking energy consumption, the user can also connect an external braking resistor with a larger power. In this case, it is only necessary to replace the braking resistor built in the drive with a high-power braking resistor.

1. Regenerative resistor specifications

Drive model	RS100	RS400	RS750	RS1000	RS1500	RS3000
Rated power	100W	400W	750W	1KW	1.5KW	3KW
Continuous current	3.0A	3.0A	5.0A	7.0A	9.0A	12.0A
Maximum current	9.0A	9.0A	15.0A	21.0A	27.0A	36.0A
Built-in braking resistor resistance and power	-	-	50 Ω		50 Ω	
	-	-	75W		100W	
Allowable braking power	-	-	38W		50W	
Minimum resistance of external braking resistor	-	-	30 Ω		20 Ω	

2. Configuration reference of braking resistor

As mentioned in the above table, the braking energy of the drive returns to the DC bus first. When the feedback superimposed voltage exceeds the reference value set by the drive (that is, the maximum absorption capacity of the DC bus capacitor), the braking energy enters the braking resistor.

When the built-in braking resistor of the drive cannot meet the discharge requirements, it is necessary to replace the braking resistor with a larger specification. The power of the braking resistor needs to be greater than the power of the built-in braking resistor of the drive. The resistance of the braking resistor needs to meet certain requirements, and the minimum resistance should not be lower than the lower limit listed in the above table.

Generally speaking, the greater the load inertia and the shorter the acceleration and deceleration time, the greater the braking energy and the greater the braking resistor power required.

2.4. Accessories

2.4.1. Motor & Encoder Cables

1. Wiring matching table

(1) AMP plug type motor (Frame 40/60/80mm)

Cable type	Cable length		
	3 meters	5 meters	8 meters
Motor cable	SMS4-030A	SMS4-050A	SMS4-080A
Single-turn absolute encoder cable	SES4-030	SES4-050	SES4-080
Multi-turn absolute encoder cable	SES6-030	SES6-050	SES6-080
Brake cable	SMBZ2-030	SMBZ2-050	SMBZ2-080

(2) Aviation plug type motor (Frame 110/130mm)

Cable type	Cable length		
	3 meters	5 meters	8 meters
Motor cable	SMH4-030	SMH4-050	SMH4-080
Single-turn absolute encoder cable	SEH4-030	SEH4-050	SEH4-080
Multi-turn absolute encoder cable	SEH6-030	SEH6-050	SEH6-080
Brake cable	HMBZ2-030	HMBZ2-050	HMBZ2-080

- ◆ Note: The standard length of the extension cable is 3 meters, if you need other sizes, please specify when ordering.

2. Motor wiring requirements

- ◆ The motor power cable needs to meet certain current carrying requirements, The motor with frame 40/60/80mm shall use the wire diameter specification of 0.5mm² or above, and the motor with frame 110/130mm shall use the wire diameter specification of 0.75mm² or above.
- ◆ The encoder cable of motor needs to meet the requirements of shielding isolation, standard configuration 0.14mm² wire diameter, twisted pair, shielded cable.
- ◆ For drag chains or similar use environments, please be sure to use flexible cables that meet the requirements to ensure the normal operation of the servo system.
- ◆ The cable installed in the drag chain needs to maintain a certain amount of space, and do not artificially increase the bending angle of the cable.

2.4.2. Mini-USB Debugging Cable

Please use Mini-USB cable with magnetic ring, please contact after-sales service or official website to download the driver.

2.4.3. RS485 Communication Cable

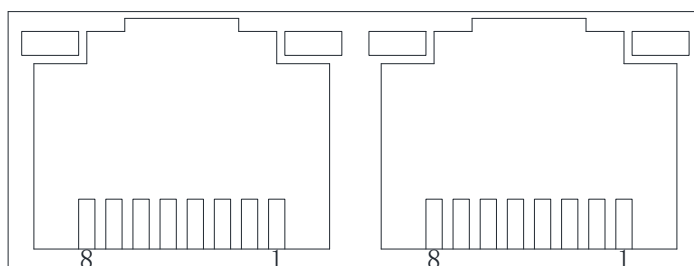

Signal		Pin	Function
Communication signal	RS485+	1	RS485 communication port
	RS485-	2	
	-	3	-
	-	4	-
	-	5	-
	-	6	-
	DGND	7	GND signal
	-	8	-

3. Installation

3.1. Servo Drive Installation

3.1.1. Drive Environment

Item	Requirement
Ambient temperature	0~55° C (The average load rate should not exceed 80% when the ambient temperature is above 45° C)
Storage temperature	-20~85°C
Ambient/storage humidity	Below 90%RH (free from condensation)
Vibration	4.9m/s ²
Impact	19.6m/s ²
Protection class	IP10
Altitude	Less than 1000m

3.1.2. Dimension

1. Size A: Below 400W

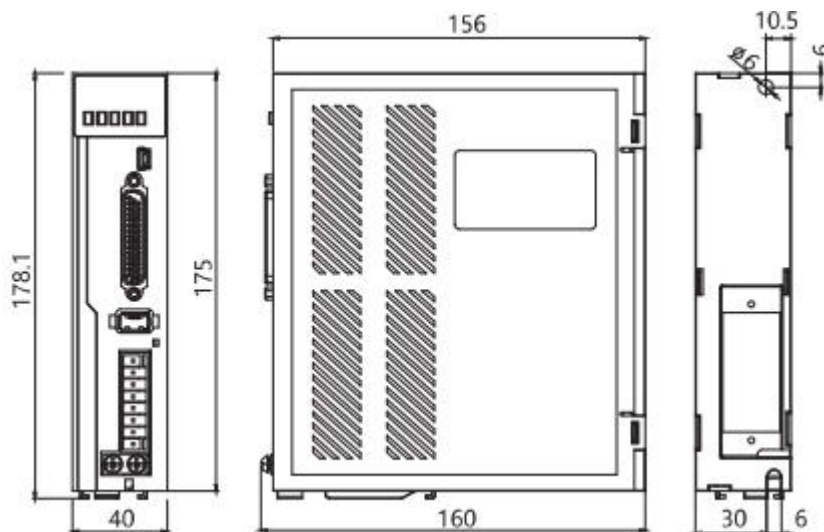

2. Size B: Below 2000W

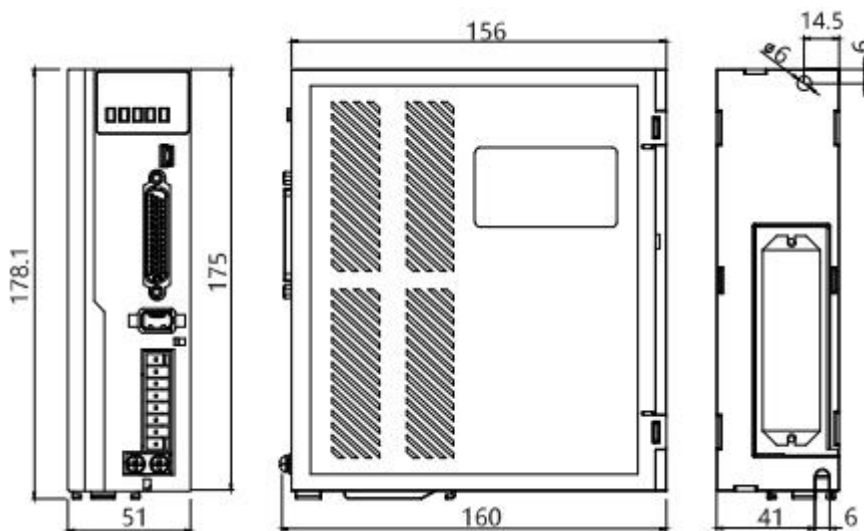

3. Size C: Below 3000W

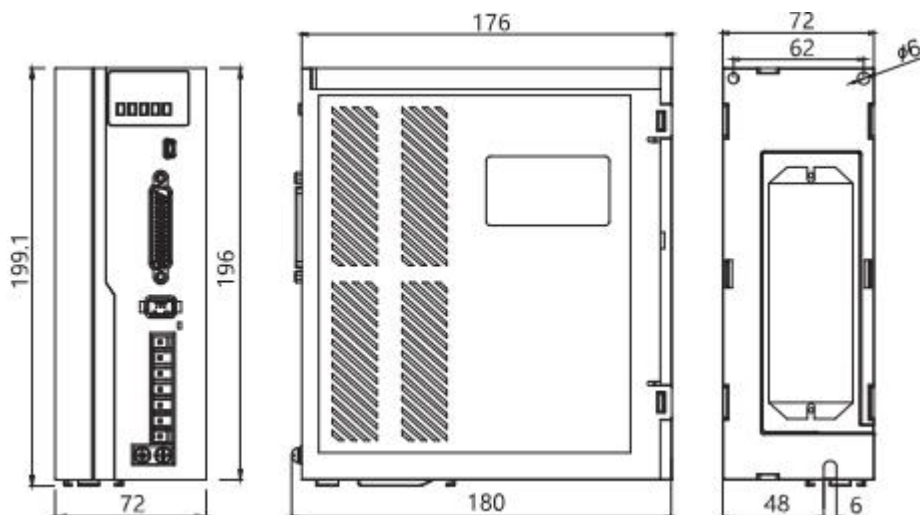

3.1.3. Installation Precaution

- ◆ Please install the drive in an electrical cabinet free from sunlight and rain.
- ◆ Do not place the drive in a corrosive or other harmful environment.
- ◆ Please ensure that the installation direction is perpendicular to the wall, and use natural air convection or a fan to cool the servo drive. Fix the servo drive firmly on the mounting surface through 2~4 mounting holes (the number of mounting holes varies according to the capacity). When installing, please face the front of the drive to the operator and make it perpendicular to the wall. Please pay attention to avoid drilling chips and other foreign matter from falling into the driver during installation, otherwise it may cause drive failure.
- ◆ When multiple drives are installed in the control cabinet, please note that sufficient space must be reserved for the placement position to achieve sufficient heat dissipation.

- ◆ Be sure to connect the ground terminal to the ground, otherwise there may be a risk of electric shock or interference resulting in malfunction.
- ◆ When there is a vibration source (punch) near the drive installation, if it is unavoidable, please use a vibration absorber or install an anti-vibration rubber gasket.
- ◆ When there are noise interference sources such as large magnetic switches and fusion splicers near the drive, it is easy to cause the drive to be interfered by the outside and cause malfunction. At this time, a noise filter needs to be installed, but the noise filter will increase the leakage current, therefore, it is necessary to install an insulating transformer on the input end of the drive.

3.2. Servo Motor Installation

3.2.1. Motor Environment

Item	Requirement
Ambient temperature	0~40°C
Storage temperature	-20~60°C
Ambient/storage humidity	Below 90%RH (free from condensation)
Vibration	49m/s ²
Impact	196m/s ²
Protection class	IP65
Altitude	Below 1000m

3.2.2. Dimension

1. Frame 40mm (AMP plug outlet*)

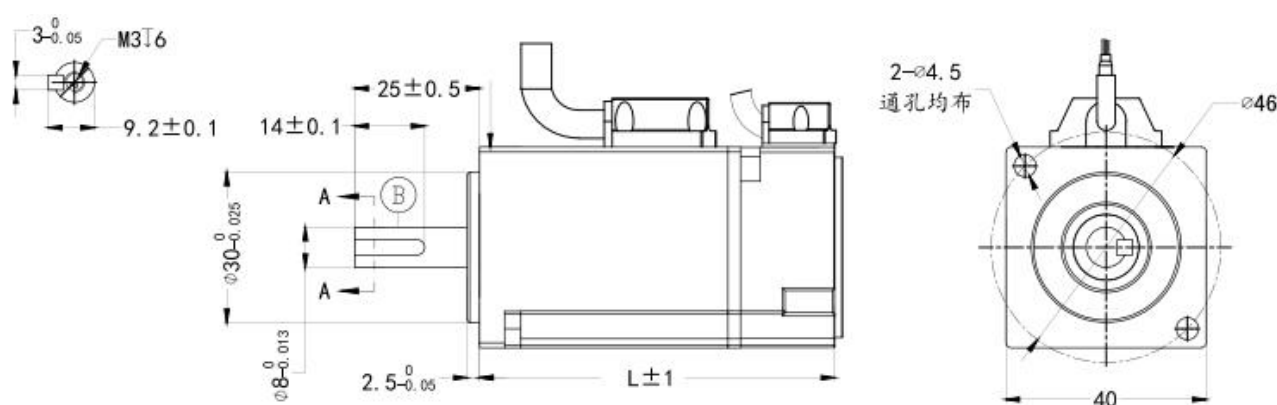

Description	Model	Length (mm)	Weight (Kg)
50W	RSNA-M04J0130A	61.5	0.35
100W	RSNA-M04J0330A	81.5	0.46
50W with brake	RSM-M04L0130A-Z-ST	93.5	0.52
100W with brake	RSNA-M04J0330A-Z	110	0.66

2. Frame 60mm (AMP plug outlet*)

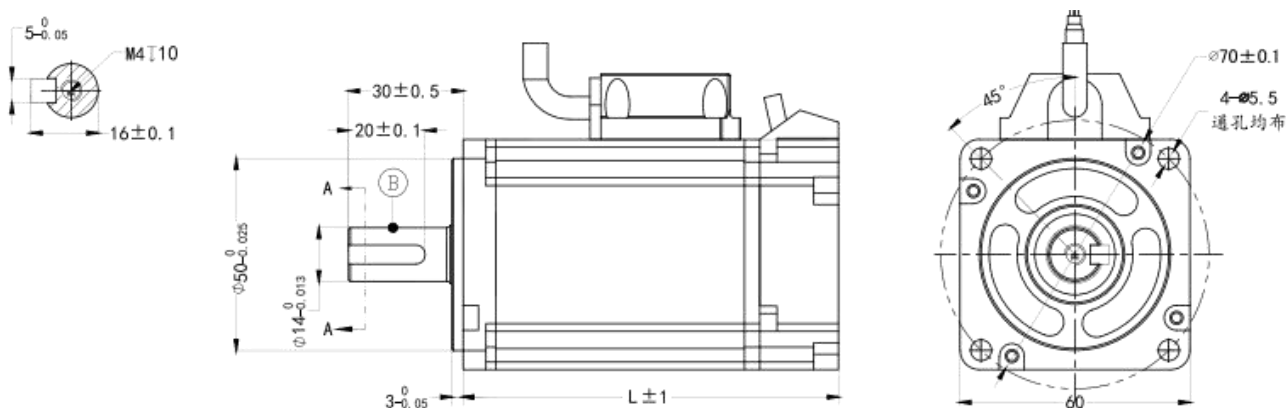

Description	Model	Length (mm)	Weight (Kg)
200W	RSNA-M06J0630A	80	0.84
400W	RSNA-M06J1330A	98	1.19
200W with brake	RSNA-M06J0630A-Z	109	1.21
400W with brake	RSNA-M06J1330A-Z	127	1.56

3. Frame 80mm (AMP plug outlet*)

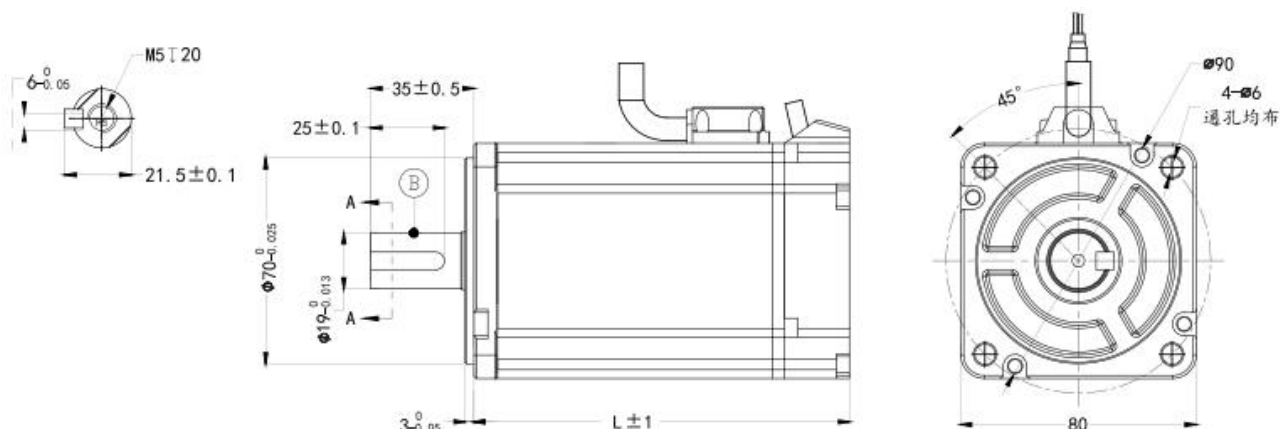

Description	Model	Length (mm)	Weight (Kg)
750W	RSNA-M08J2430A	107	2.27
1000W	RSNA-M08J3230A	127	2.95
750W with brake	RSNA-M08J2330A-Z	144	3.05
1000W with brake	RSNA-M08J3230A-Z	163	3.73

4. Frame 110mm (Aviation plug outlet*)

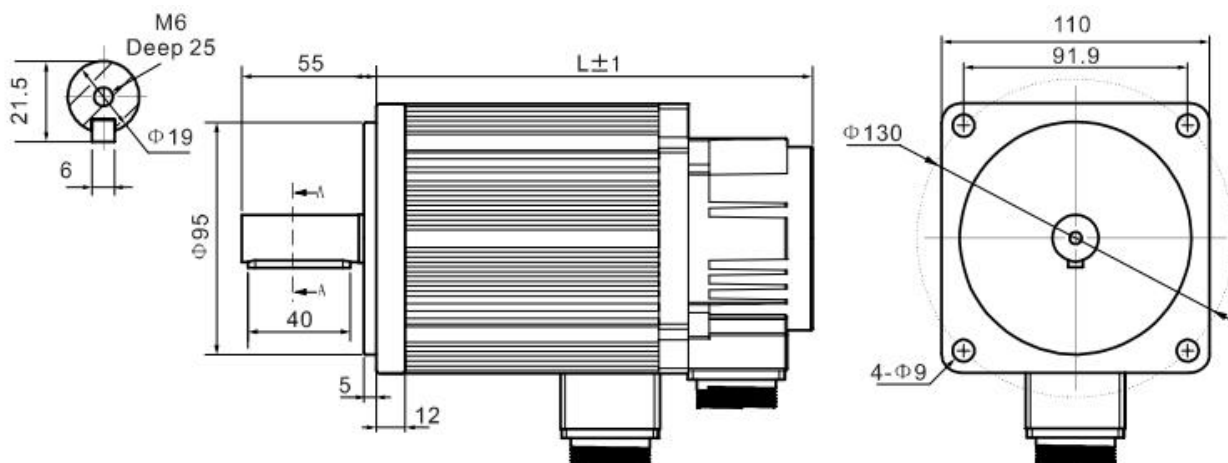

Description	Model	Length (mm)	Weight (Kg)
1.2KW	RS□-M11J4030A	189	6.0
1.5KW	RS□-M11J5030A	204	6.8
1.2KW	RS□-M11J6020A	219	7.9
1.8KW	RS□-M11J6030A	219	7.9
1.2KW with brake	RS□-M11J4030A-Z	294	6.5
1.5KW with brake	RS□-M11J5030A-Z	264	7.3
1.2KW with brake	RS□-M11J6020A-Z	279	8.4
1.8KW with brake	RS□-M11J6030A-Z	294	8.4

5. Frame 130mm (Aviation plug outlet*)

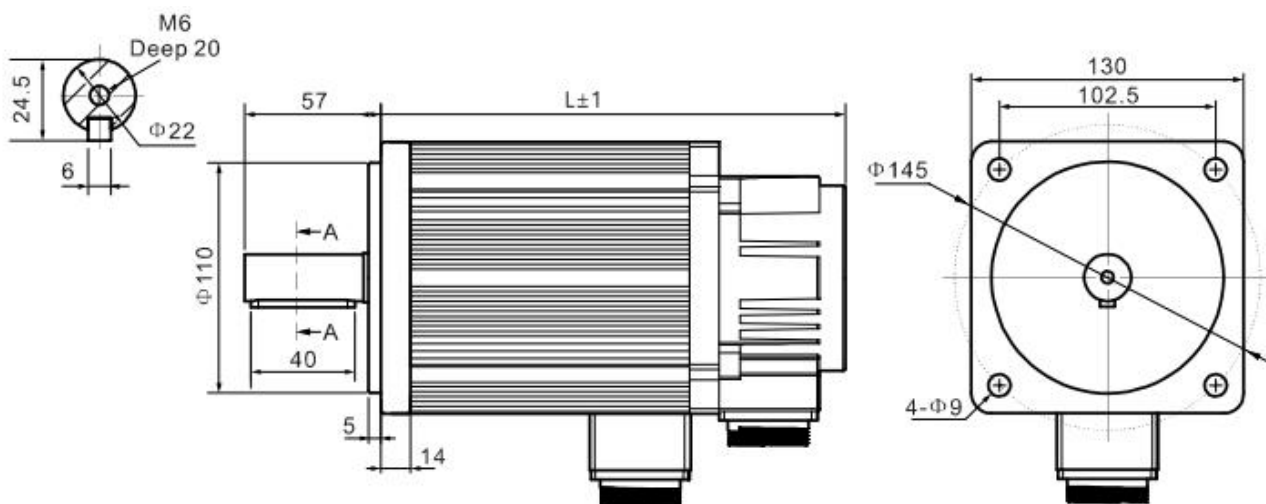

Description	Model	Length (mm)	Weight (Kg)
1.0KW	RS□-M13J4025A	166	6.2
1.5KW	RS□-M13J6025A	179	7.4
2.0KW	RS□-M13J7725A	192	8.3
2.6KW	RS□-M13J10025A	209	9.8
2.3KW	RS□-M13J15015A	241	12.6
3.8KW	RS□-M13J15025A	231	11.7
1.0KW with brake	RS□-M13J4025A-Z	223	7.8
1.5KW with brake	RS□-M13J6025A-Z	236	9.0
2.0KW with brake	RS□-M13J7725A-Z	249	9.9
2.6KW with brake	RS□-M13J10025A-Z	290	11.4
2.3KW with brake	RS□-M13J15015A-Z	332	14.2
3.8KW with brake	RS□-M13J15025A-Z	303	13.3

Remark:

- ◆ The AMP plug outlet specification is "4 holes motor wire + 9 holes encoder wire + 2 holes brake wire".
- ◆ The aviation plug outlet specification is "4 holes motor wire + 7 holes encoder wire + 2 holes brake wire"

3.2.3. Installation Precaution

- ◆ Please ensure that the installation direction is perpendicular to the wall, and use natural air convection or a fan to cool the servo drive. By 2 ~ 4 mounting holes (the number of mounting holes varies according to the capacity), and the servo drive is firmly fixed on the mounting surface. When installing, please face the front of the drive to the operator and make it perpendicular to the wall. Please pay attention to avoid drilling chips and other foreign matter from falling into the drive during installation, otherwise it may cause drive failure.
- ◆ When multiple drivers are installed in the control cabinet, please note that sufficient space must be reserved for the placement position to achieve sufficient heat dissipation.
- ◆ Be sure to connect the ground terminal to the ground, otherwise there may be a risk of electric shock or interference resulting in malfunction.
- ◆ When there is a vibration source (punch) near the drive installation, if it is unavoidable, please use a vibration absorber or install an anti-vibration rubber gasket.
- ◆ When there are noise interference sources such as large magnetic switches and fusion splicers near the drive, it is easy to cause the drive to be interfered by the outside and cause malfunction. At this time, a noise filter needs to be installed, but the noise filter will increase the leakage current, therefore, it is necessary to install an insulating transformer on the input end of the drive.

4. Wiring

4.1. Drive Interface & Connection

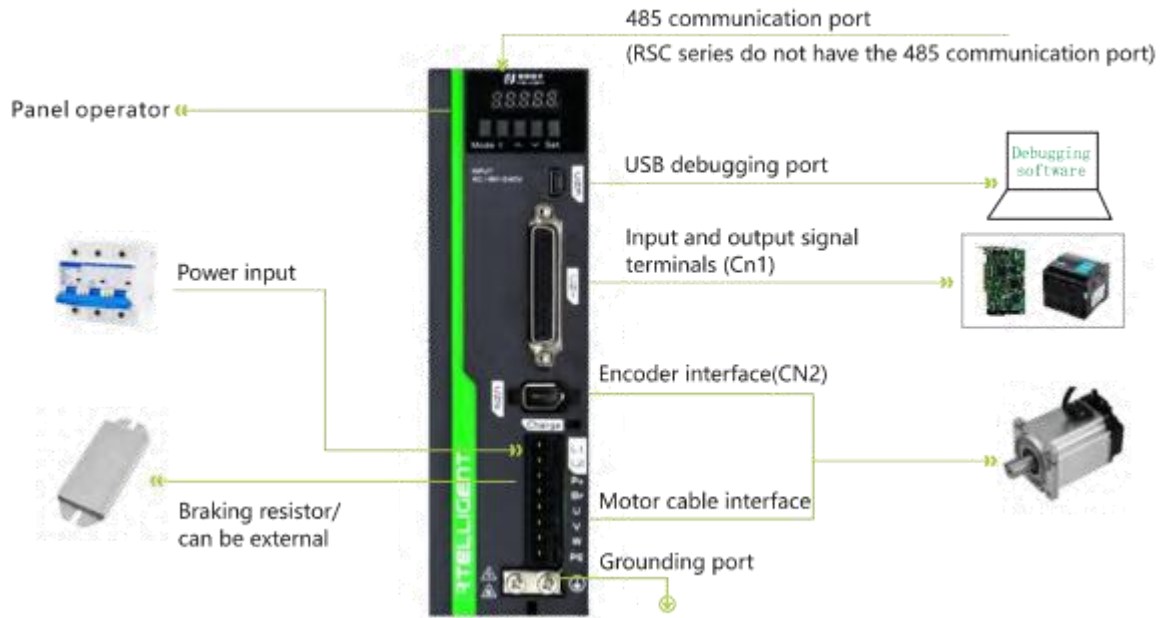

4.2. Power Port

Pin	Definition	Detail
L1、L2、L3	Power supply input terminal	Servo driver power supply input terminal, single-phase 220VAC or three-phase 220VAC
P+、Br	Braking resistor terminal	Connect to energy consumption braking resistor
U、V、W、PE	Servo Motor connection terminal	Servo motor connection terminals, must be connected to the U, V, W, and PE terminals of the motor

Circuit wiring Precautions:

- ◆ Do not connect the input power cable to the output terminals U, V, W, otherwise the servo drive will be damaged.
- ◆ Do not pass the power cable and signal cable through the same pipe or bundle them together. To avoid interference, the distance between them should be more than 30cm.
- ◆ Do not turn on/off the power frequently. When you need to repeatedly turn on/off the power continuously, please control it to less than once a minute. Since the power supply part of the servo drive has a capacitor, when the power is turned on, a relatively large charging current will flow (charging time 0.2s). Frequent ON/OFF of the power supply will cause the performance of the main circuit components inside the servo drive to degrade.

- ◆ Please connect the servo drive to the ground reliably, and the PE wire should be as thick as possible to ensure that the grounding resistance is less than 100Ω.
- ◆ It is recommended that the power supply be supplied through a noise filter to improve the anti-interference ability.
- ◆ Please install a non-fuse type (NFB) circuit breaker so that the external power supply can be cut off in time when the drive error occurs.
- ◆ Do not power on and use the servo drive when the terminal screws or cables are loose, otherwise it may cause a fire.

4.3. Encoder Signal-CN2

1. Servo motor encoder output terminal signal definition

In the face of the motor encoder outlet terminal, the terminal definition is shown in the following diagram:

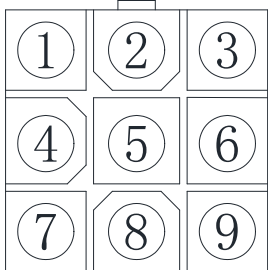
Servo motor encoder outlet terminal diagram			
	Signal	Pin	Definition
	FG	1	Shield ground
	+5V	2	Power input: +5V
	GND	3	Power input: 0V
	SD+	4	Encoder bus signal
	SD-	5	
	E+	6	Encoder battery
E-	7		

2. Servo encoder extension cable motor side terminal

In the face of the servo encoder extension cable motor side terminal, the terminal definition is shown in the following diagram:

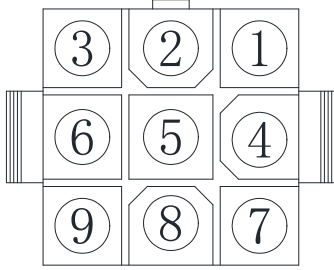
Servo encoder extension cable motor side terminal diagram			
	Signal	Pin	Definition
	FG	1	Shield ground
	+5V	2	Power output: +5V
	GND	3	Power output 0V
	SD+	4	Encoder bus signal
	SD-	5	
	E+	6	Encoder battery
E-	7		

3. Servo encoder extension cable drive side terminal

The servo encoder extension cable drive side terminal is a welding pin, which is marked with a pin serial number, and the definition serial number of its terminal is shown in the following diagram:

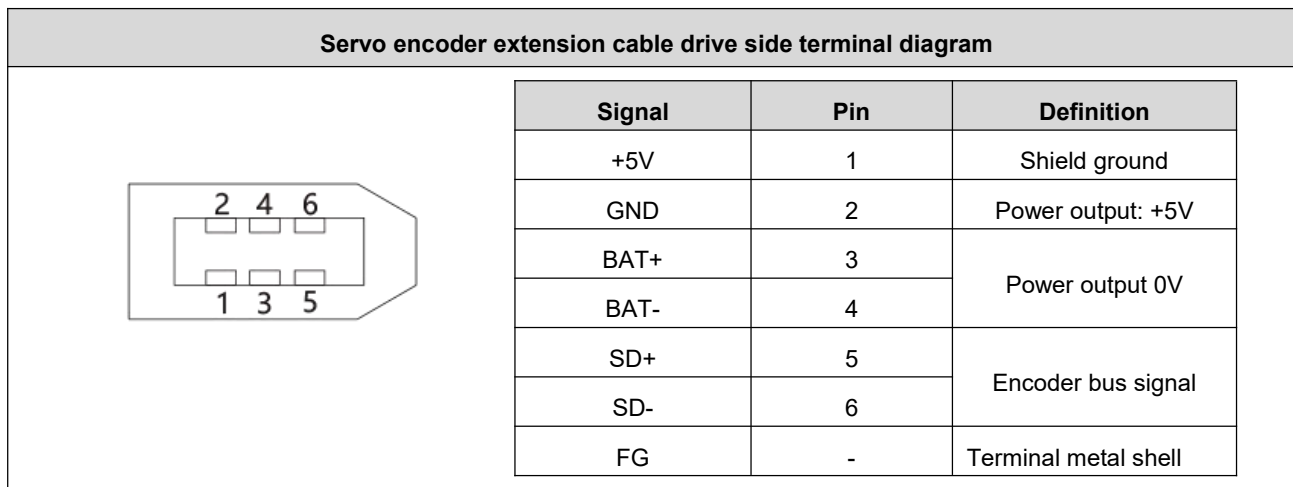

Remark:

- ◆ Please purchase intelligent the SE series cables or cables with the same specifications and above.
- ◆ The encoder cable should be as far away as possible from other high-current loops of the equipment to prevent interference.
- ◆ Do not place the encoder connector in the drag chain to prevent poor connection at the connector. The multi-turn absolute encoder wiring comes with two battery connectors. Please pay attention to the battery protection when purchasing.
- When cables are placed in the drag chain, attention should be paid to the distribution space to avoid excessive bending angles and the resulting reduction in cable life.

4.4. Control Signal-CN1

4.4.1. Pin Definition

CN1 is a 44-pin three-row DB connector, which is included with the drive when shipped. Please carefully confirm the pin definition and electrical specifications. The drive control signal terminal CN1 pin diagram is as follows:

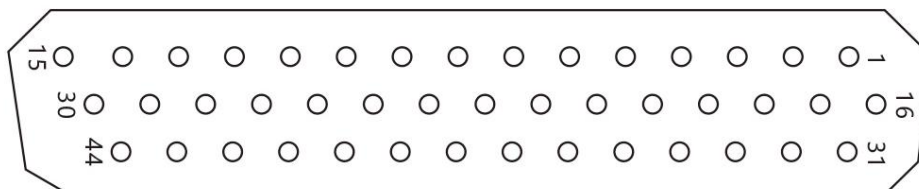

Function	Signal	Pin	Definition	Default function	Description
External pulse interface	PUL+	3	Differential pulse positive	-	Differential input, 5V
	PUL-	4	Differential pulse negative		
	DIR+	5	Differential direction positive		
	DIR-	6	Differential direction negative		
	24VPUL+	16	24V pulse positive		24V+
	24VDIR+	17	24V direction positive		
Universal input interface	IN1(SV-ON)	2	Input 1	Servo enable	Below 24V, support common anode or common cathode. Note: Does not support the mixed use of NPN and PNP.
	IN2(POT)	7	Input 2	Positive limit	
	IN3(NOT)	8	Input 3	Negative limit	
	IN4(ALMRST)	9	Input 4	Alarm clear	
	IN5(PULStop)	10	Input 5	Pulse prohibited	
	IN6(Home)	11	Input 6	Origin input	
	IN7(ZEROStart)	12	Input 7	Start homing	
	IN8(EMESop)	13	Input 8	Emergency stop	
	IN9(GAIN)	14	Input 9	Gain switching	
INCOM	1	Input common	-		
Universal common cathode output interface	OUT1(SV-RDY)	32	Output 1	Servo ready	Below 24V, common cathode output, current does not exceed 50mA.
	OUT2(INP)	33	Output 2	Positioning completed	
	OUT3(ALM)	34	Output 3	Alarm output	
	OUT4(ZERODONE)	35	Output 4	Homing completed	
	OUTCOM-	31	Output common	-	
Universal differential output interface	DFOUT5+(BRK+)	18	Output 5 positive	Brake	Below 24V, differential output, current does not exceed 200mA
	DFOUT5-(BRK-)	19	Output 5 negative		
	DFOUT6+(PULO+)	20	Output 6 positive	Internal command stop	
	DFOUT6-(PULO-)	21	Output 6 negative		
Encoder output interface	DFEA+	23	Encoder A+	-	5V differential output
	DFEA-	24	Encoder A-		
	DFEB+	25	Encoder B+		
	DFEB-	26	Encoder B-		
	DFEZ+	27	Encoder Z+		
	DFEZ-	28	Encoder Z-		

	EA	36	Single-ended EA	-	Collector output
	EB	37	Single-ended EB		
	EZ	29	Single-ended EZ		
	GND	30	Single-ended GND		
Analog input interface	AN1+	39	Analog channel 1+	-	-10V ~ +10V analog input
	AN1-	40	Analog channel 1-		
	AN2+	43	Analog channel 2+		
	AN2-	44	Analog channel 2-		
	ANGND	41	Analog channel GND		

4.4.2. Position Command Input Signal

◆ Note: Only RS pulse type/RS485 type drive can be connected with pulse input signal.

Signal	Pin	Definition	Description
PUL+	3	Differential pulse positive	Differential input 5V
PUL-	4	Differential pulse negative	
DIR+	5	Differential direction positive	
DIR-	6	Differential direction negative	
24VPUL+	16	24V pulse positive	Single-ended input 24V+
24VDIR+	17	24V direction positive	

1. Differential pulse signal

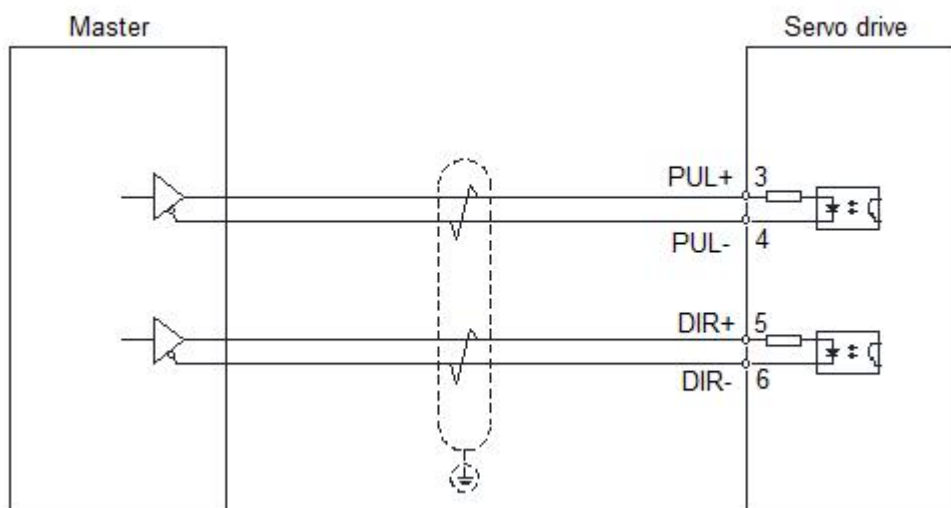

2. Single-ended common anode signal

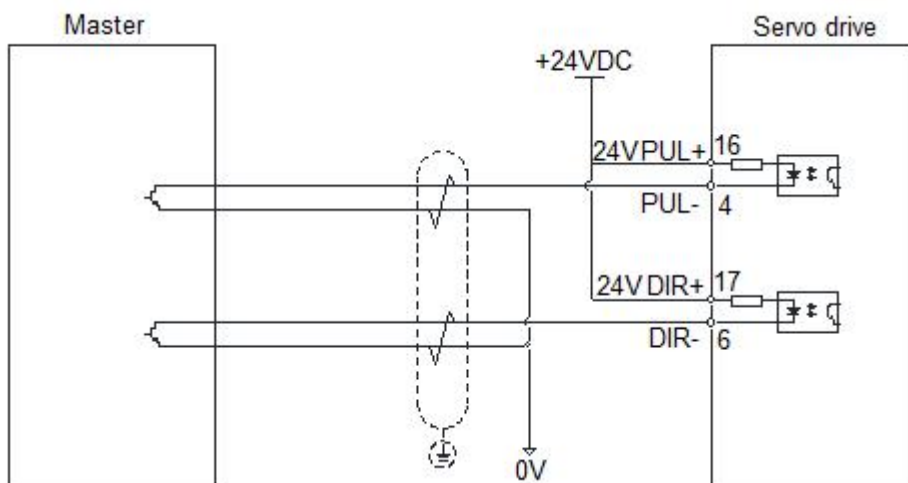

3. Single-ended common cathode signal

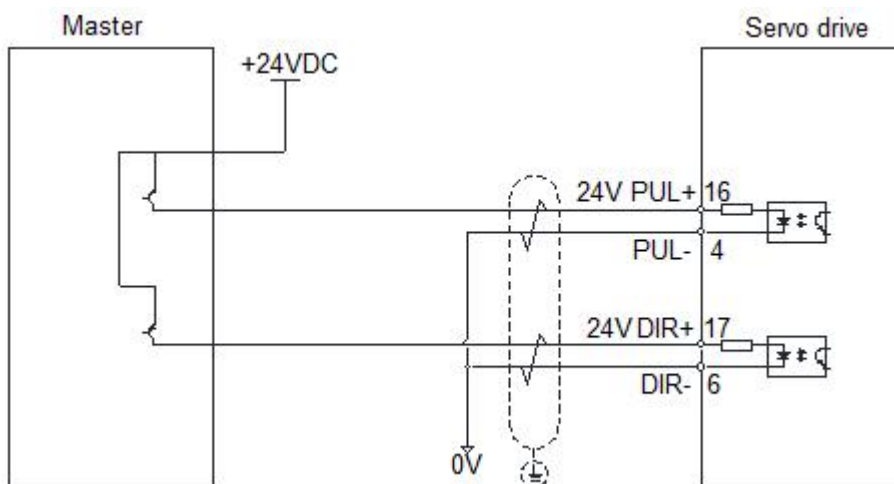

4.4.3. Digital Input Signal

Signal	Pin	Definition	Default function	Description
IN1(SV-ON)	2	Input 1	Servo enable	Below 24V, support common anode or common cathode. Note: Does not support the mixed use of NPN and PNP.
IN2(POT)	7	Input 2	Positive limit	
IN3(NOT)	8	Input 3	Negative limit	
IN4(ALMRST)	9	Input 4	Alarm clear	
IN5(PULStop)	10	Input 5	Pulse prohibited	
IN6(Home)	11	Input 6	Origin input	
IN7(ZEROStart)	12	Input 7	Start homing	
IN8(EMESStop)	13	Input 8	Emergency stop	
IN9(GAIN)	14	Input 9	Gain switching	
INCOM	1	Input common	-	

The drive has a total of 9 input ports. As shown in the figure above, the input uses a bidirectional optocoupler, which can support NPN and PNP switch signals.

The interface circuits of IN1~IN9 are the same, and the function can be selected and set according to P02.00~P02.17.

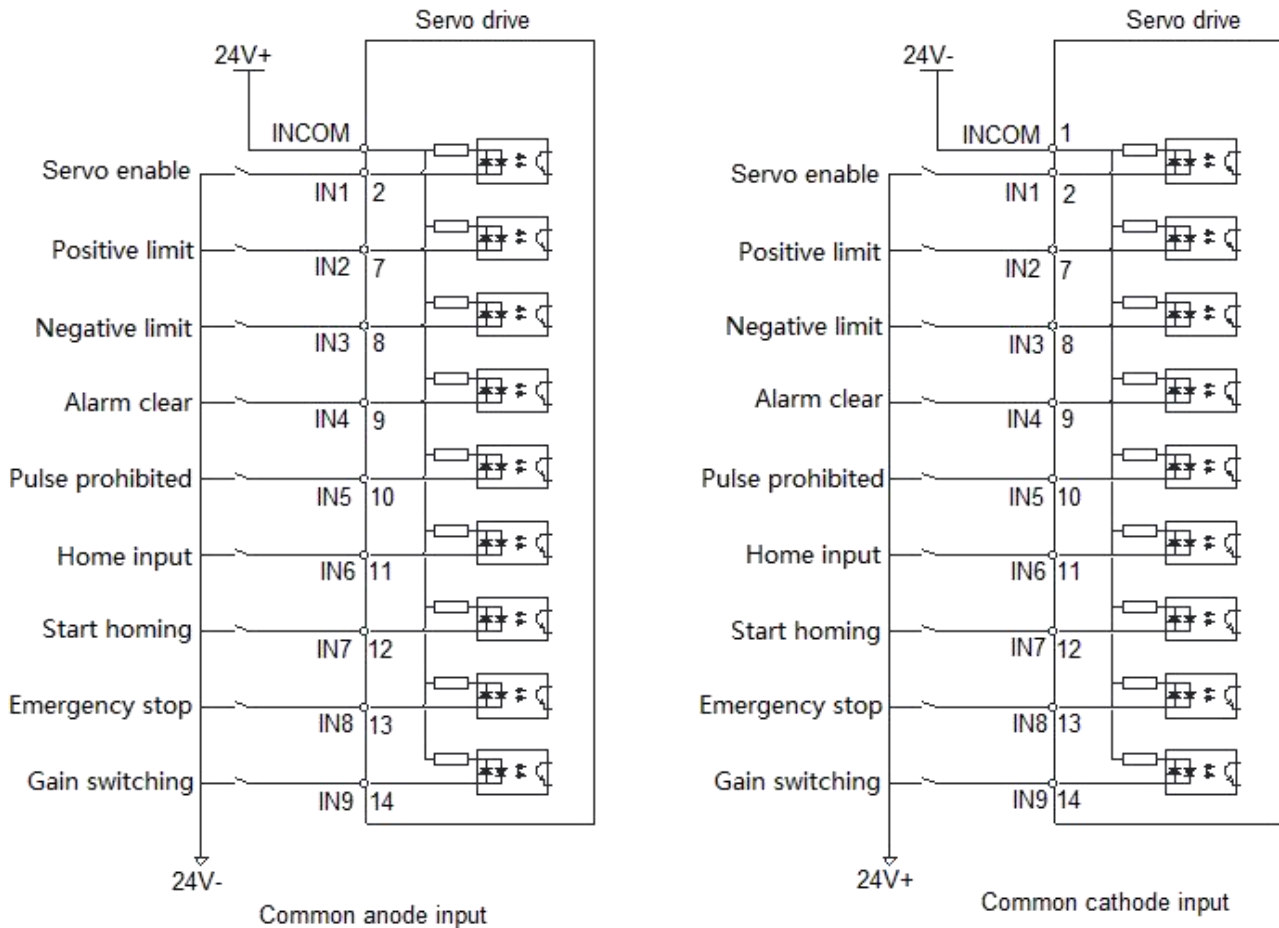

Take IN1 as an example, the wiring example is as follows:

1. When the upper computer device is a relay output:

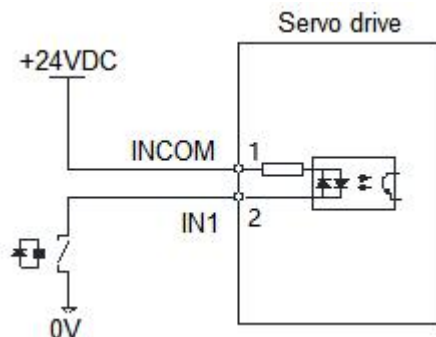

2. When the upper computer device is open-collector output:

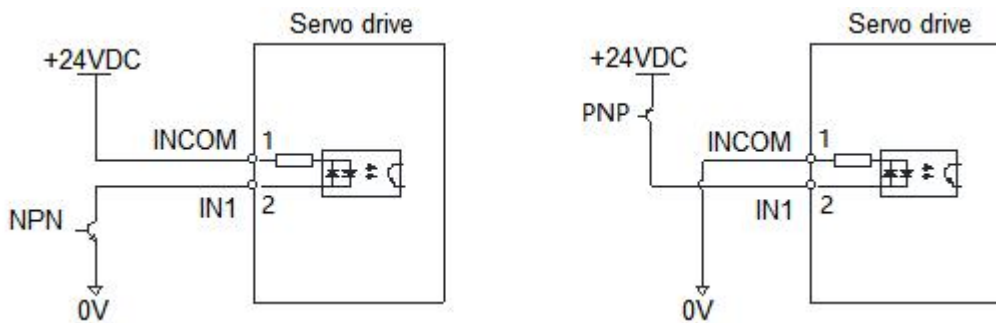

◆ Note: Mixing of NPN and PNP is not supported

4.4.4. Digital Output Signal

Signal	Pin	Definition	Default function	Description
OUT1 (SV-RDY)	32	Output 1	Servo ready	Below 24V, common cathode output, current does not exceed 50mA.
OUT2 (INP)	33	Output 2	Positioning completed	
OUT3 (ALM)	34	Output 3	Alarm output	
OUT4 (ZERODONE)	35	Output 4	Homing completed	
OUTCOM-	31	Output common	-	Below 24V, differential output, current does not exceed 200mA
DFOUT5+ (BRK+)	18	Output 5 positive	Brake	
DFOUT5- (BRK-)	19	Output 5 negative		
DFOUT6+ (PULO+)	20	Output 6 positive	Internal command stop	
DFOUT6- (PULO-)	21	Output 6 negative		

The drive has a total of six output ports, the common cathode output terminal drive current is 50mA, which can be used for small current output; the maximum drive current of the differential output terminal is 200mA, which can be used to drive the relay type output.

1. The OUT1~OUT4 interface circuits are the same. Take OUT1 as an example.

(1) When the upper computer device is a relay output

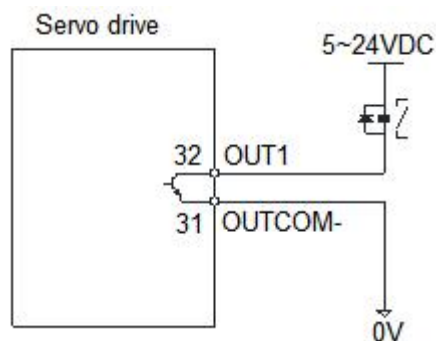

The following is the wrong wiring method

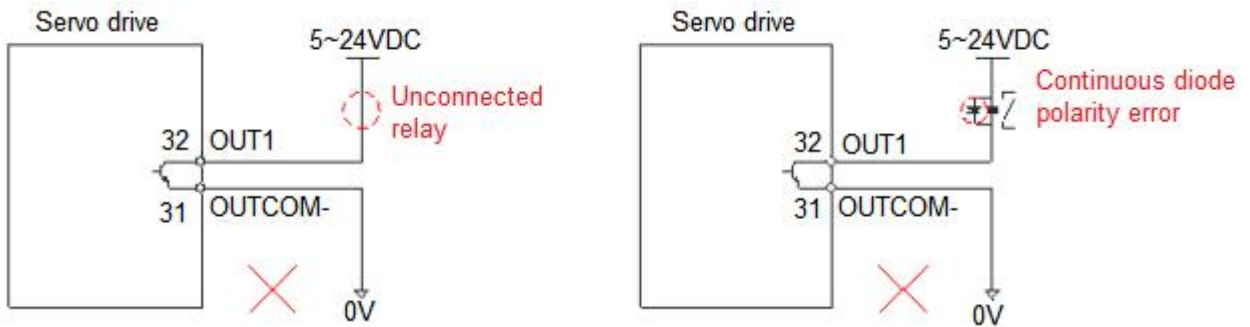

(2) When the upper device is optocoupler input

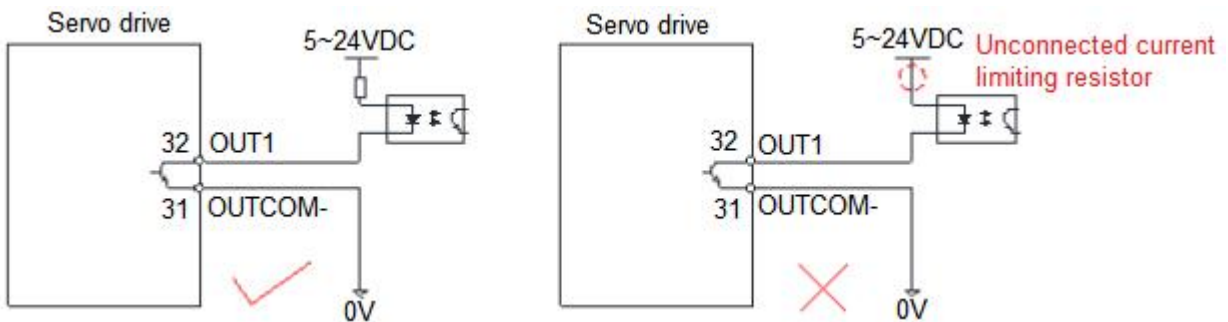

2. The OUT5~OUT6 interface circuits are the same. Take OUT5 as an example.

(1) When the upper device is a relay input

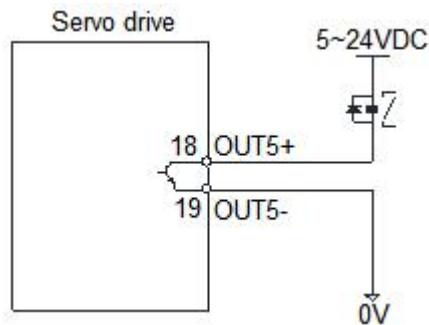

The following is the wrong wiring method

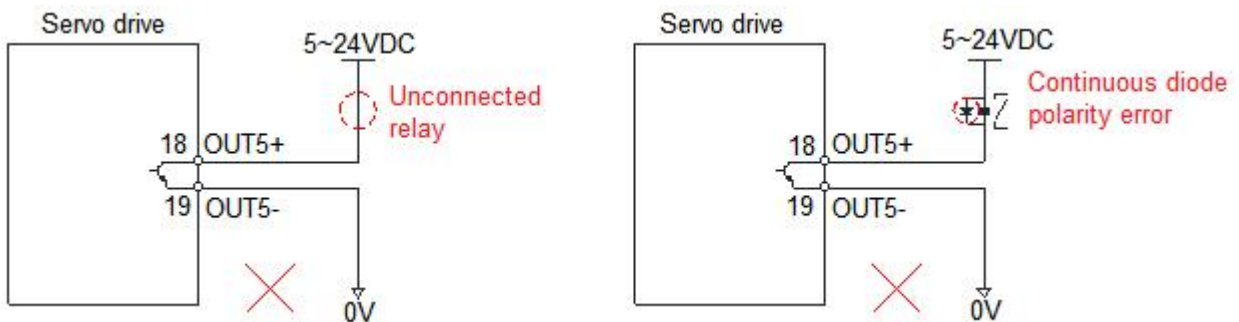

(2) When the upper device is optocoupler input

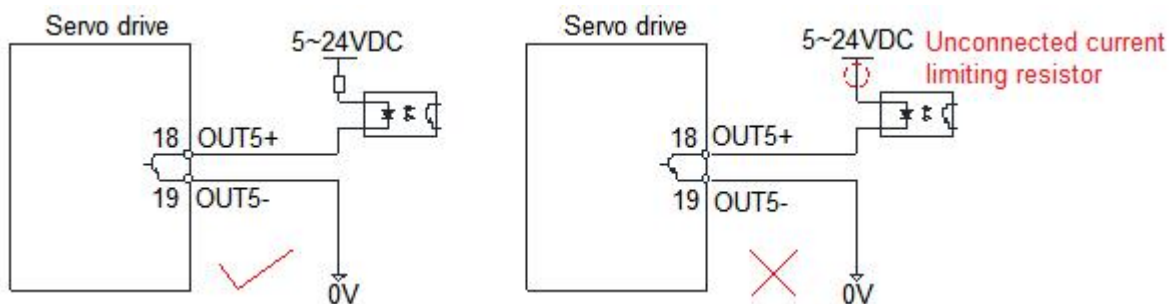

4.4.5. Analog Input Signal

Signal	Pin	Definition	Default function	Description
AN1+	39	Analog channel 1 +	-	-10V ~ +10V analog input
AN1-	40	Analog channel 1 -		
AN2+	43	Analog channel 2 +		
AN2-	44	Analog channel 2 -		
ANGND	41	Analog GND	-	

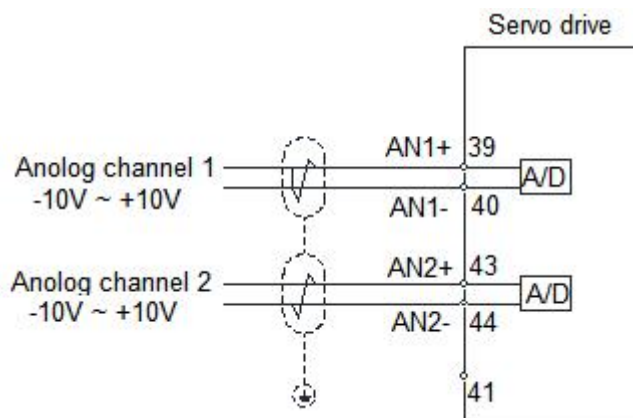

4.4.6. Encoder Output Signal

Signal	Pin	Definition	Default function	Description
DFEA+	23	Encoder A+	-	5V differential output
DFEA-	24	Encoder A-		
DFEB+	25	Encoder B+		
DFEB-	26	Encoder B-		
DFEZ+	27	Encoder Z+		
DFEZ-	28	Encoder Z-		
EA	36	Single-ended EA	-	Collector output
EB	37	Single-ended EB		
EZ	29	Single-ended EZ		
GND	30	Single-ended GND	-	

1. Encoder differential output

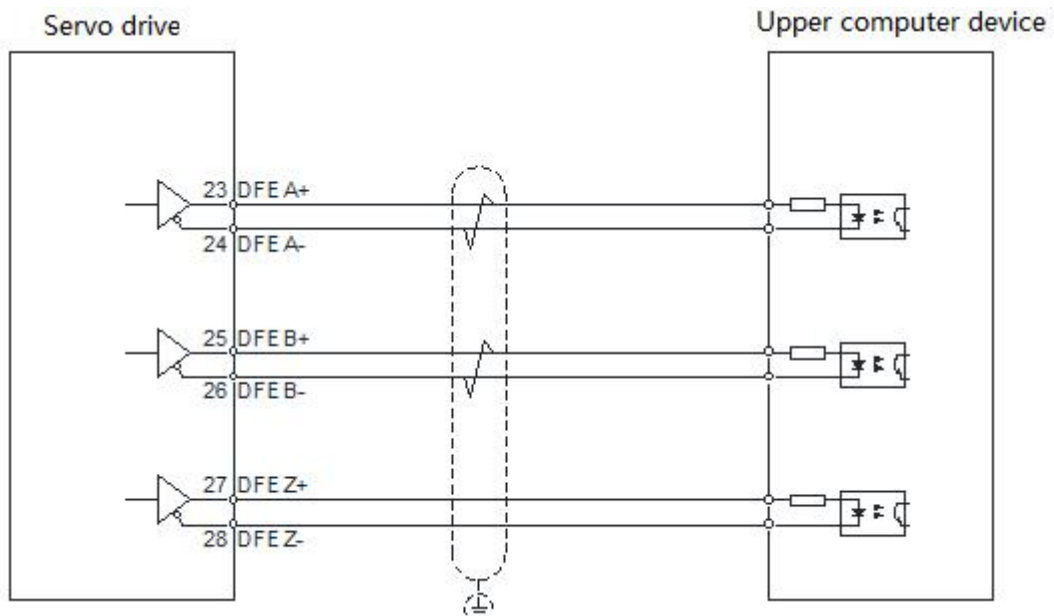

2. Encoder collector output

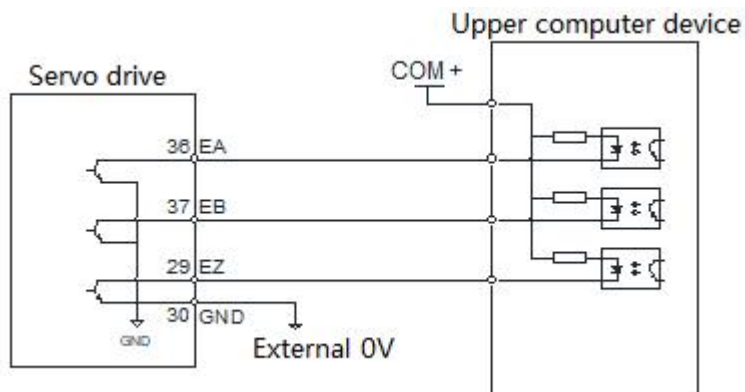

4.4.7. Motor Brake Wiring

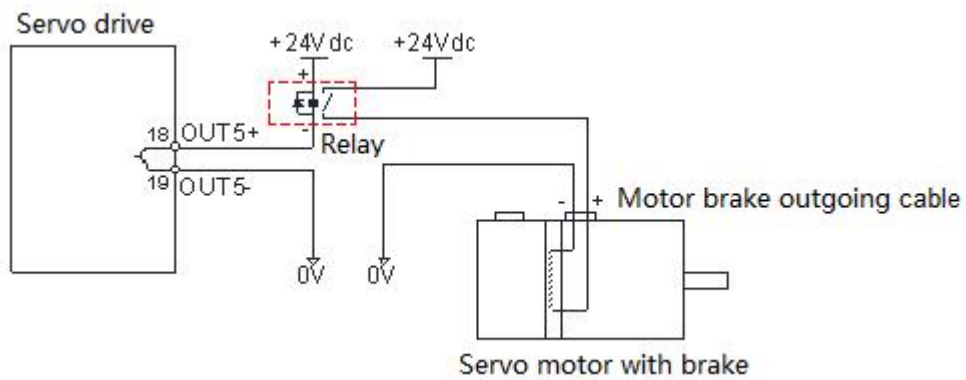

4.5. Anti-interference Countermeasures for Electrical Wiring

1. To suppress interference, please take the following measures

- ◆ The length of the command input cable should be less than 3m, and the encoder cable should be less than 20m.
- ◆ Use thick wires as much as possible for the grounding wiring. (Above 2.0mm²)
- ◆ Please use a noise filter to prevent radio frequency interference. When using in a civil environment where the power supply interference noise is strong, please install a noise filter on the input side of the power cord.

2. In order to prevent the malfunction caused by electromagnetic interference, the following treatment methods can be used

- ◆ Install the host computer device and noise filter near the servo drive as much as possible.
- ◆ Install surge suppressors on the coils of relays, screw tubes, and electromagnetic contactors.
- ◆ When wiring, please lay the strong current cables separately from the weak current cables, and keep an interval of more than 30cm. Do not put them in the same pipe or bundle them together.
- ◆ Do not share power supply with electric welders, electrical discharge processing equipment, etc. When there is a high-frequency generator nearby, install a noise filter on the input side of the power cord

5. Control Panel

5.1. Panel Overview

5.1.1. Panel Composition Introduction

The display panel of the servo drive is composed of 5 keys and a 5-digit LED digital tube display, which is used to realize various status information display, trial operation, parameter management and other functions. The 5 keys are identified as follows:

Function	Symbol	Description	Icon
Mode/return	MODE	Mode switch	
Shift key	◀	Shift left	
Increase	▲	Switch up selection/increase value	
Decrease	▼	Switch down selection/decrease value	
Confirm	SET	Confirm operation	

5.1.2. Panel Display Content

When the servo drive is running, the LED display can be used for servo monitoring display, parameter display, function display, parameter management, encoder adjustment, and open loop operation.

- ◆ Monitoring display: display the current running status of the servo
- ◆ Parameter display: display the set value of servo control parameters
- ◆ Function display: internal test run operation
- ◆ Parameter management: used to manage servo control parameters
- ◆ Encoder adjustment, open loop operation: the manufacturer reserves this function

5.1.3. Panel Operation

The operation of the control panel of the servo drive is shown in the figure below:

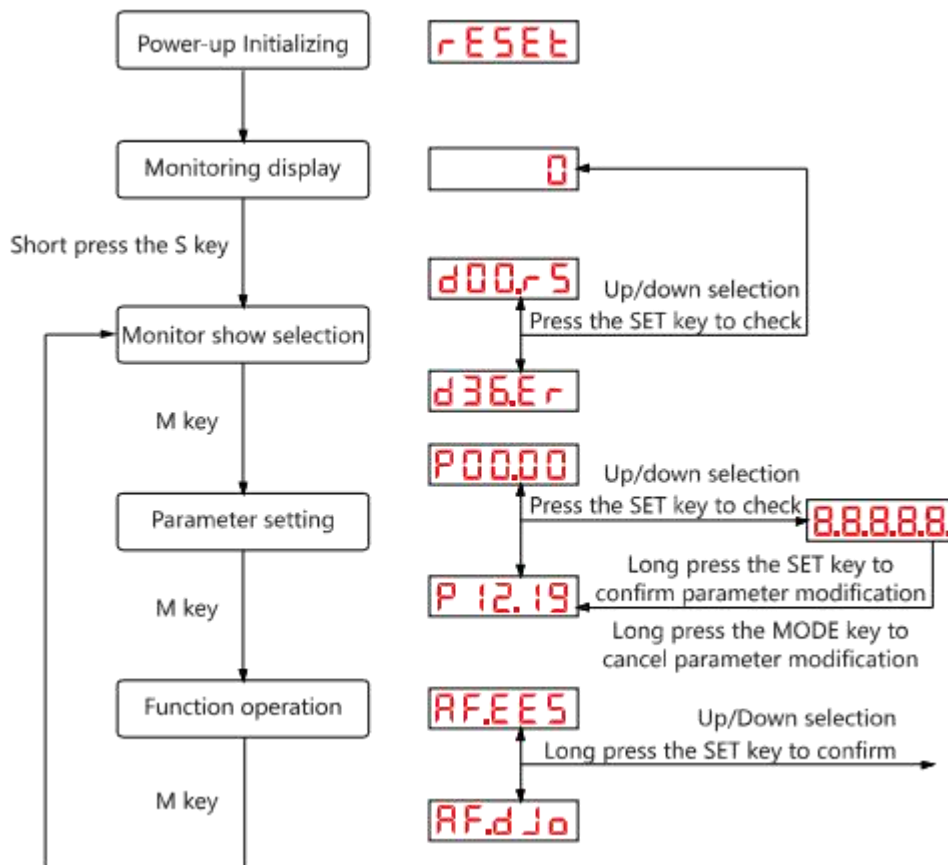

Remark:

- ◆ After the power is turned on and the initialization of the servo drive is completed, the panel display immediately enters the monitor display mode. The target parameter of pre-monitoring can be selected through parameter P01.35.
- ◆ Short press the "MODE" key to switch between different display modes.
- ◆ Once a fault occurs, the servo drive automatically displays the fault monitoring code.

5.1.4. Data Display

Different data length and negative number display description:

1. 4 or less digits signed number or 5 or less digits unsigned number

A single-page digital tube (5 digits) is used for display. For signed numbers, the highest digit of the data "-" indicates a negative sign.

(1) Display example: -6666 is displayed as follows:

-6666

(2) Display example: 65535 is displayed as follows:

65535

2. 4 or more digits signed number or 5 or more digits unsigned number

Display in pages from low to high by digits, each 4 digits is a page, display method: current page + current page value, switch the current page by long pressing the M key.

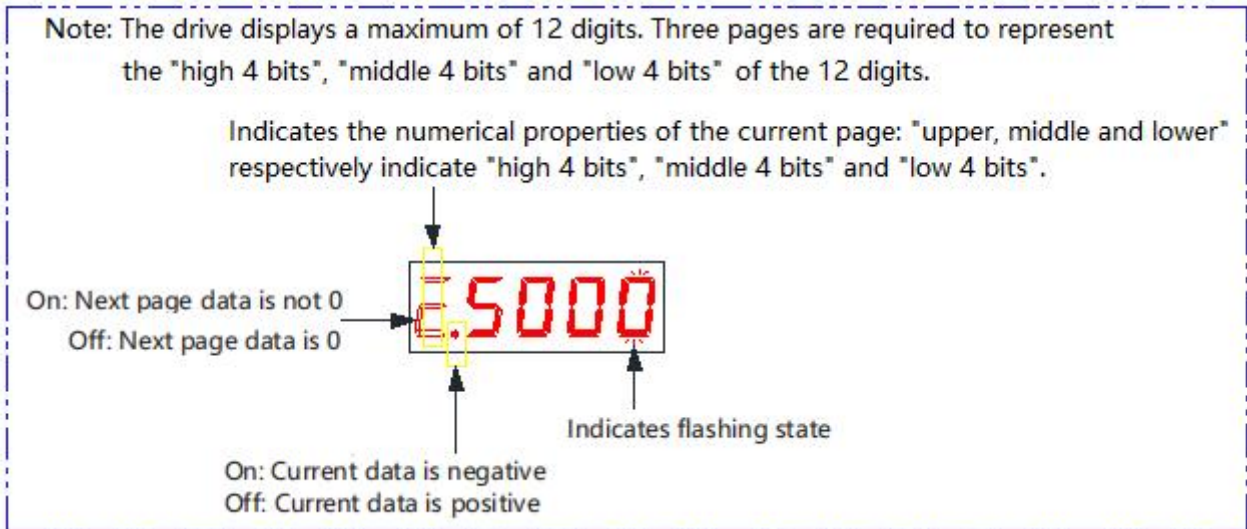

(1) Display example: 1073741824 is displayed as follows:

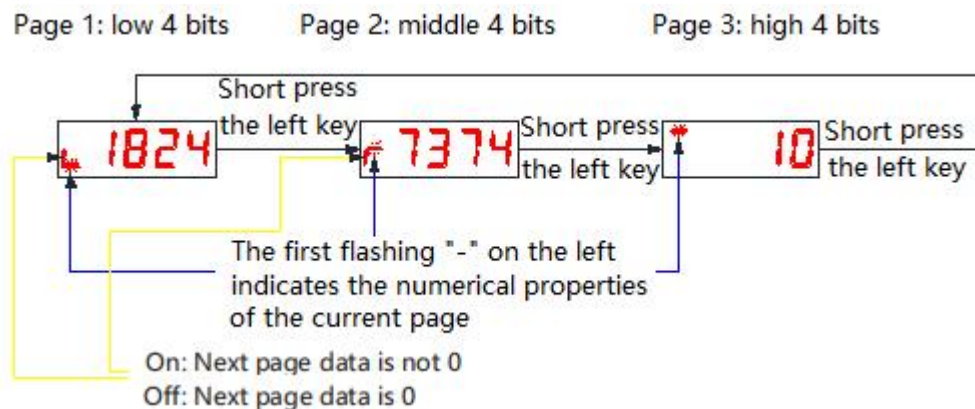

(2) Display example: -1073741824 is displayed as follows:

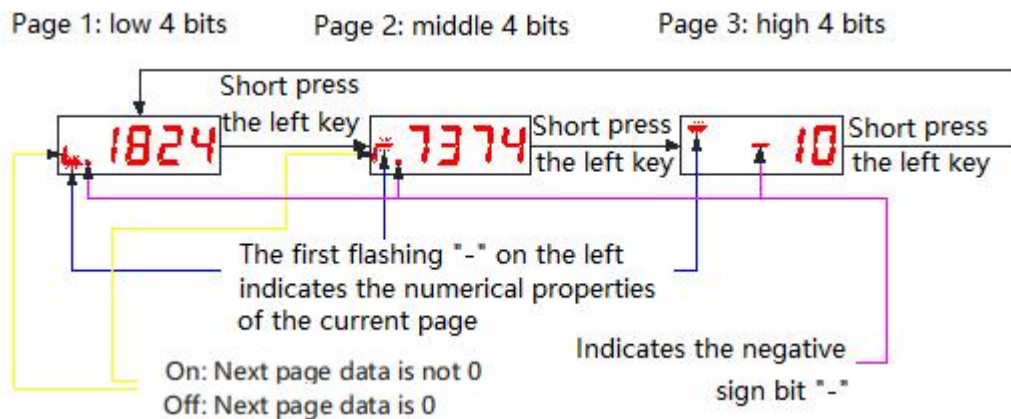

5.1.5. Fault Display

When the drive is in an error state, the LED panel can display related failure information. If the drive generates multiple fault alarms at the same time, the drive panel will jump to display each alarm in turn, or you can view it through the "up and down keys" on the debugging panel.



◆ For specific troubleshooting, please refer to the relevant content in [chapter 9](#).

5.1.6. Monitor Display

The monitor display is used to monitor the operation status of the servo drive. By setting the parameter code P01.35 (the panel default monitoring object), when the servo drive is powered on and initialized, the display will show the monitoring value of the object. The detailed description of the monitoring display is as follows:

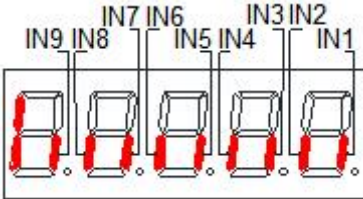
Display status	Description	Unit
d00.r5	Operation status	-
d01.5F	Motor speed	rpm
d02.5C	Speed command	rpm
d03.tF	Motor torque	%
d04.tC	Torque command	%
d07.PC	Position command counter	Command unit
d09.PC	Position feedback counter	Encoder unit
d11.PF	Feedback pulse counter	Encoder unit
d13.PE	Position error	Command unit
d15.PE	Position error	Encoder unit
d17.FS	Pulse command speed	rpm
d18.Fr	Pulse command frequency	KHz
d19.15	<p>Indicates the status of the current drive input port:</p> <ul style="list-style-type: none"> ◆ The corresponding LED segment code is "on", indicating that the port has signal input ◆ The corresponding LED segment code is "off", indicating that the port has no signal input 	-

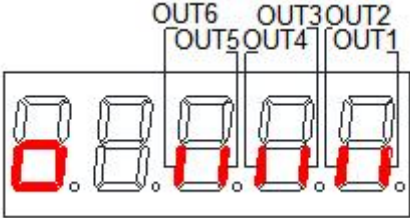
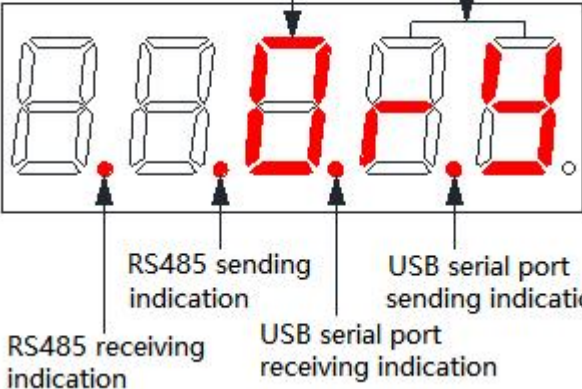
<p>d20.o5</p>	<p>Indicates the current status of the drive output port</p> <ul style="list-style-type: none"> ◆ The corresponding LED segment code is "on", indicating that the port signal output is valid ◆ The corresponding LED segment code is "off", indicating that the port signal output is invalid 	<p>-</p>
<p>d21.nA</p>	<p>Motor mechanical angle</p>	<p>Encoder unit</p>
<p>d22.eA</p>	<p>Motor electrical angle</p>	<p>°</p>
<p>d23.uV</p>	<p>Drive bus voltage</p>	<p>V</p>
<p>d24.eS</p>	<p>Encoder status</p>	<p>-</p>
<p>d25.Eo</p>	<p>Encoder single-turn value</p>	<p>Encoder unit</p>
<p>d26.En</p>	<p>Encoder multi-turn value</p>	<p>Circle</p>
<p>d27.Er</p>	<p>Encoder offset</p>	<p>Encoder unit</p>
<p>d28.PF</p>	<p>Feedback pulse counter</p>	<p>Command unit</p>
<p>d29.CS</p>	<p>Status indication:</p> <p>Control mode display 0: Position control mode 1: Speed control mode 2: Torque control mode</p> <p>Servo status display nr: not ready ry: ready rn: run</p> 	<p>-</p>
<p>d36.Er</p>	<p>Alarm code</p>	<p>-</p>

5.2. Parameter Setting

Use the panel of the servo drive to set the parameters. For parameter details, please read "[Chapter 7 Parameter Description](#)".

Take the LED display panel display parameter menu as an example, change the servo drive P03.06 (Number of position commands for one motor rotation) from the default value of 10000 to 5000 as an example, and proceed with the operation instructions:

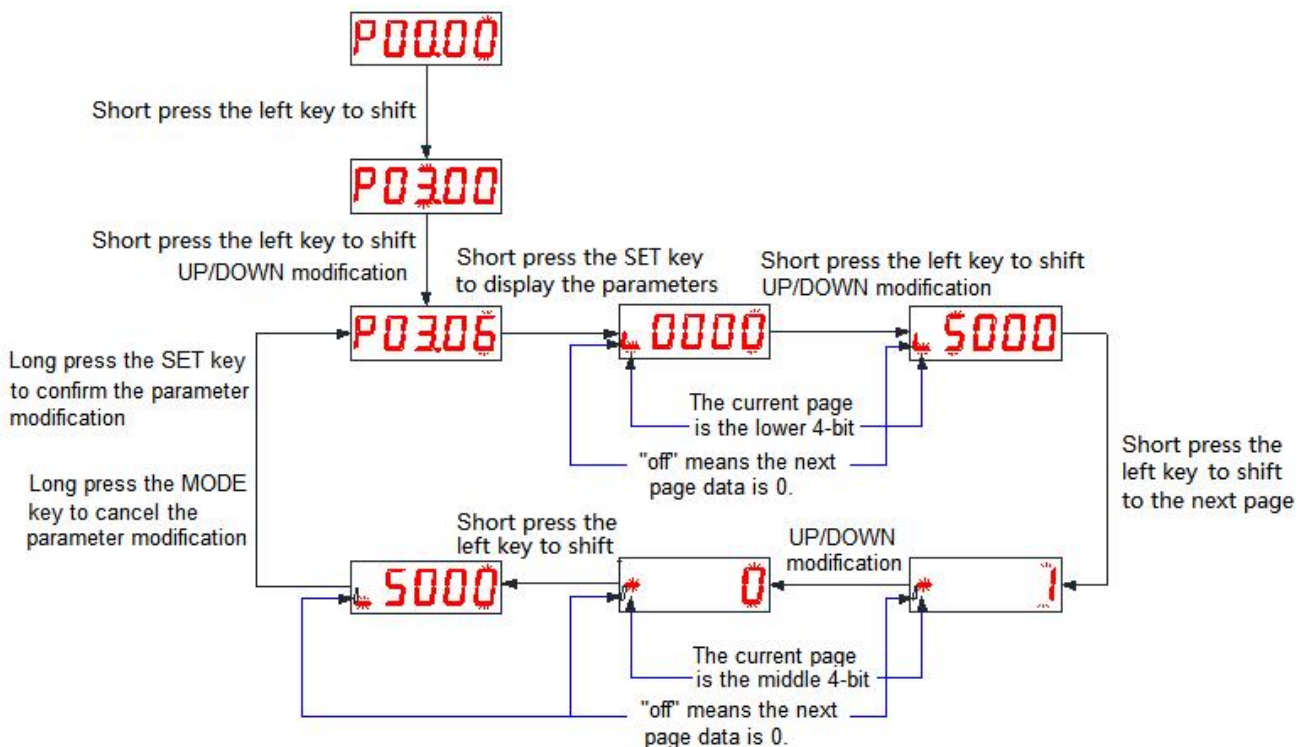

Remark:

- ◆ The modified parameters are only sent to the RAM area of the drive, and the value before the modification will be restored after the drive is powered off and restarted. After confirming the correctness of the parameter, if you need to save the parameter value permanently, you need to perform the "Save parameters" operation on the auxiliary function operation interface.

5.3. Auxiliary Function

5.3.1. Parameter Management

1. Save parameters

The parameters modified by the user through the "parameter setting" interface or the upper computer are only changed in the memory and will be lost after power off. If you want to change the parameters permanently, you need to execute the "save parameters" operation to write the internal parameters of the chip into the EEPROM inside the servo drive, and the modified parameter values will be used after power-on.

2. Read parameters

Read the parameters stored in EEPROM into the chip memory. This parameter is automatically executed once when the drive is powered on. Therefore, the parameter value in the chip memory is the same as the parameter value in the EEPROM at the beginning of power-on. When the user is not satisfied with the modified parameters or the parameters are adjusted disorderly, execute this operation to read the parameters in the EEPROM into the chip memory and restore the parameters at the time of power-on.

3. Reset

The factory default values of all parameters are read into the chip memory and written into the EEPROM. The default parameter values will be used next time the power is turned on. When the user parameters are disordered and the servo drive cannot work normally, all parameters can be restored to the factory default values through this operation.

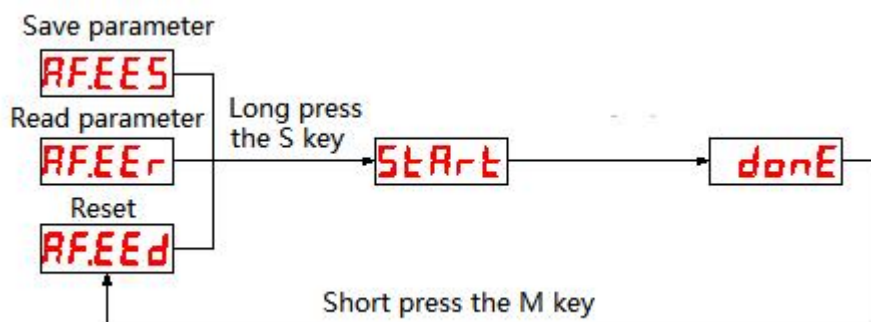

5.3.2. Fault Reset

When a resettable fault or warning occurs to the servo drive, the fault information of the servo drive can be reset without power failure, so that the servo drive can resume normal working mode.

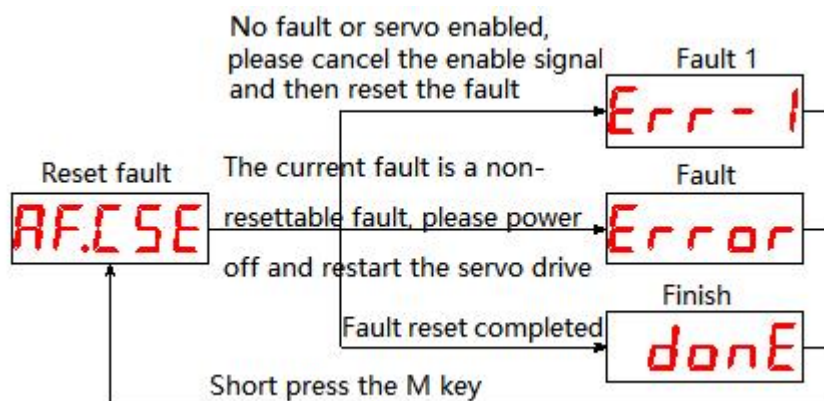

- ◆ Note: When using this operation, please disable the servo enable signal, otherwise the fault information cannot be reset.

5.3.3. Absolute Value Operation

This auxiliary function can be used to complete the task when a multi-turn encoder failure occurs or the multi-turn data of the absolute encoder needs to be cleared.

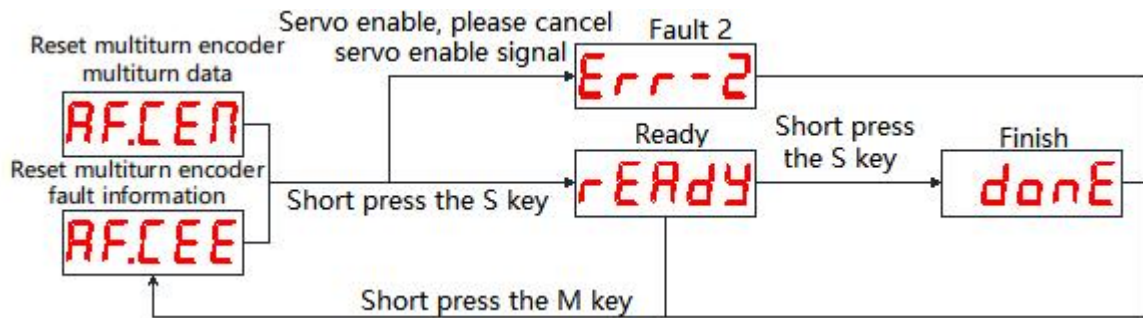

- ◆ Note: When using this operation, please disable the servo enable signal, otherwise the fault information cannot be reset.

5.3.4. Jog Test Machine

Through this operation, the servo drive can be tested.

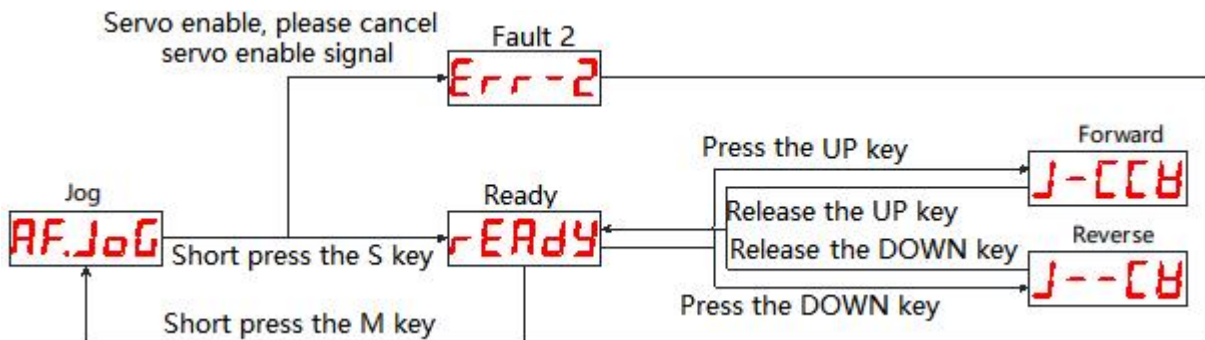

- ◆ Note: When using this operation, please disable the servo enable signal.

5.3.5. Open Loop Test

This function is only used for manufacturer testing, please do not operate.

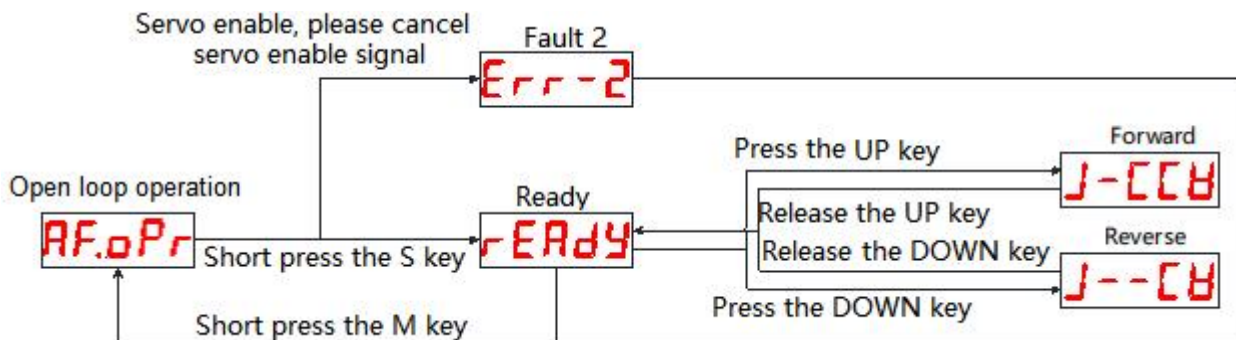

- ◆ Note: When using this operation, please disable the servo enable signal.

5.3.6. Encoder Calibration

This function is only used for manufacturer testing, please do not operate.

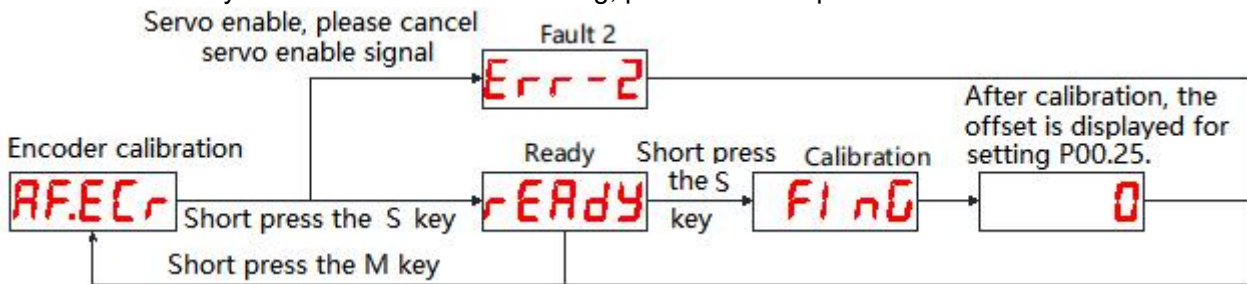

◆ Note: When using this operation, please disable the servo enable signal.

5.3.7. Jog Operation

Control the mode and speed of test operation by setting parameters P01.00 (Control mode), P04.62 (Speed), P04.63 (Acceleration time) and P04.64 (Deceleration time).

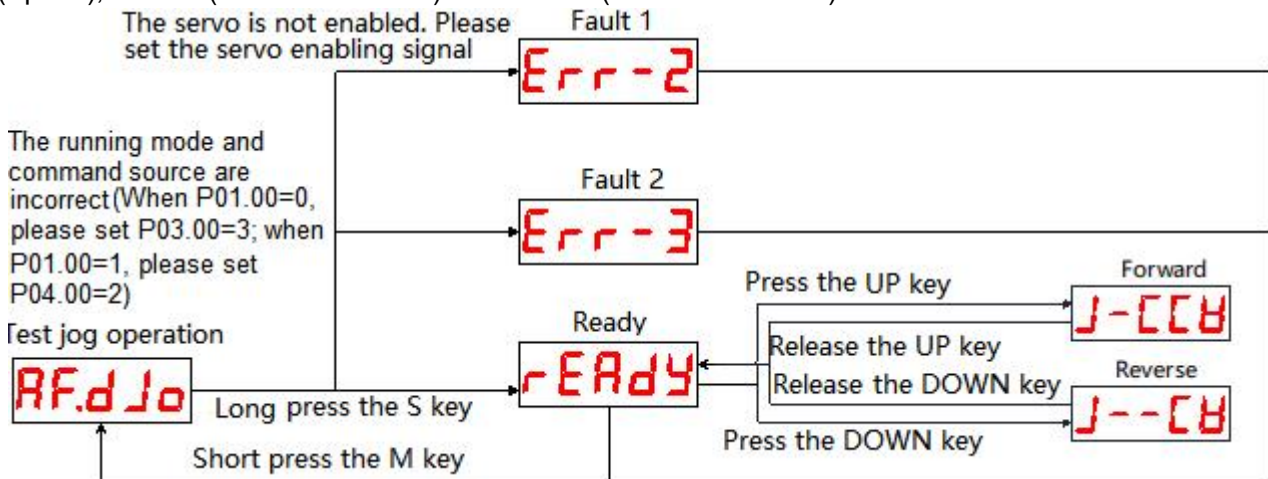

5.3.8. Fixed-length/Continuous Operation

The mode, speed, and stroke of the test operation are controlled by setting parameters P01.00 (Control mode), P04.60/P04.61 (Pulse command), P04.62 (Speed), P04.63 (Acceleration time) and P04.64 (Deceleration time).

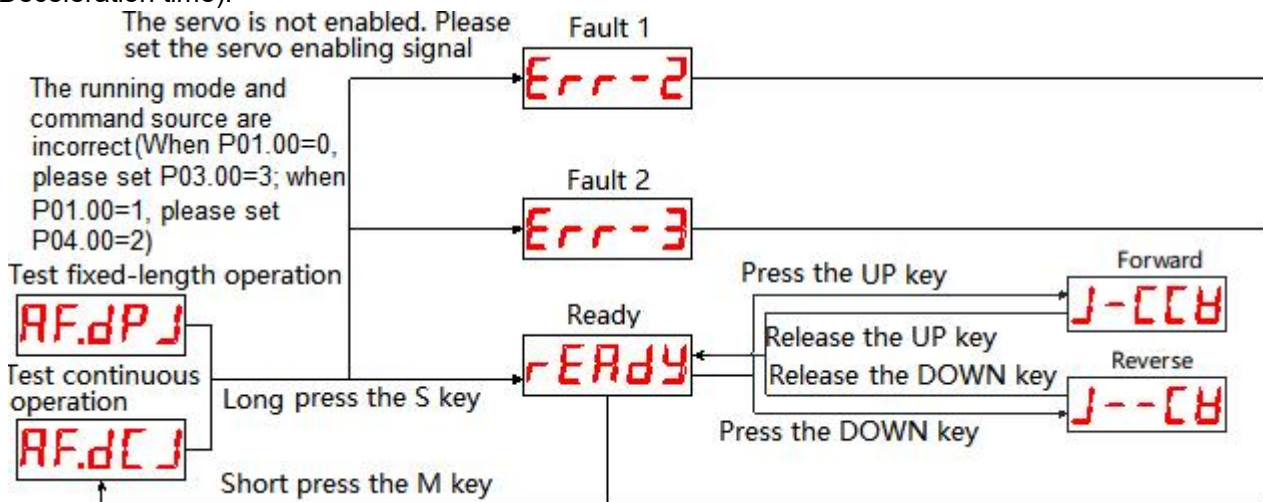

6. Control Mode

6.1. Position Control Mode

Position control mode is mainly used in occasions that require positioning control, such as manipulators, placement machines, engraving (Pulse train command), CNC machine, etc. Set the value of parameter P01.00 to 0 to enable the drive to work in position control mode.

6.1.1. Position Command Input Setting

In position control mode, the position command source should be set through P03.00 first.

★ Associated parameter description

Parameter	Name	Range	Function	Setting method	Effective time	Default
P03.00	Position command source	0: Pulse command 1: Step size 2: Multi-segment position command 3: Communication control 4: Communication control 2 5: IO control	Set the source of the position command. The pulse command is an external position command, and the others are internal position commands	Set after stopping	Effective immediately	0

1. The source of position command is pulse command (P03.00=0)





When setting the position command source as pulse command, it is necessary to correctly set the command type of external pulse according to the host computer or other pulse output device:

- ◆ Direction + pulse (positive logic or negative logic)
- ◆ A phase + B phase quadrature pulse, 4 times frequency
- ◆ Positive pulse / Negative pulse (CW + CCW)

★ Associated parameter description

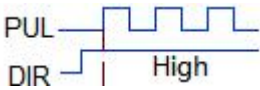
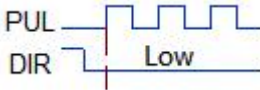
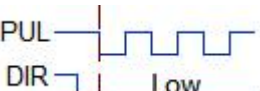
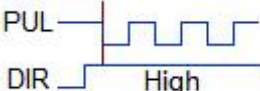
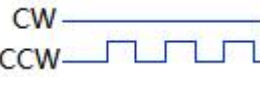
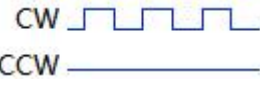
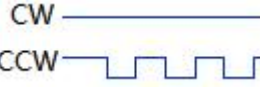
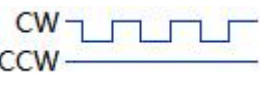
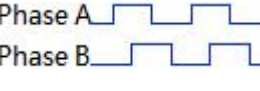
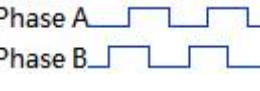
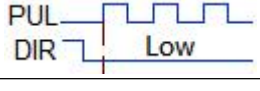
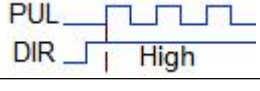
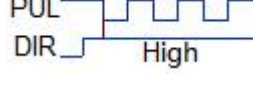
Parameter	Name	Range	Function	Setting method	Effective time	Default
P03.02	Pulse command type	0: Direction + pulse (positive logic) 1: Direction + pulse (negative logic) 2: CW + CCW 3: A phase + B phase quadrature pulse, 4 times frequency 4: CW + CCW	Select the type of external pulse command	Set after stopping	Save and restart	0

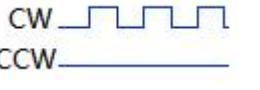
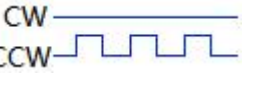
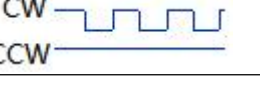
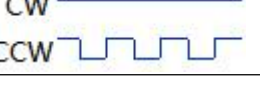
★ Description of pulse command types

P01.01 Rotation direction selection	P03.02 Command type setting	Command type	Signal	Schematic diagram of positive pulse	Schematic diagram of reverse pulse
0	0	Pulse + direction positive logic	PUL DIR		
	1	Pulse + direction negative logic	PUL DIR		
	2	CW+CCW	PUL(CW) DIR(CCW)		
					
3	A phase + B phase quadrature pulse 4 times frequency	PUL(A phase) DIR(B phase)	 ● Phase A ahead of phase B by 90°.	 ● Phase B ahead of phase A by 90°.	
1	0	Pulse + direction positive logic	PUL DIR		
	1	Pulse + direction negative logic	PUL DIR		
	2	CW+CCW	PUL(CW) DIR(CCW)		
					
3	A phase + B phase quadrature pulse 4 times frequency	PUL(A phase) DIR(B phase)	 ● Phase B ahead of phase A by 90°.	 ● Phase A ahead of phase B by 90°.	

2. The position command source is the step size (P03.00=1)

Under this position command source, there is a function that controls the fixed-length forward/reverse rotation of the motor through the external input terminal, the direction of operation is determined by the positive and negative signs of the pulse command stroke.

★ Associated parameter description

Parameter	Name	Range	Unit	Function	Setting method	Effective time	Default
P03.28 P03.29	Step size	-1073741824 ~ 1073741824	Command Unit	Set the stroke of the motor for fixed-length operation: Positive number means forward rotation Negative number means reverse rotation	Set when running	Next run	10000
P03.30	Step running speed	0~6000	r/min	Set the speed of the motor running at a fixed-length	Set when running	Next run	1000
P03.31	Step running acceleration time constant	1~65535	ms	Set the time for the motor to uniformly accelerate from 0r/min to 1000r/min at fixed-length	Set when running	Next run	200
P03.32	Step running deceleration time constant	1~65535	ms	Set the time for the motor to decelerate uniformly from 1000r/min to 0r/min at fixed-length	Set when running	Next run	200
P01.33	Emergency stop deceleration time constant	1~65535	ms	Set the time for the motor to decelerate uniformly from 1000r/min to 0r/min during emergency stop	Set when running	Next run	30

The startup mode is as follows:

Set the corresponding IN terminal Function to 13 (FunIN13: step position trigger), and confirm the valid logic of the IN terminal [Group P02: Terminal Input/Output Parameters](#)

★ Associated parameter description

Coding	Function name	Function
FunIN.13	Step position trigger	The servo running status is as follows: Valid: the motor runs the position command stroke set by parameter P03.28/P03.29. Invalid: the servo motor is in a locked state

FunIN.13 (step position trigger) is valid for edge trigger, the step position command is completed, and the servo motor enters the locked state; if FunIN.13 is triggered again, it is valid, and the servo motor will repeatedly execute the position command stroke set by P03.28/P03.29.

- ◆ Note: If the current position command of the motor does not stop running, it will not respond to the re-triggering signal. The user can receive the output signal (FunOUT. 5: internal position command shutdown) through the upper computer, which is used to determine whether the internal pulse of the servo drive has been sent, so as to determine the effectiveness of the second trigger.

3. The source of position command is multi-segment position command (P03.00=2)

The servo drive has multi-segment position operation function. It means that there are 16 position commands stored in the servo drive, and the displacement, maximum operating speed, acceleration and deceleration time of each segment can be set separately. The waiting time and connection mode between the segments can also be selected according to actual needs. The setting process is as follows:

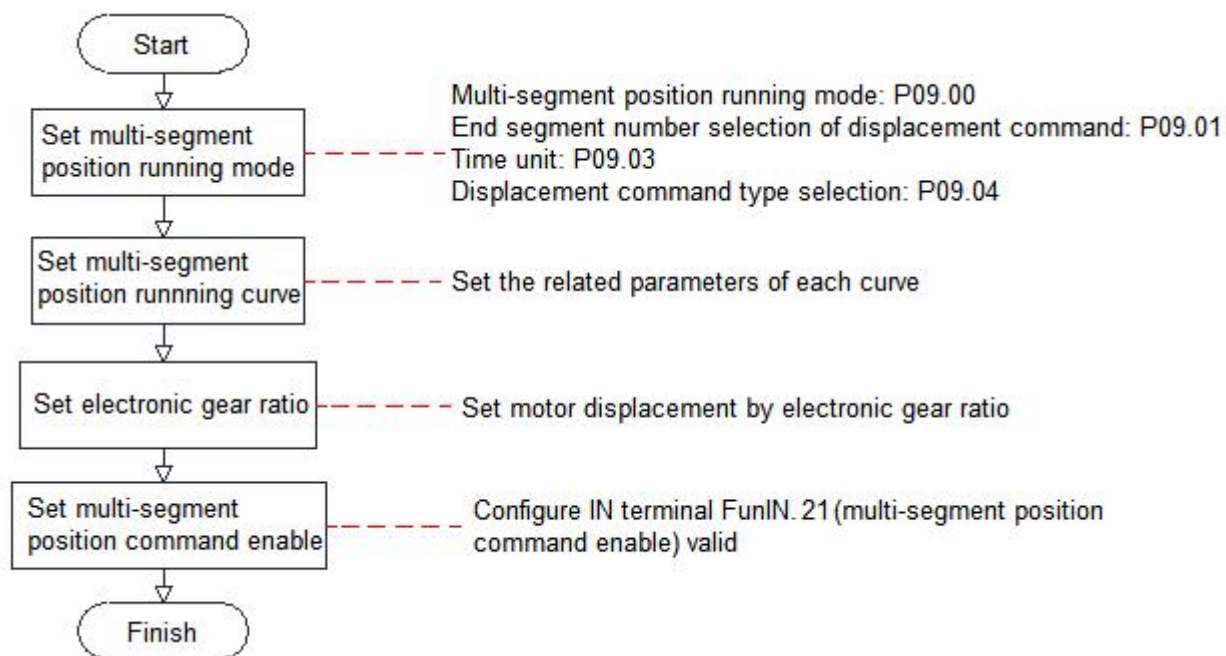

(1) Set multi-segment running mode

★ Associated parameter description

Parameter	Name	Range	Function	Setting method	Effective time	Default
P09.00	Multi-segment running mode	0: stop at the end of a single operation 1: Cycle operation 2: Switch through the external IN port	Set the connection mode between operation sections in multi-segment position	Set after stopping	Next run	1
P09.01	The number of end segments of position command	1~16	Set the total segments of the multi-segment position command	Set after stopping	Next run	1
P09.03	Waiting time unit	0: ms 1: s	Set the waiting time unit. Note: the waiting time is only valid when P09.00=0 or 1	Set after stopping	Next run	0
P09.04	Displacement command type selection	0: Incremental position command 1: Absolute position command	Set the type of multi-segment displacement command	Set after stopping	Next run	0

◆ Stop at the end of a single operation (P09.00=0)

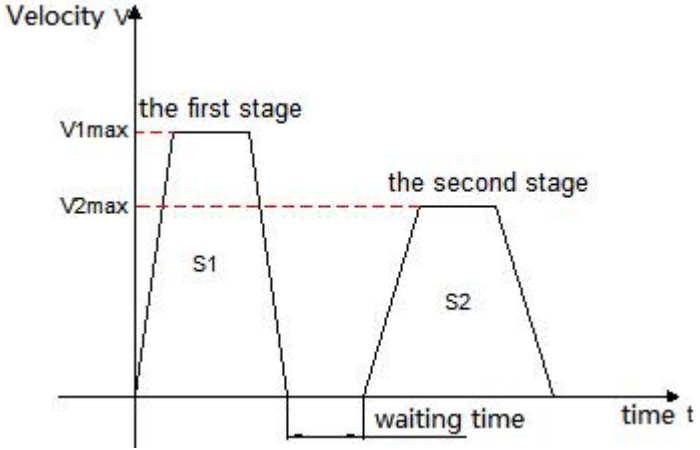
Mode description	Running curve
<ul style="list-style-type: none"> ● Run 1 round ● The segment number is automatically incremented and switched ● The waiting time can be set between each segment ● FunIN.21 (multi-segment position command enable) signal is level effective 	 <p>V1max、V2max: Maximum operating speed of the first and second segment S1、S2: Segment 1 and segment 2 displacement</p> <ul style="list-style-type: none"> ● After each segment of operation is completed, the motor's internal command stop signal output is valid. ● When the multi-segment position command is enabled OFF during operation, the driver gives up the uncompleted displacement of this segment and stops, and the positioning completion signal is valid after the stop is completed. ● Re-enable the multi-segment position command, and the driver will start to run sequentially from the first segment again.

★ Term explanation

The total number of multi-segment position commands set by P09.01 when the drive completes one run is called the completion of one round of operation.

◆ Cycle operation (P09.00=1)

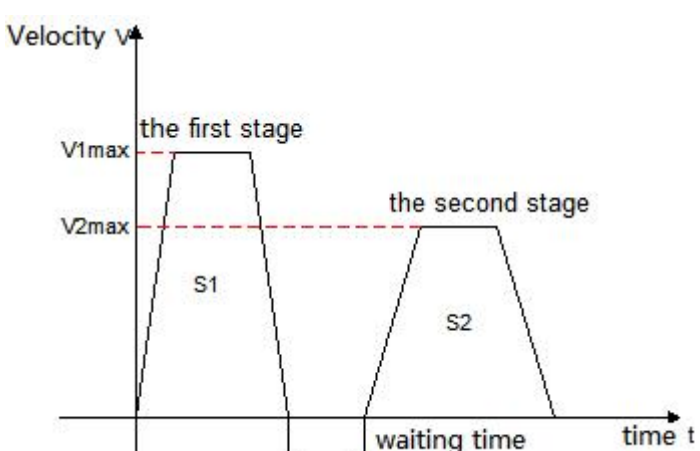
Mode description	Running curve
<ul style="list-style-type: none"> ● Cyclic running, the starting section number of each round is 1 ● The section number is automatically incremented switched ● Waiting time can be set between each segment ● FunIN. 21 (multi-segment position command enable) Signal is the level valid, and its signal is valid, and the drive will maintain the cyclic running state 	

	<p>V1max、V2max: Maximum operating speed of the first and second segment S1、S2: The first segment and the second segment displacement</p> <ul style="list-style-type: none"> ● After each segment of operation is completed, the motor's internal command stop signal output is valid. ● When the multi-segment position command is enabled OFF during operation, the driver gives up the uncompleted displacement of this segment and stops, and the positioning completion signal is valid after the stop is completed. ● Re-enable the multi-segment position command, and the driver will start to run sequentially from the first segment again.
--	--

◆ Switch through the external IN port (P09.00=2)

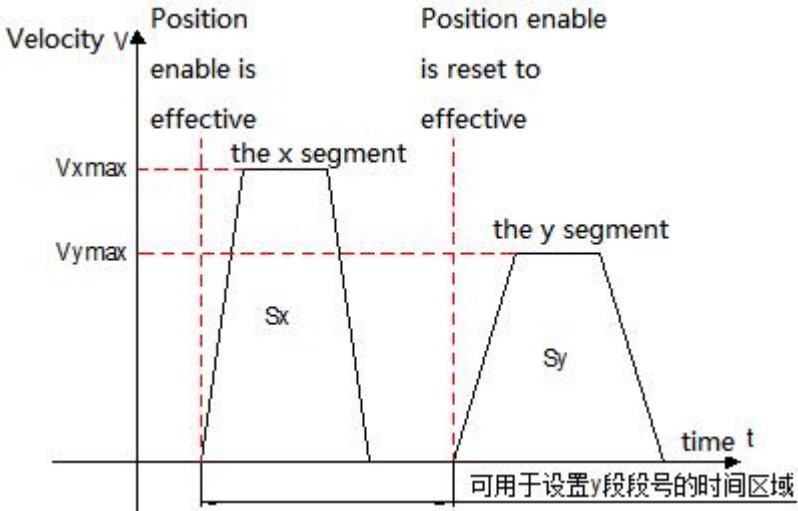
Mode description	Running curve
<ul style="list-style-type: none"> ● When running the current segment number, the next running segment number can be set, and the motor will stop after completing the position command set by the current segment number. After the multi-segment position command enable is set to ON again, run this time period number command ● The segment number is determined by the IN terminal logic ● There is no waiting time between each segment, the interval time is determined by the command delay of the host computer ● FunIN.21 (segment position command enable) signal is valid for edge change 	 <p>Vxmax、Vymax: Maximum operating speed of the x-th and y-th segment Sx、Sy: The x-th segment and the y-th segment displacement</p> <ul style="list-style-type: none"> ● After each stage of operation is completed, the internal command stop signal output of the motor is valid; ● During operation, the multi-segment position command enable is OFF, the driver continues to execute the unfinished displacement of this segment, and outputs the positioning completion signal ● The switching segment numbers must be in the following order: <ol style="list-style-type: none"> ①The segment number switch is invalid before the positioning of the x-th segment is completed ②During the x-th segment displacement operation or after the positioning is completed, turn off the multi-segment position command first, and then switch the segment number from x to y (if x=y, the driver will execute the x-segment displacement again) ③After the x-th segment displacement positioning is completed, the multi-segment position command enable is set to ON, and the driver executes the y-th segment displacement

When the multi-segment position operation mode is set to IN switching operation, please configure the 4 IN terminals of the drive (the number of IN terminals required can be set according to the actual number of running stages) as functions 14~17 (FunIN.13~FunIN.16: multi-segment position command switching), and confirm the valid logic of IN terminal.

★ Description of related coding function

Coding	Name	Function name	Function																														
FunIN.14	CMD1	Multi-segment running command switching 1	The multi-segment number is a 4-digit binary number, and the corresponding relationship between CMD1~CMD4 and the segment number is as follows: <table border="1" style="margin: 10px auto;"> <thead> <tr> <th>CMD4</th> <th>CMD3</th> <th>CMD2</th> <th>CMD1</th> <th>Segment</th> </tr> </thead> <tbody> <tr> <td>0</td> <td>0</td> <td>0</td> <td>0</td> <td>1</td> </tr> <tr> <td>0</td> <td>0</td> <td>0</td> <td>1</td> <td>2</td> </tr> <tr> <td colspan="5" style="text-align: center;">.....</td> </tr> <tr> <td>1</td> <td>1</td> <td>1</td> <td>0</td> <td>15</td> </tr> <tr> <td>1</td> <td>1</td> <td>1</td> <td>1</td> <td>16</td> </tr> </tbody> </table>	CMD4	CMD3	CMD2	CMD1	Segment	0	0	0	0	1	0	0	0	1	2					1	1	1	0	15	1	1	1	1	16
CMD4	CMD3	CMD2		CMD1	Segment																												
0	0	0		0	1																												
0	0	0		1	2																												
.....																																	
1	1	1	0	15																													
1	1	1	1	16																													
FunIN.15	CMD2	Multi-segment running command switching 2																															
FunIN.16	CMD3	Multi-segment running command switching 3																															
FunIN.17	CMD4	Multi-segment running command switching 4	The logic of the IN terminal is level valid, the CMD value is 1 when the input level is valid, otherwise it is 0																														

(2) Set multi-segment position running curve

The multi-segment position running function can set 16 different position commands, and the displacement, maximum running speed, acceleration and deceleration speed of each segment and the waiting time between segments can be set separately. Take the 1st segment as an example:

★ Associated parameter description

Parameter	Name	Range	Unit	Function	Setting method	Effective time	Default
P09.12 P09.13	Segment 1 moving displacement	-1073741824 ~ 1073741824	Command unit	Set the sum of position commands in the segment 1	Set when running	Next run	10000
P09.14	Maximum running speed of segment 1 displacement	0~6000	rpm	Set the maximum running speed of segment 1	Set when running	Next run	200
P09.15	Acceleration and deceleration time constant of segment 1 displacement	1~65535	ms	Set the time of constant speed change from 0rpm to 1000rpm for the segment 1 of motor in multi-segment position	Set when running	Next run	100
P09.16	Waiting time after the completion of segment 1 displacement	0~65535	ms(s)	Set the waiting time after the segment 1 positioning is completed	Set when running	Next run	100

According to the above settings, the actual running curve of the motor is shown in the figure below:

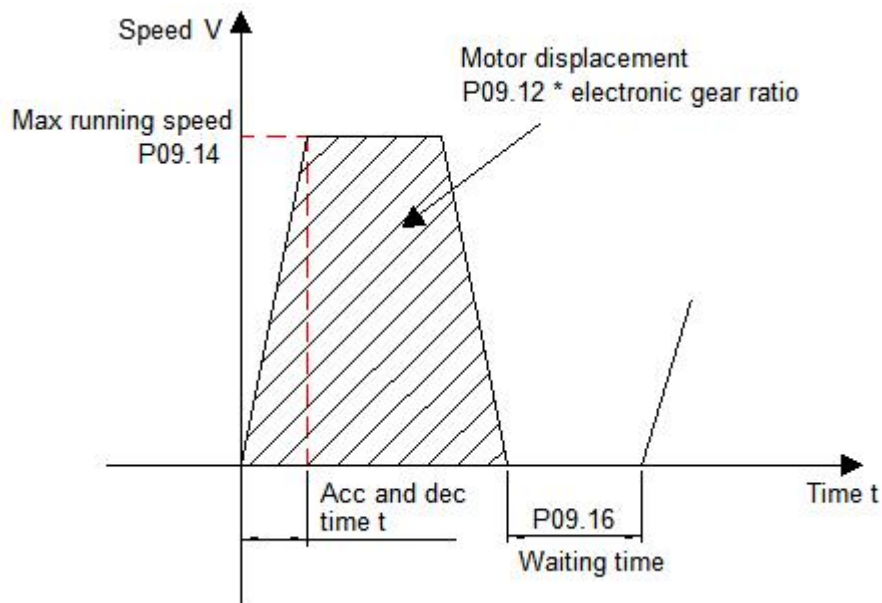

Therefore, the actual acceleration time t to P09.14 (Maximum running speed of segment 1 displacement):

$$t = \frac{P09.14}{1000} \times P09.15$$

For the setting of the remaining 15 parameters, please refer to the parameter descriptions in [Chapter 7](#).

(3) Multi-segment position command enable

When selecting multi-segment position command as the source of position command, please configure 1 IN terminal of the servo drive as function 21 (FunIN.21: multi-segment position command enable), and confirm the valid logic of IN terminal.

★ Associated parameter description

Coding	Name	Function name	Function
FunIN.21	PosInSen	Multi-segment position command enable	Valid: motor runs multi-segment position command Invalid: the motor is in a locked state Note: When P09.00=0/1, the logic of IN terminal corresponding to FunInSen signal is valid for level When P09.00=2, the logic of IN terminal corresponding to FunInSen signal is valid along the change

4. The source of position command is communication control (P03.00=3)

Under this position command source, the start and stop of the motor can be controlled through communication, and the corresponding parameters can also be set to make the motor work in continuous running in one direction/reciprocating direction (demonstration running mode) for debugging or aging testing.

★ Associated parameter description

Parameter	Name	Range	Unit	Function	Setting method	Effective time	Default
P04.60 P04.61	Communication command pulse	0~ 1073741824	Command unit	Set command pulse for communication running	Set when running	Next run	50000
P04.62	Communication speed	0~6000	rpm	Set the maximum speed for communication running	Set when running	Next run	1000
P04.63	Communication acceleration time constant	1~65535	ms	Set the time for the motor speed to accelerate uniformly from 0rpm to 1000rpm	Set when running	Next run	200
P04.64	Communication deceleration time constant	1~65535	ms	Set the time for the motor speed to decelerate uniformly from 1000rpm to 0rpm	Set when running	Next run	200
P04.65	Internal demo running mode	0~1	-	Set the running mode of internal demo running 0: Motor reciprocating 1: Motor runs in one direction	Set when running	Next run	0
P04.66	Internal demo start running direction	0~1	-	Set the starting direction of the internal demo running 0: positive direction 1: negative direction	Set when running	Next run	0
P04.67	Number of internal demo running	0~65535	-	Set the number of internal demo running	Set when running	Next run	Next run
P12.09	Communication displacement mode	0~1	-	Set the type of position command for communication running: 0: Incremental position mode	Set when running	Next run	Next run

				1: Absolute position mode			
P12.10	Communication start/stop command	0~6	-	Start/stop command for drive communication running	Set when running	Effective immediately	6
P12.12	Internal demo waiting time	0~65535	ms	Set the waiting time for internal demo running	Set when running	Next run	200
P12.13	Internal demo start/stop command	0~2	-	Start/stop command for internal demo running of the drive	Set when running	Effective immediately	0
P01.33	Emergency stop deceleration time constant	1~65535	ms	When setting the emergency stop, the motor speed uniformly decelerates from 1000rpm to 0rpm	Set when running	Effective immediately	30

The startup method is as follows:

(1) The motor works in communication control mode

Write the start and stop commands of operation through P12.10, and the motor will run according to the running curve determined by the command stroke, speed, acceleration and deceleration time constant set in P04.60~P04.64.

Value written in P12.10	Description
0	Write: trigger the motor to decelerate to stop. After the motor responds to the start-stop command, set P12.10 to 6.
1	Write: Trigger the motor to run forward of the command set by P04.60 and stop. After the motor responds to the start-stop command, set P12.10 to 6.
2	Write: Trigger the motor to run reversely of the command set by P04.60 and stop. After the motor responds to the start-stop command, set P12.10 to 6.
3	Write: Trigger the motor to jog forward. After the motor responds to the start-stop command, set P12.10 to 6.
4	Write: Trigger the motor to jog reverse. After the motor responds to the start-stop command, set P12.10 to 6.
5	Write: trigger the emergency stop of the motor. After the motor responds to the start-stop command, set P12.10 to 6.
6	Write: meaningless; Read: indicates that the motor is running or waiting to be triggered to run.

(2) The motor works in cyclic operation (demonstration) mode

write the start and stop commands of the demonstration through P12.13. In the demo running mode, the motor will start in reciprocating or single direction (P04.65=0/1) according to the running command, speed, acceleration and deceleration time constant set by P04.60~P04.64, and start in positive or negative direction (P04.66=0/1), run the number of times set by P04.67. After completing the set running command each time and setting the delay time by P12.12, restart again and run in this cycle.

Value written in P12.13	Description
0	Write: stop the operation of the demo mode; Read: indicates that the motor is waiting to be triggered to run.
1	Write: start the operation of the demo mode; set P12.13 to 2 after the motor responds to the start-stop command.
2	Write: meaningless; Read: indicates that the motor is working in demo mode.

5. The source of position command is communication trigger control (P03.00=4)

Under this position command source, the relative stroke or absolute position parameter P03.58 of the operation can be written through communication (P03.57 is displayed on the LED display panel of the driver, and the position command stroke is composed of the two registers P03.57/P03.58 to form a signed 32-bit integer value, where P03.57 is the low 16-bit value, and P03.58 is the high 16-bit value. The trigger mode of communication control is to write the value of P03.58 (high 16 bits) by communication to start running, when the motor is running, the upper computer can dynamically modify the stroke, speed, acceleration and deceleration through communication, and the driver responds to the operating parameters immediately.

★ Associated parameter description

Parameter	Name	Range	Unit	Function	Setting method	Effective time	Default
P03.53	Running position mode	0~1	-	Set the position mode of drive running 0: Incremental position mode 1: Absolute position mode	Set after stopping	Effective immediately	0
P03.54	Communication control acceleration	1~65535	ms	Set the time to accelerate uniformly from 0rpm to 1000rpm	Set when running	Effective immediately	100
P03.55	Communication control deceleration	1~65535	ms	Set the time to decelerate uniformly from 1000rpm to 0rpm	Set when running	Effective immediately	100

P03.56	Communication control speed	0~6000	rpm	Set the speed of communication control running	Set when running	Effective immediately	500
P03.57 P03.58	Communication control position	-10737 41824 ~ 10737 41824	Command unit	Set the stroke/position of communication control running, Pn229 is the high 16 bits, and Pn228 is the low 16 bits. Communication writing to Pn229 will immediately trigger a run (when the motor is stopped) or dynamically modify the running position (when the motor is running)	Set when running	Effective immediately	10000

- ◆ Write the high 16-bit register (P03.58) of the stroke/position through the host computer communication to realize the start of the motor.
- ◆ In the incremental position mode, when the motor is running and the reverse running stroke (P03.57/P03.58) is triggered by communication, the motor will run the user-set reverse stroke with the stop position as the starting point after decelerating and stopping according to the set deceleration time constants.

6. The source of position command is fixed-length/jog control (P03.00=5)

When the position command source is set to fixed-length/jog control, it has the following functions:

- ◆ Control motor fixed-length forward and reverse through external input terminals
- ◆ Control motor jog forward and reverse through external input terminals
- ◆ Control motor jogging through external input terminals: start-stop + direction mode

(1) Control motor fixed-length forward and reverse through external input terminals

★ Associated parameter description

Parameter	Name	Range	Unit	Function	Setting method	Effective time	Default
P04.20	Point-to-point speed	0~6000	rpm	Set the maximum running speed	Set when running	Next run	200
P04.22	Point-to-point acceleration	1~65535	ms	Set the time for the motor speed to uniformly accelerate from 0rpm to 1000rpm	Set when running	Next run	100

P04.23	Point-to-point deceleration	1~65535	ms	Set the time for the motor speed to uniformly decelerate from 1000rpm to 0rpm	Set when running	Next run	100
P04.24 P04.25	Point-to-point stroke	-1073741824 ~ 1073741824	Command unit	Set the stroke/position of the motor running at a fixed-length	Set when running	Next run	10000
P01.33	Emergency stop deceleration time constant	1~65535	ms	When setting the emergency stop, the motor speed uniformly decelerates from 1000rpm to 0rpm	Set when running	Effective immediately	30

The startup mode is as follows:

Set the corresponding IN terminal function to "FunIN.27: USER4 (fixed-length forward)", "FunIN.28: USER5 (fixed-length reverse)" of [group P02: terminal input/output parameters](#), use external input to trigger the start. It should be note that the trigger signal is an edge signal. Triggering the start again while the motor is running will not work. Similarly, if the trigger signal remains valid, the motor will still not respond to other operating modes in the command source after it stops.

(2) Control motor jog forward and reverse through external input terminals

★ Associated parameter description

Parameter	Name	Range	Unit	Function	Setting method	Effective time	Default
P04.20	Jog forward speed	0~6000	rpm	Set the maximum running speed	Set when running	Next run	200
P04.21	Jog reverse speed	0~6000	rpm	Set the maximum running speed	Set when running	Next run	200
P04.22	Jog deceleration	1~65535	ms	Set the time for the motor speed to uniformly accelerate from 0rpm to 1000rpm	Set when running	Next run	100
P04.23	Jog deceleration	1~65535	ms	Set the time for the motor speed to uniformly decelerate from 1000rpm to 0rpm	Set when running	Next run	100
P01.33	Emergency stop deceleration time constant	1~65535	ms	When setting the emergency stop, the motor speed uniformly decelerates from 1000rpm to 0rpm	Set when running	Effective immediately	30

The startup mode is as follows:

Set the corresponding IN terminal function to "FunIN.25: USER2 (jogging forward)", "FunIN.26: USER3 (jogging reverse)" of [group P02: terminal input/output parameters](#), use external input to trigger the start (the trigger signal is level effective).

(3) Control motor jogging through external input terminals: start-stop + direction

★ Associated parameter description

Parameter	Name	Range	Unit	Function	Setting method	Effective time	Default
P04.20	Jog forward speed	0~6000	rpm	Set the maximum running speed	Set when running	Next run	200
P04.21	Jog reverse speed	0~6000	rpm	Set the maximum running speed	Set when running	Next run	200
P04.22	Jog deceleration	1~65535	ms	Set the time for the motor speed to uniformly accelerate from 0rpm to 1000rpm	Set when running	Next run	100
P04.23	Jog deceleration	1~65535	ms	Set the time for the motor speed to uniformly decelerate from 1000rpm to 0rpm	Set when running	Next run	100
P01.33	Emergency stop deceleration time constant	1~65535	ms	When setting the emergency stop, the motor speed uniformly decelerates from 1000rpm to 0rpm	Set when running	Effective immediately	30

The startup mode is as follows:

Set the corresponding IN terminal function as "FunIN.24: USER1 (jogging start and stop)", "FunIN.18: torque command direction setting (jogging direction)" of [group P02: terminal input/output parameters](#), Use the external input to trigger the start and stop of the motor and control the direction of the motor (the trigger signal is level effective).

6.1.2. Electronic Gear Ratio

1. Electronic gear ratio concept

In the position control mode, the input position command (command unit) is to set the load displacement, and the motor position command (encoder unit) is to set the motor displacement, in order to establish the proportional relationship between the motor position command and the input position command, the electronic gear ratio function is introduced.

Through the frequency division (electronic gear ratio<1) or frequency multiplication (electronic gear ratio>1) function of the electronic gear ratio, the actual displacement of the motor rotation or movement can be set when the input position command is 1 command unit.

★ Term explanation

Command unit: Refers to the minimum recognizable value input from the upper device to the drive.

Encoder unit: Refers to the value of the input command after processing the electronic gear ratio.

2. Setting steps of electronic gear ratio

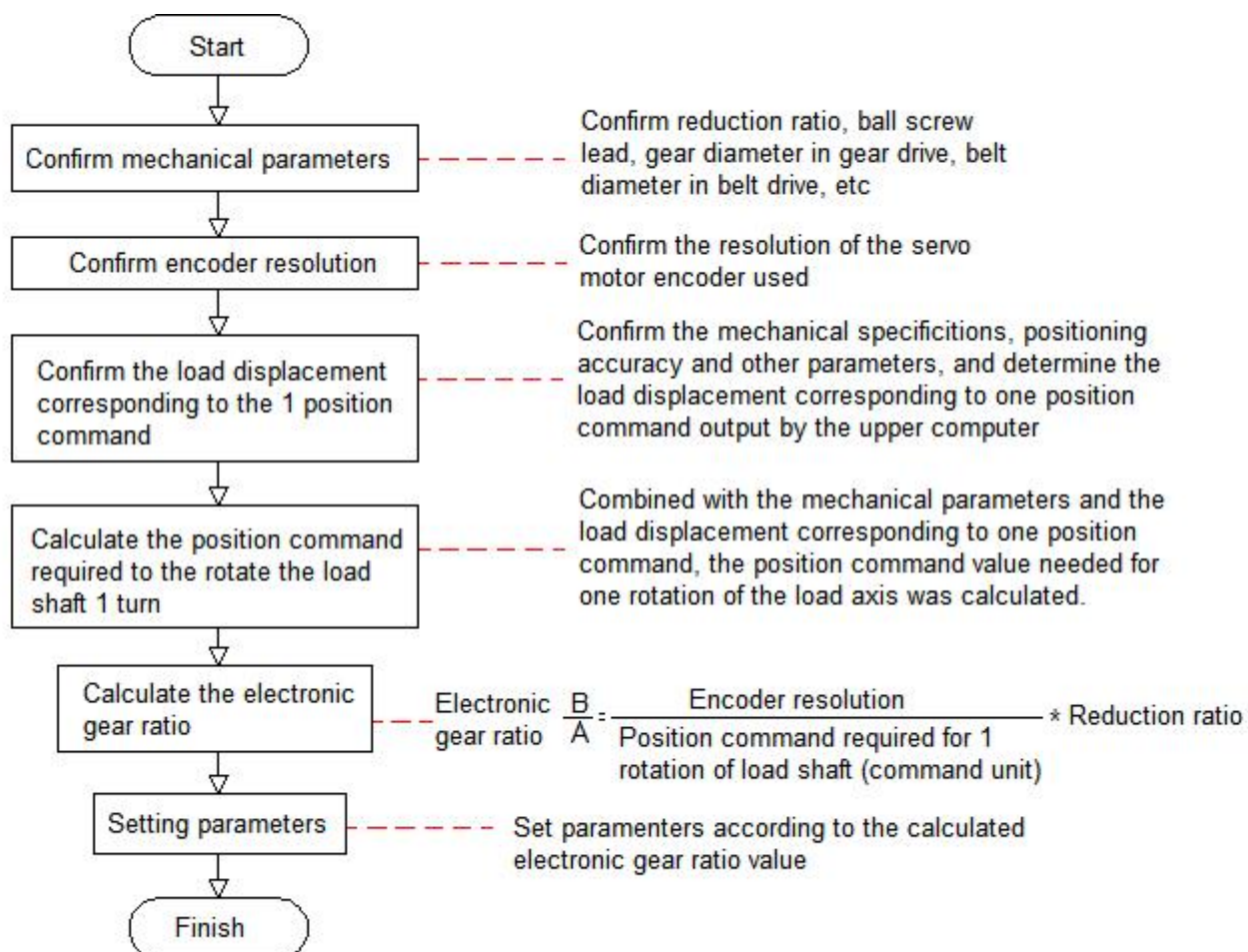

★ Associated parameter description

Parameter	Name	Range	Unit	Function	Setting method	Effective time	Default
P03.06 P03.07	Number of position commands for motor rotation	0~8388608	p/r	Set the number of position commands required for one rotation of motor	Set after stopping	Effective immediately	10000
P03.08 P03.09	Electronic gear ratio 1 numerator	1~ 1073741824	-	Set the numerator of electronic gear ratio 1 ● Effective when P03.06/P03.07 is set to 0	Set after stopping	Effective immediately	1

P03.10 P03.11	Electronic gear ratio 1 denominator	1~ 1073741824	-	Set the denominator of electronic gear ratio 1 ● Effective when P03.06/P03.07 is set to 0	Set after stopping	Effective immediately	1
P03.12 P03.13	Electronic gear ratio 2 numerator	1~ 1073741824	-	Set the numerator of electronic gear ratio 2 ● Effective when P03.06/P03.07 is set to 0	Set after stopping	Effective immediately	1
P03.14 P03.15	Electronic gear ratio 2 denominator	1~ 1073741824	-	Set the denominator of electronic gear ratio 2 ● Effective when P03.06/P03.07 is set to 0	Set after stopping	Effective immediately	1

- ◆ Note: When P03.06 (number of position commands for one motor rotation) is set to other than 0, the electronic gear ratio: $A/B = \text{Encoder resolution}/P03.06$, at this time, electronic gear ratio 1 (P03.08/P03.10) and electronic gear ratio 2 (P03.12/P03.14) are invalid.

6.1.3. Position Command Filtering

Position command filtering is to filter the position command (encoder unit) after the electronic gear ratio frequency division or frequency multiplication. The methods are average filtering and first-order low-pass filtering.

In the following applications, you should consider adding position command filtering:

- ◆ The position command output by the host computer has not been processed for acceleration and deceleration
- ◆ Low pulse command frequency
- ◆ When the electronic gear ratio is more than 10 times

★ Associated parameter description

Parameter	Name	Range	Unit	Function	Setting method	Effective time	Default
P03.04	Position command average filter time constant	1~2048	0.1ms	Set the time constant for the average value filter of the position command (encoder unit)	Set after stopping	Effective immediately	1
P03.05	Position command first-order low-pass filter time constant	0~65535	0.1ms	Set the first-order low-pass filter time constant of position command	Set after stopping	Effective immediately	0

Remark:

- ◆ This function has no effect on the displacement (total number of position commands).
- ◆ If the set value is too large, the response delay will increase. The filter time constant should be set according to the actual situation.

6.1.4.Signal Positioning Complete Signal

The positioning completion function means that when the drive detects that the position error is less than P03.22 (P03.22: positioning completion threshold, the unit is set by P03.21: the unit of in-position completion threshold), and it outputs the in-position completion signal when it is maintained for a certain period of time (P03.20: In-position completion window time).

★ Associated parameter description

Parameter	Name	Range	Unit	Function	Setting method	Effective time	Default
P03.20	In-position completion window time	0~65535	1ms	Set the delay time for the output of the in-position completion signal of the motor	Set when running	Effective immediately	10
P03.21	Unit of in-position completion threshold	0~1	-	Set the unit of in-position completion threshold P03.22 0: Pulse unit 1: Encoder unit The default value is different under each drive model, the default value is 0 under EtherCAT/CANopen, and the default value is 1 under pulse model)	Set when running	Effective immediately	1
P03.22	Positioning completion threshold	1~65535	Encoder unit	Set the positioning accuracy when the motor in-position signal is output	Set when running	Effective immediately	10

6.1.5.Homing Function

1. Function introduction

- ◆ **Origin/Mechanical origin:** The origin is also called mechanical origin, which can be expressed as the origin switch signal or limit switch signal, and is set by Parameter P03.41 (Homing mode selection).
- ◆ **Zero point:** The positioning target point, which can be expressed as origin + offset (P03.46/P03.47: mechanical origin offset). When the offset is set to 0, the zero point coincides with the origin.
- ◆ **Homing function:** The homing function is a function that the motor will actively find the zero point and complete the positioning after triggering the homing function when the drive is enabled. During the operation of homing, other position commands (including the re-triggered homing enable signal) are shielded; After the homing operation is completed, the drive can respond to other position commands. The homing function includes two modes: origin homing and electrical homing.
- ◆ **Origin homing:** After the drive receives the homing trigger signal, the drive will actively position the relative position between the motor shaft and the mechanical origin according to the preset mechanical origin. First find the origin, and then move the offset to the zero point position based on the origin. The origin homing is usually used to find the zero point for the first time.
- ◆ **Electrical homing:** After the zero point position is determined by the origin homing operation, take the current position as the starting point and move a relative displacement.

After the homing is completed (including the origin homing and electrical homing), the current position of the motor (P13.07/P13.08: position command counter) is consistent with the mechanical origin offset (P03.46/P03.47: mechanical origin offset). After the homing is completed, the drive outputs the origin homing completion signal, and the upper computer can confirm that the homing is completed after receiving the signal.

2. Origin homing

The following cases are used as examples to illustrate the operation mode of origin homing.

- ◆ Forward return to origin: deceleration point, origin as origin switch (P03.41 = 0)
- ◆ Forward return to origin: deceleration point, origin as forward limit switch (P03.41=2)
- ◆ Forward return to origin: deceleration point, origin as mechanical limit position (P03.41=4)

(1) Forward return to origin: deceleration point, origin as origin switch (P03.41 = 0)

- 1) **The origin switch (decelerate point) signal is invalid (0 - invalid, 1 - valid) before the motor returns to origin, and the positive limit switch is not triggered in the whole process.**

The motor first searches for the deceleration point signal in the forward direction at the set value of P03.42 (High speed search origin switch signal speed) until it encounters the rising edge of the deceleration point. After decelerating to 0 according to the deceleration time constant set in P03.44 (Search for the acceleration and deceleration time constant of the zero switch signal), it reverses the acceleration to the set value of -P03.43 (Low speed search origin switch signal) and searches for the

deceleration point signal falling edge at low speed. When it encounters the falling edge of the deceleration point signal, it will decelerate and stop, and then continue to search for the rising edge of the deceleration point in the low speed forward direction with the set value of P03.43. During forward acceleration or forward uniform speed operation, the machine will stop immediately when it encounters the rising edge signal of the origin signal.

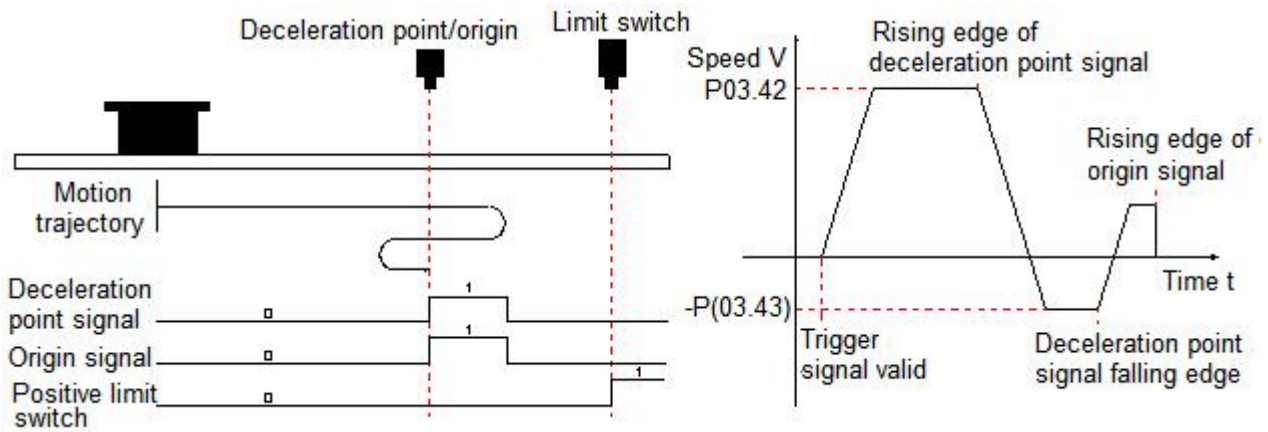

2) The origin switch (decelerate point) signal is valid (0 - invalid, 1 - valid) before the motor returns to origin, and the positive limit switch is not triggered in the whole process.

The motor directly searches for the falling edge of the deceleration point signal in the reverse direction at the set value of -P03.43 (Low speed search origin switch signal speed), and decelerates to stop when it encounters the falling edge of the deceleration point signal, and then continues to search for the rising edge of the deceleration point signal in the forward direction with the set value of P03.43, and stops immediately when it encounters the rising edge of the origin signal in the forward direction of acceleration or uniform speed operation.

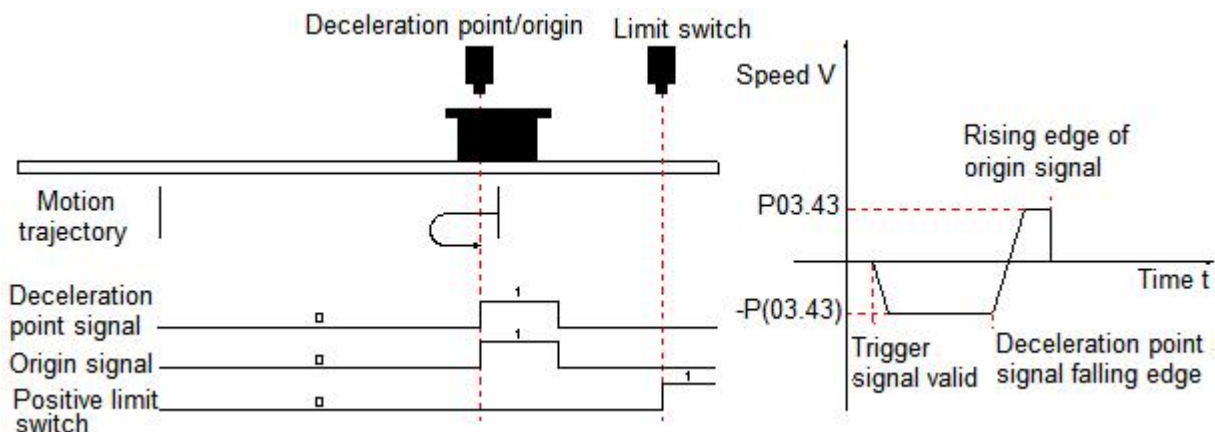

3) The origin switch (decelerate point) signal is invalid (0 - invalid, 1 - valid) before the motor returns to origin, and the positive limit switch is triggered during the process of returning to origin.

The motor first searches for the deceleration point signal in the forward direction with the set value of P03.42 (High speed search origin switch signal speed), and stops after encountering the positive limit switch and decelerating to 0 according to the deceleration time constant set in P01.33 (Emergency stop deceleration time constant). And in accordance with P03.49 (Mechanical origin offset and limit processing method), immediately return to the origin in reverse direction (P03.49=2/3), or stop and wait for the upper device to give the trigger signal to return to origin again (P03.49=0/1). After the conditions are met, the motor searches for the falling edge of the deceleration point signal in the reverse direction with the set value of -P03.42. After encountering the deceleration point signal falling edge, decelerate the speed to 0 in accordance with the deceleration time set by P03.44 (Search for the acceleration and deceleration time constant of the zero switch signal), and then forward accelerate to the set value of P03.43 (Low speed search origin switch signal speed), and forward accelerate or forward uniformly in operation, and stop immediately when encountering the signal of the rising edge of the origin signal.

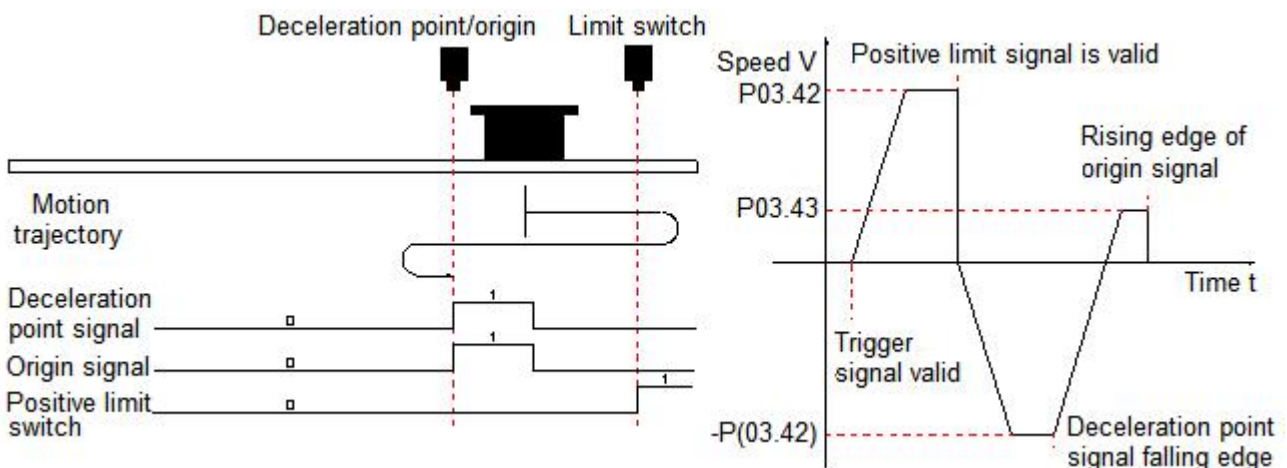

(2) Forward return to origin: deceleration point, origin as forward limit switch (P03.41=2)

1) Positive limit switch (deceleration point) signal is invalid (0 - invalid, 1 - valid) before the motor returns to origin.

The motor first searches for the deceleration point signal in the forward direction at the value set in P03.42 (High speed search origin switch signal speed) until it encounters the rising edge of the deceleration point. After decelerating to 0 according to the deceleration time set in P03.44 (Search for the acceleration and deceleration time constant of the zero switch signal), the motor accelerates in the reverse direction to the value set in -P03.43 (Low speed search origin switch signal speed) and searches for the deceleration point signal falling edge at low speed. When it encounters the falling edge of the deceleration point signal, it will decelerate to stop, and then continue to search for the rising edge of the deceleration point in the low speed forward direction with the set value of P03.43. During forward

acceleration or forward uniform speed operation, will stop immediately when it encounters the rising edge signal of the positive limit switch signal.

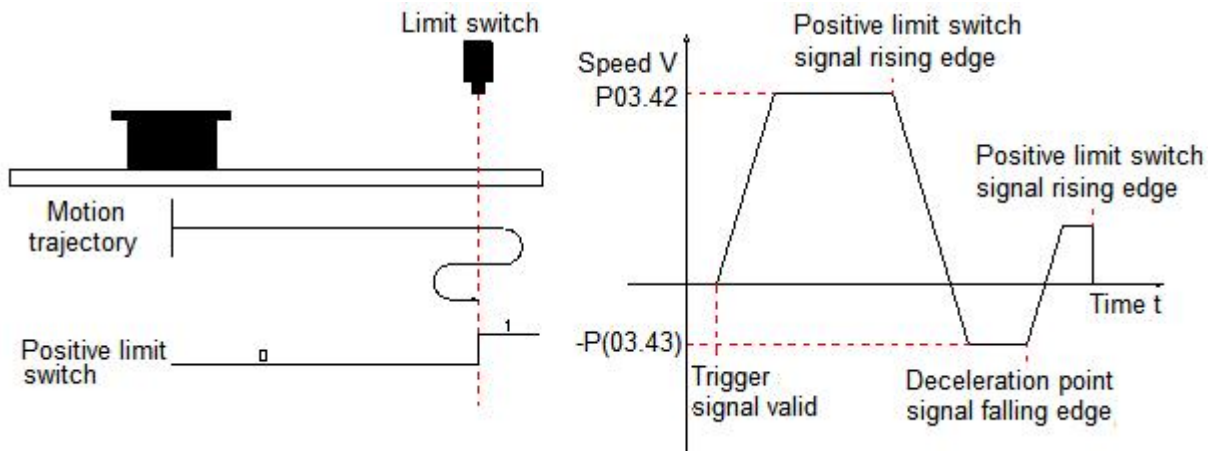

2) Positive limit switch (deceleration point) signal is valid (0 - invalid, 1 - valid) before the motor returns to origin.

The motor directly searches for the falling edge of the deceleration point signal in the reverse direction at the set value of -P03.43 (Low speed search origin switch signal speed), and immediately decelerates to stop when it encounters the falling edge of the deceleration point signal, and then continues to search for the rising edge of the deceleration point signal in the forward direction with the set value of P03.43, and stops immediately when it encounters the rising edge of the forward limit switch signal during positive acceleration or uniform speed operation.

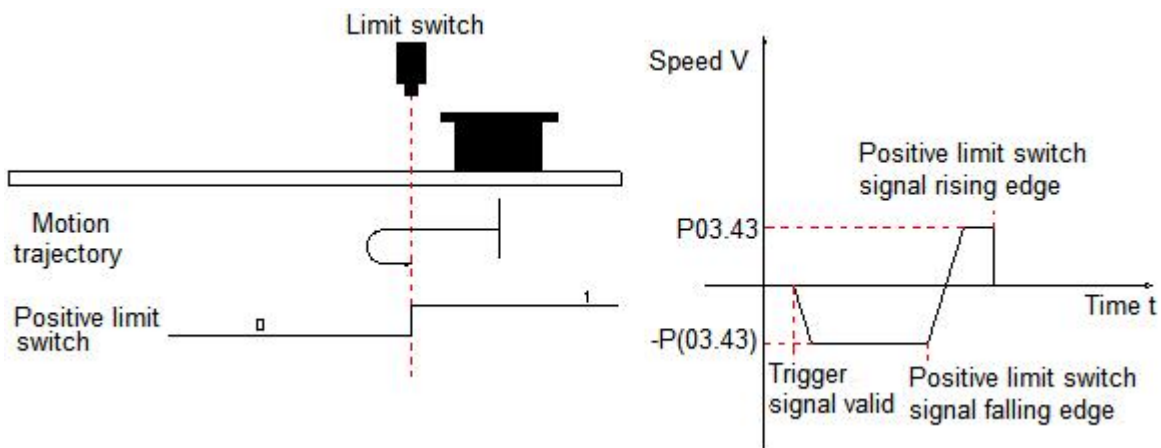

(3) Forward return to origin: deceleration point, origin as mechanical limit position (P03.41=4)

The motor first runs at low speed in the positive direction with the set value of P03.43 (Low speed search origin switch signal speed), and after collision to the mechanical limit position, if the motor torque reaches P03.52 (Touch stop homing torque limit) and the actual motor speed is lower than P03.51 (Touch stop homing speed judgment threshold), and this state is maintained for a certain time P03.50 (Touch stop homing time judgment threshold), it is judged that the motor runs to the mechanical limit position and stops immediately.

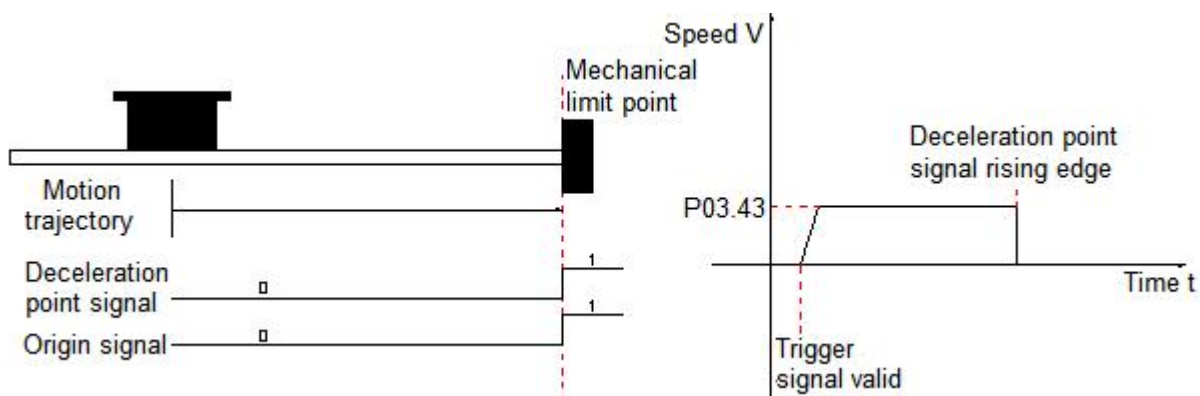

1) Electrical homing

The mechanical zero point of the system is known after the motor has undergone a mechanical homing operation. At this time, after setting P03.46/P03.47, the motor can be moved from the current position (P13.07/P13.08) to the specified position (P03.46/P03.47). In the electrical homing mode, the motor runs at high speed at the set value of P03.42 (High speed search origin switch signal speed) throughout the entire process, and the total motor displacement is determined by the difference between P13.07/P13.08 and P03.46/P03.47, and the running direction is determined by the positive or negative of the total motor displacement. After the displacement command is completed, the motor will stop.

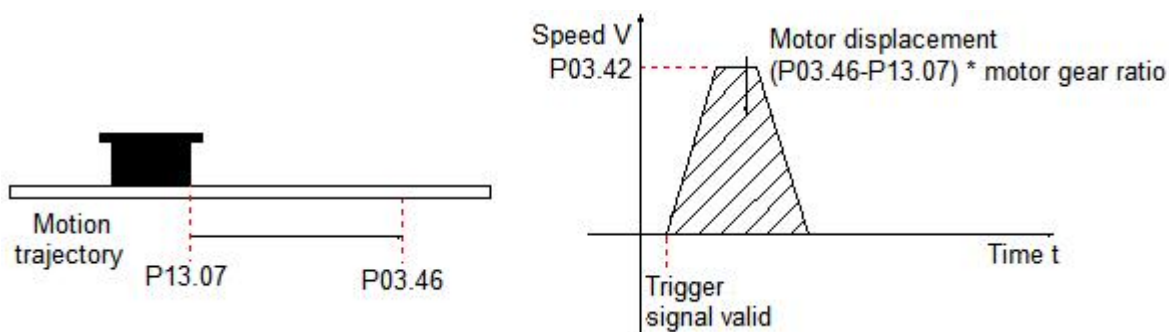

2) Mechanical origin and mechanical zero point

Take P03.41=0 as an example to illustrate the difference between mechanical origin and mechanical zero point:

The mechanical origin does not coincide with the mechanical zero point	The mechanical origin coincides with the mechanical zero point
<p>If the origin offset (P03.46/P03.47) is set and the mechanical origin does not coincide with the mechanical zero point (P03.49=0/2), during forward acceleration or forward uniform operation, the motor stops immediately after encountering the rising edge of the origin signal. And the current position of the motor P13.07/P13.08 is forced to the set value of P03.46/P03.47 after stopping.</p>	<p>If the origin offset (P03.46/P03.47) is set and the mechanical origin coincides with the mechanical zero point (P03.49=1/3), the motor stops immediately after encountering the rising edge of the origin signal during forward acceleration or forward uniform speed operation. After that, the motor stops after running the stroke of the set value P03.46/P03.47. At this time, the current position of the motor P13.07/P13.08 and the set value of P03.46/P03.47 are the same.</p>

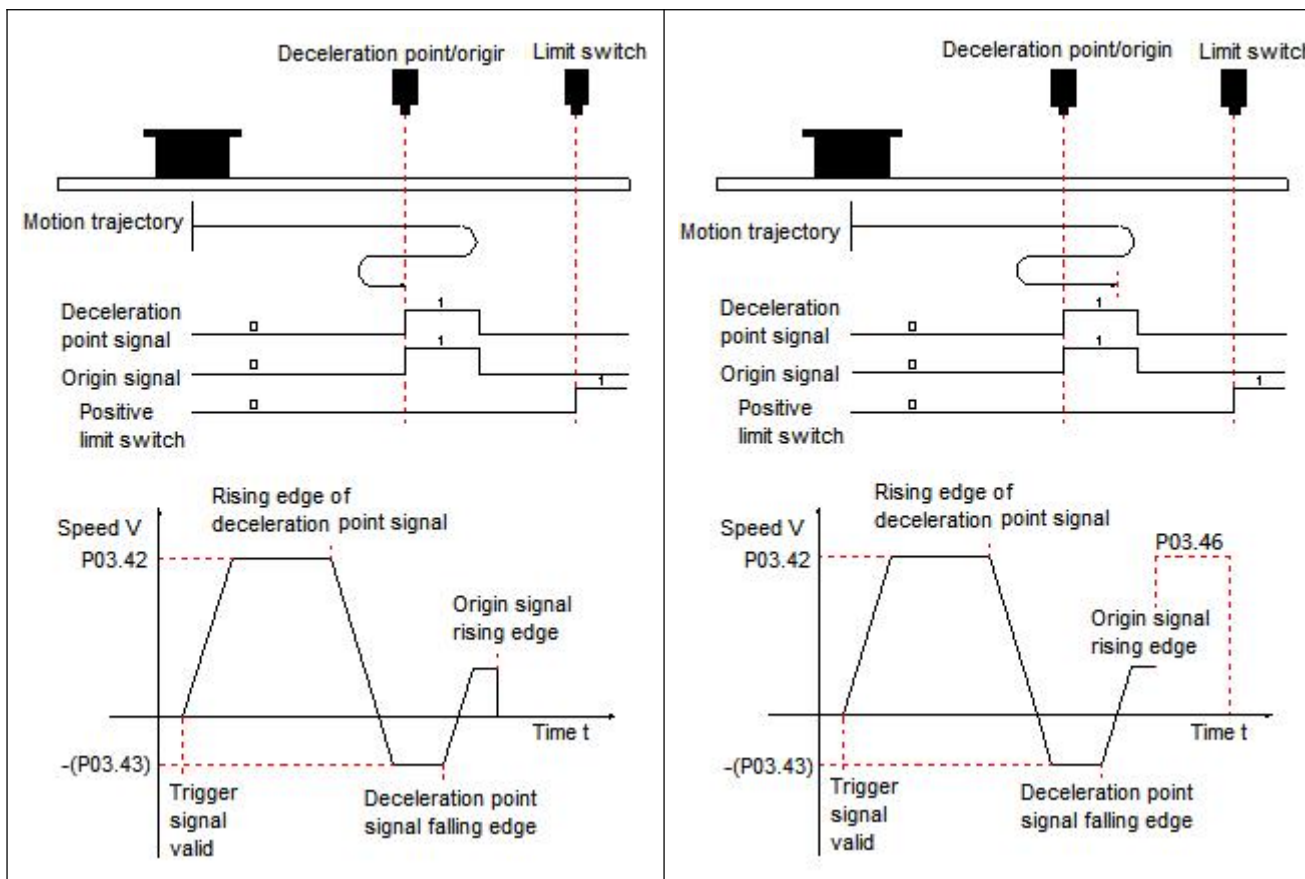

6.1.6. Interrupt Fixed-length Function

The function of interrupting the fixed-length means that in the position control mode, the current running state of the servo is interrupted and the preset fixed-length command is executed. That is, after the interrupt fixed-length function is triggered, the servo motor will run the position command set by the interrupted fixed-length function according to the motor rotation direction before the trigger.

◆ Note: The interrupt Function does not take effect during the internal homing operation

★ Associated parameter description

Parameter	Name	Range	Unit	Function	Setting method	Effective time	Default
P03.33	Interrupt fixed-length enable	0~1	-	Set whether to enable interrupt fixed-length function 0: Prohibited 1: Enable	Set after stopping	Power off and restart	0
P03.34 P03.35	Interrupt fixed-length displacement	0~10737418 24	Command unit	Set interrupt fixed-length displacement	Set when running	Effective immediately	10000
P03.36	Interrupt fixed-length	0~6000	rpm	Set the maximum speed of the motor during	Set when	Effective immediately	100

	maximum speed			interrupt fixed-length operation	running		
P03.37	Interrupt fixed-length acceleration and deceleration	1~65535	ms	Set the time for the motor speed to change uniformly from 0rpm to 1000rpm	Set when running	Effective immediately	100
P03.38	Interrupt fixed-length lock contact signal enable	0~1	-	Set the conditions for responding to other position commands after the interrupt fixed-length operation is completed. When the set value is 1, INFunctionFunIN.30 (interrupt fixed-length state release signal) must be used to contact the locked state	Set when running	Effective immediately	1

★ Associated input and output description

Coding	Name	Function
FunIN.30	Interrupt fixed-length state release	Valid: release the interrupt fixed-length lock state, and the servo drive can respond to other position commands. Invalid: keep the interrupt fixed-length lock state, and the servo drive does not respond to other position commands.
FunIN.31	Interrupt fixed-length prohibition	Valid: prohibit the interrupt fixed-length function. Invalid: allow the interrupt fixed-length function.
FunOUT.16	Interrupt fixed-length completion signal	Valid: in position control, the interrupt fixed-length displacement operation is completed. Invalid: in position control, the interrupt fixed-length displacement operation is not completed.

6.2. Speed Control Mode

Set the value of parameter P01.00 to 1, to enable the drive to work in speed control mode.

6.2.1. Speed Command Input Setting

In speed control mode, the source of speed command should be set by parameter P04.00 first.

★ Associated parameter description

Parameter	Name	Range	Function	Setting method	Effective time	Default
P04.00	Speed command source selection	0: Digital given 1: Multi-segment speed command 2: Communication control 3: IO control 4: Analog control (reserved) 5~10: Reserved	Set the source of speed commands in speed control mode	Set after stopping	Effective immediately	0

1. Speed command source is digital given (P04.00=0)

★ Associated parameter description

Parameter	Name	Range	Unit	Function	Setting method	Effective time	Default
P04.01	Speed command digital given value	-6000 ~6000	rpm	Set the maximum speed of motor running Speed is a signed value, a positive number means positive rotation, a negative number means reverse rotation	Set when running	Effective immediately	1000
P04.05	Speed command acceleration time constant	1~ 65535	ms	Set the time for the motor speed to uniformly accelerate from 0rpm to 1000rpm	Set when running	Effective immediately	200
P04.06	Speed command deceleration time constant	1~ 65535	ms	Set the time for the motor speed to decelerate uniformly from 1000rpm to 0rpm	Set when running	Effective immediately	200
P01.33	Emergency stop deceleration time constant	1~ 65535	ms	Set the time for the motor speed to uniformly decelerate from 1000rpm to 0rpm during emergency stop	Set when running	Effective immediately	30

The startup method is as follows:

The motor starts to run when the servo is enabled, that is, the drive start and stop are controlled by the drive enable signal.

- ◆ The motor can modify the running speed through communication during running, and it will take effect immediately.
- ◆ When the motor encounters a limit or emergency stop input, it will decelerate to stop according to the emergency stop deceleration time constant set by P01.33. And after stopping, even if the limit or

emergency stop input signal becomes invalid, the motor will not start to run, and it must be re-enabled to trigger the running of the motor.

- ◆ The motor can select the running direction by setting the input terminal function to "FunIN.19 (speed command direction setting)". The actual running direction of the motor is as follows:

P01.01 (Rotation direction selection)	P04.01 (Speed command digital given value)	Speed command direction setting	Actual running speed of motor
0	+	Invalid	CCW
	+	Valid	CW
	-	Invalid	CW
	-	Valid	CCW
1	+	Invalid	CW
	+	Valid	CCW
	-	Invalid	CCW
	-	Valid	CW

2. Speed command source is multi-segment speed command (P04.00=1)

The servo drive has the function of multi-segment speed running. It means that there are 16 speed commands stored inside the servo drive, and the maximum running speed and running time of each segment can be set separately. And equipped with 7 groups of acceleration and deceleration time for selection. The setting process is as follows:

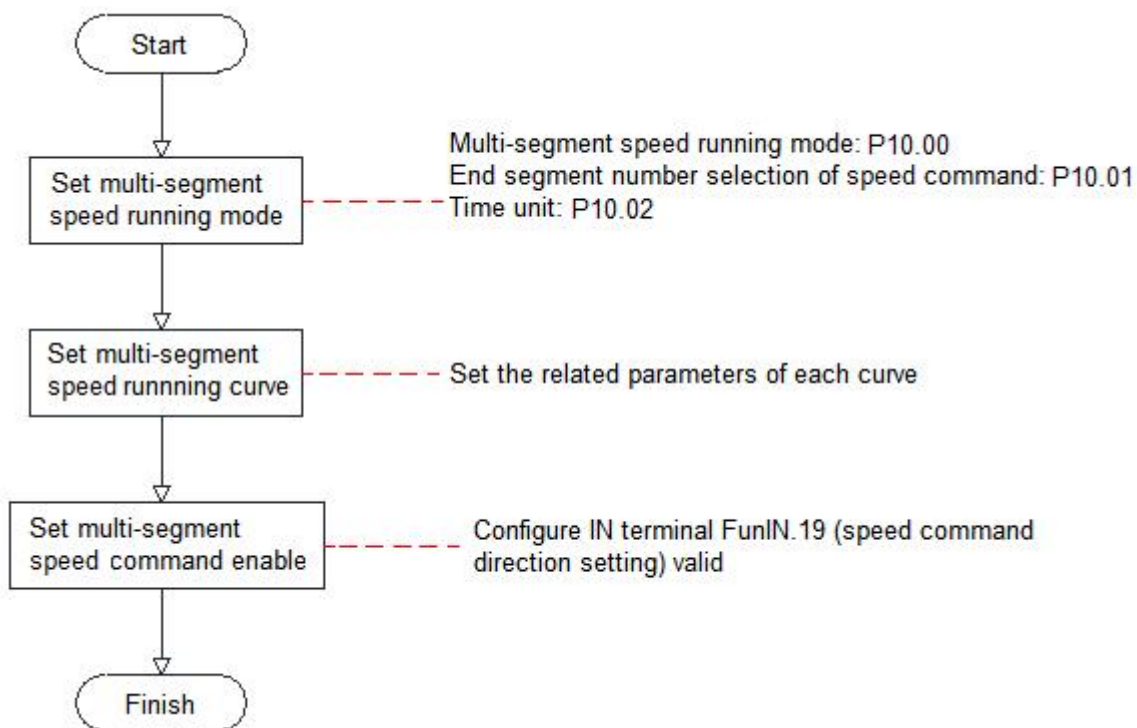

(1) Set multi-segment speed running mode

★ Associated parameter description

Parameter	Name	Range	Function	Setting method	Effective time	Default
P10.00	Multi-segment speed command running mode	0: stop at the end of a single operation 1: Cycle operation 2: Switch through the external IN pot	Set multi-speed command running mode	Set when running	Next run	1
P10.01	Number of speed command end segments	1~16	Set the number of segments required for a multi-step speed command	Set when running	Next run	16
P10.02	Running time unit	0: ms 1: s	Select the unit of multi-segment speed command running time	Set when running	Next run	0

The external IN terminal can be configured with the function FunIN.19 (speed command direction setting) for multi-segment operation command direction selection.

Coding	Function name	Function
FunIN.19	Speed command direction setting	Invalid: default command direction Valid: the opposite direction of the command

Take P10.01=2 as an example to illustrate each mode:

1) Stop at the end of a single operation (P10.00=0)

P10.00 is set to 0 and the single run end stop mode is selected. After setting parameters P10.01 and P10.02 respectively according to the total number of executed segments and execution time units, and setting parameters such as command value, running time and acceleration/deceleration time of the corresponding segment according to the demand, the drive will run from segment 1 to segment N according to the segment code until it stops after running the last segment.

Mode description	Running curve
<ul style="list-style-type: none"> Run 1 round The segment number is automatically incremented and switched 	

	<p>V1max、V2max: Command speed of the 1st and 2nd segment.</p> <p>t1: The actual acceleration and deceleration time of the first segment.</p> <p>t3、t5: The actual acceleration and deceleration time of the second segment.</p> <ul style="list-style-type: none"> ● A certain period of running time: the shifting time of the previous speed command switching to this speed command + the constant speed running time of this segment(for example: the running time of the first segment in the figure is t1+t2, and the running time of the second segment is t3+t4. And so on) ● When a certain period of running time is set to 0, the drive will skip this segment speed command and execute the next segment.
--	---

★ Term explanation

The total number of multi-segment speed commands set by P10.01 when the drive completes one run is called the completion of one round of operation.

2) Cycle operation (P10.00=1)

P10.00 is set to 1, and the cycle operation mode is selected. After setting the Parameters P10.01 and P10.02 respectively according to the total number of execution segments and execution time unit, and setting the command value, running time, acceleration/deceleration time and other parameters of the corresponding segment according to the demand, the module will run according to the setting of the command running time and acceleration/deceleration time of each segment, and the drive will run in the mode of speed segment from the first segment to the Nth segment, and automatically jump to the first segment for cycle operation after the last segment.

Mode description	Running curve
<ul style="list-style-type: none"> ● Cycle operation, the starting segment number of each round is 1 ● The segment number is automatically incremented and switched ● If the servo enable is valid, the cycle running state will always be maintained 	<p>V1max、V2max: Command speed of the 1st and 2nd segment</p> <ul style="list-style-type: none"> ● A certain period of running time: the shifting time of the previous speed command switching to this speed command + the constant speed running time of this segment(for example: the running time of the first segment in the figure is t1+t2, and the running time of the second segment is t3+t4. And so on) ● When a certain period of running time is set to 0, the drive will skip this segment speed command and execute the next segment.

3) Switch through the external IN port (P10.00=2)

P10.00 is set to 2 to select the external IN port switching mode. After setting the parameter P10.01 according to the total number of execution segments, and set the corresponding segment command value, running time, acceleration/deceleration time and other parameters according to the requirements, the drive will select the speed command value of the corresponding segment number according to the ON/OFF combination of external IN (multi-segment operation command switch x).

Mode description	Running curve
<ul style="list-style-type: none"> ● If the segment number is updated, it can run continuously ● The segment number is determined by the IN terminal logic ● The interval time between segments is determined by the command delay of the host computer ● If the servo enable is valid, the cycle running state will always be maintained. 	<p>x, y: segment number, the logical relationship between segment number and IN terminal is as follows:</p> <ul style="list-style-type: none"> ● The running time of a certain segment is not affected by the parameter setting value. During the speed command operation of a certain segment, if the segment number changes, it will immediately switch to the new segment number to run.

When the multi-segment position operation mode is set to IN switching operation, please configure the 4 IN terminals of the drive as functions 14~17 (FunIN.14~FunIN.17: multi-segment running command switching), and confirm the valid logic of IN terminal. At the same time, one IN terminal of the servo drive can be configured as function 19 (FunIN.19: speed command direction setting) to switch the speed command direction.

Coding	Name	Function name	Function																														
FunIN.14	CMD1	Multi-segment running command switching 1	The multi-segment segment number is a 4-digit binary number, and the corresponding relationship between CMD1~CMD4 and the segment number is as follows: <table border="1" style="margin: 10px auto;"> <thead> <tr> <th>CMD4</th> <th>CMD3</th> <th>CMD2</th> <th>CMD1</th> <th>Segment number</th> </tr> </thead> <tbody> <tr> <td>0</td> <td>0</td> <td>0</td> <td>0</td> <td>1</td> </tr> <tr> <td>0</td> <td>0</td> <td>0</td> <td>1</td> <td>2</td> </tr> <tr> <td colspan="5" style="text-align: center;">.....</td> </tr> <tr> <td>1</td> <td>1</td> <td>1</td> <td>0</td> <td>15</td> </tr> <tr> <td>1</td> <td>1</td> <td>1</td> <td>1</td> <td>16</td> </tr> </tbody> </table>	CMD4	CMD3	CMD2	CMD1	Segment number	0	0	0	0	1	0	0	0	1	2					1	1	1	0	15	1	1	1	1	16
CMD4	CMD3	CMD2		CMD1	Segment number																												
0	0	0		0	1																												
0	0	0		1	2																												
.....																																	
1	1	1	0	15																													
1	1	1	1	16																													
FunIN.15	CMD2	Multi-segment running command switching 2																															
FunIN.16	CMD3	Multi-segment running command switching 3																															
FunIN.17	CMD4	Multi-segment running command switching 4																															

FunIN.19	DIR-S EL	Speed command direction setting	In multi-segment IN switching operation mode, used to set the speed command direction Invalid: keep the original command direction Valid: speed command direction
----------	-------------	------------------------------------	--

(2) Multi-segment speed running curve setting

Take the segment 1 speed command as an example, the relevant parameters are as follows:

★ Associated parameter description

Parameter	Name	Range	Unit	Function	Setting method	Effective time	Default
P10.03	Acceleration time constant 1	1~65535	ms	Set the first group acceleration and deceleration time constant	Set when running	Effective immediately	200
P10.04	Deceleration time constant 1	1~65535	ms		Set when running	Effective immediately	200
P10.15	Acceleration time constant 7	1~65535	ms	Set the 7th group acceleration and deceleration time constant	Set when running	Effective immediately	200
P10.16	Deceleration time constant 7	1~65535	ms		Set when running	Effective immediately	200
P10.20	Segment 1 speed command	-6000~6000	rpm	Set the first segment speed command value	Set when running	Effective immediately	100
P10.21	Segment 1 speed command running time	0~65535	ms	Set the first segment command running time	Set when running	Effective immediately	10
P10.22	Segment 1 speed command acceleration and deceleration time constant selection	1~7	-	Select the first segment acceleration and deceleration mode	Set when running	Effective immediately	1

There are 7 groups of acceleration and deceleration time for selection in the multi-segment speed command parameters, except for the 1 to 16 segments of command value and command running time. The default mode is acceleration and deceleration time constant 1. In the multi-segment speed, P10.00=1, the end of a single operation is taken as an example, and the actual acceleration and deceleration time and running time are explained:

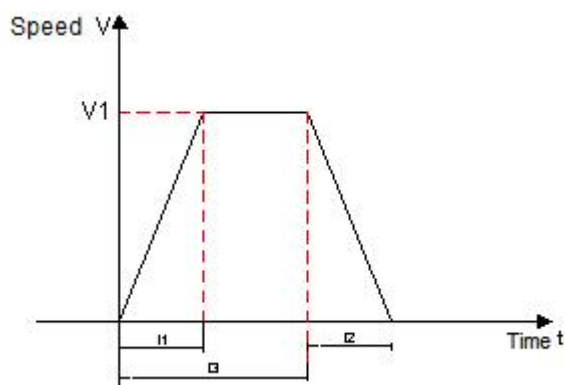

As shown in the figure above, the speed command of this segment is V_1 , and the actual acceleration time t_1 is:

$$t_1 = \frac{V_1}{1000} * \text{The acceleration time of the speed setting}$$

Actual deceleration time t_2 :

$$t_2 = \frac{V_1}{1000} * \text{The deceleration time of the speed setting}$$

Running time: the shift time when the previous speed command is switched to this speed command + the constant speed running time of this segment, as shown in t_3 in the figure.

3. The speed command source is communication control speed command (P04.00=2)

★ Associated parameter description

Parameter	Name	Range	Unit	Function	Setting method	Effective time	Default
P04.60 P04.61	Number of communication command pulses	0~ 107374 1824	Command unit	Set the number of command pulses for communication control operation	Set when running	Effective immediately	50000
P04.62	Communication control speed	0~6000	rpm	Set the maximum speed for communication control operation	Set when running	Effective immediately	1000
P04.63	Communication control acceleration time constant	1~ 65535	ms	Set the time for the motor speed to uniformly accelerate from 0rpm to 1000rpm	Set when running	Effective immediately	200
P04.64	Communication control deceleration time constant	1~ 65535	ms	Set the time for the motor speed to uniformly decelerate from 1000rpm to 0rpm	Set when running	Effective immediately	200
P04.65	Internal demo operation mode	0~1	-	Set the operation mode of internal demo operation 0: Motor reciprocating 1: Motor runs in one direction	Set when running	Effective immediately	0

P04.66	Internal demo start running direction	0~1	-	Set the starting direction of the internal demo run 0: positive direction 1: negative direction	Set when running	Effective immediately	0
P04.67	Number of internal demo runs	0~65535	-	Set the number of runs of internal demo run	Set when running	Effective immediately	0
P12.10	Communication control start-stop command	0~6	-	Start-stop command for driver communication operation	Set when running	Effective immediately	6
P12.12	Internal demo waiting time	0~65535	ms	Set the waiting time for the internal demo operation	Set when running	Effective immediately	100
P12.13	Internal demo start-stop command	0~2	-	Start-stop command for the internal demo operation of the drive	Set when running	Effective immediately	0
P01.33	Emergency stop deceleration time constant	1~65535	ms	Set the time for the motor speed to uniformly decelerate from 1000rpm to 0rpm during emergency stop	Set when running	Effective immediately	30

The startup method is as follows:

- ◆ The motor works in the communication control mode: write the start/stop command for operation through P12.10, and the motor will run in accordance with the running curve determined by the command stroke, speed and acceleration/deceleration time constant set by P04.60~P04.64.

Value written in P12.10	Description
0	Write: trigger motor to decelerate to stop. After the motor responds to the start-stop command, set P12.10 to 6.
1	Write: trigger the motor to run forward of the running command set by P04.60 and then stop. After the motor responds to the start-stop command, set P12.10 to 6.
2	Write: trigger the motor to run reversely of the running command set by P04.60 and then stop. After the motor responds to the start-stop command, set P12.10 to 6.
3	Write: trigger the motor to jog forward. After the motor responds to the start-stop command, set P12.10 to 6.
4	Write: trigger the motor to jog reverse. After the motor responds to the start-stop command, set P12.10 to 6.
5	Write: trigger motor emergency stop. After the motor responds to the start-stop command, set P12.10 to 6.
6	Write: meaningless. Read: indicating that the motor is running or waiting to be triggered to run.

- ◆ The motor works in cycle operation (demonstration) mode: write the start-stop command of the demonstration through P12.13. In the demo running mode, the motor will start in reciprocating or single direction (P04.65=0/1) according to the running command, speed, acceleration and deceleration time constant set by P04.60~P04.64, and start in positive or negative direction (P04.66=0/1), run the number of times set by P04.67. After completing the set running command each time and setting the delay time by P12.12, restart again and run in this cycle.

Value written in P12.13	Description
0	Write: stop the running of the demo mode. Read: indicates that the motor is waiting to be triggered to run.
1	Write: start the running of the demo mode; set P12.13 to 2 after the motor responds to the start-stop command.
2	Write: meaningless. Read: indicates that the motor is working in demo mode.

4. The speed command source is IO control (P04.00=3)

- ★ Associated parameter description

Parameter	Name	Range	Unit	Function	Setting method	Effective time	Default
P04.16	IO jog forward speed	0~6000	rpm	Set the maximum speed of the motor running forward	Set when running	Effective immediately	200
P04.17	IO jog reversal speed	0~6000	rpm	Set the maximum speed of the motor running in reverse	Set when running	Effective immediately	200
P04.18	IO jog acceleration time constant	1~65535	ms	Set the time for the motor speed to uniformly accelerate from 0rpm to 1000rpm	Set when running	Next run	100
P04.19	IO jog deceleration time constant	1~65535	ms	Set the time for the motor speed to uniformly decelerate from 1000rpm to 0rpm	Set when running	Next run	100
P01.33	Emergency stop deceleration time constant	1~65535	ms	Set the time for the motor speed to uniformly decelerate from 1000rpm to 0rpm during emergency stop	Set when running	Effective immediately	30

The startup method is as follows:

1) The motor works in: start-stop + direction mode

Set the function of the input terminal to control the motor, assuming that IN3 controls the start and stop of the motor, and IN4 controls the direction of the motor:

Coding	Name	Function name	Function
FunIN.24	USER1	Motor start and stop	IN3 is used to control the start and stop of the motor: Pn02.04=24 Normally open polarity (when IN3 is connected to 0V, the motor will start, and when IN3 is connected to 24V, the motor will stop): Pn02.05=0 Normally closed polarity (the motor stops when IN3 is connected to 0V, and the motor starts when IN3 is connected to 24V): Pn02.05=1
FunIN.19	DIR-SEL	Speed command direction setting	IN4 is used to control the running direction of the motor: Pn02.06=19 Normally open polarity (when IN4 is connected to 0V, the motor is reversed, when IN4 is connected to 24V, the motor is forward): Pn02.07=0 Normally closed polarity (when IN4 is connected to 0V, the motor rotates forward, when IN4 is connected to 24V, the motor reverses): Pn02.07=1.

The actual running direction of the motor is as follows:

P01.01 (Rotation direction selection)	Speed command direction setting	The actual running direction of the motor
0	Invalid	CCW
	Valid	CW
	Invalid	CW
	Valid	CCW
1	Invalid	CW
	Valid	CCW
	Invalid	CCW
	Valid	CW

2) The motor works in: forward + reverse mode

Set the function of the input terminal to control the motor, assuming that IN3 controls the motor to run forward, and IN4 controls the motor to reverse:

Coding	Name	Function name	Function
FunIN.25	USER2	Motor forward	IN3 is used to control the start and stop of the motor: Pn02.04=25 Normally open polarity (when IN3 is connected to 0V, the motor runs forward, when IN3 is connected to 24V, the motor stops): Pn02.05=0 Normally closed polarity (when IN3 is connected to 0V, the motor stops, when IN3 is connected to 24V, the motor runs forward): Pn02.05=1
FunIN.26	USER3	Motor reverse	IN4 is used to control the running direction of the motor: Pn02.06=26 Normally open polarity (when IN4 is connected to 0V, the motor runs reverse, and when IN4 is connected to 24V, the motor stops): Pn02.07=0 Normally closed polarity (the motor stops when IN4 is connected to 0V, and the motor runs reverse when IN4 is connected to 24V): Pn02.07=1.

Remark:

- ◆ The motor will not respond to the speed start-stop command in the other direction during running. For example: the motor is rotating forward at this time, even if the reverse signal is valid at this time, the motor will continue to rotate forward. If you really need to reverse, please cancel the forward signal first, and then input the reverse signal.
- ◆ During the running of the motor, the motor speed can be modified in real time by means of communication, and the drive can respond immediately.

5. The source of speed command is analog speed control (P04.00=4)

★ Associated parameter description

Parameter	Name	Range	Unit	Function	Setting method	Effective time	Default
P04.02	Analog channel selection	0~1	-	Set analog speed control analog command input channel 0: analog channel AN1 1: analog channel AN2	Set when running	Effective immediately	0
P04.18	Acceleration time constant	1~65535	ms	Set the time for the motor speed to uniformly accelerate from 0rpm to 1000rpm	Set when running	Next run	100
P04.19	Deceleration time constant	1~65535	ms	Set the time for the motor speed to decelerate uniformly from 1000rpm to 0rpm	Set when running	Next run	100
P01.33	Emergency stop deceleration time constant	1~65535	ms	Set the time for the motor speed to uniformly decelerate from 1000rpm to 0rpm during emergency stop	Set when running	Effective immediately	30
P02.64	Analog channel AN1 offset	0~65535	mv	Set the offset of analog input channel AN1	Set when running	Effective immediately	0
P02.65	Analog channel AN1 low-pass filter	0~65535	Hz	Set the low-pass filter cutoff frequency of analog input channel AN1	Set when running	Effective immediately	100
P02.66	Analog channel AN1 dead zone	0~65535	mv	Set the dead zone of analog input channel AN1	Set when running	Effective immediately	50
P02.67	Analog channel AN1 zero drift	0~65535	mv	Set the zero drift of analog input channel AN1	Set when running	Effective immediately	0
P02.68	Analog channel AN2 offset	0~65535	mv	Set the offset of analog input channel AN2	Set when running	Effective immediately	0

P02.69	Analog channel AN2 low-pass filter	0~ 65535	Hz	Set the low-pass filter cutoff frequency of analog input channel AN2	Set when running	Effective immediately	100
P02.70	Analog channel AN2 dead zone	0~ 65535	mv	Set the dead zone of analog input channel AN2	Set when running	Effective immediately	50
P02.71	Analog channel AN2 zero drift	0~ 65535	mv	Set the zero drift of analog input channel AN2	Set when running	Effective immediately	0
P02.72	Analog channel AN1 sampling digital value	-	-	Display the sampling value of the current analog input channel AN1	-	-	display
P02.73	Analog channel AN2 sampling digital value	-	-	Display the sampling value of the current analog input channel AN2	-	-	display
P02.74	Analog quantity channel AN1 sampling voltage value	-	mv	Display the voltage value of the current analog input channel AN1	-	-	display
P02.75	Analog quantity channel AN2 sampling voltage value	-	mv	Display the voltage value of the current analog input channel AN2	-	-	display
P02.76	The current actual input voltage value of analog channel AN1	-	mv	Display the actual voltage value of the current analog input channel AN1	-	-	display
P02.77	The current actual input voltage value of analog channel AN2	-	mv	Display the actual voltage value of the current analog input channel AN2	-	-	display
P02.78	Speed value corresponding to 10V	0~ 6000	rpm	Set the corresponding motor speed when the analog input voltage is 10V	Set when running	Effective immediately	3000
P02.79	Torque value corresponding to 10V	0~ 3000	0.1%	Set the corresponding motor torque when the analog input voltage is 10V	Set when running	Effective immediately	1000

P02.80	Analog channel zero drift setting	0~2	-	Calibration of analog channel zero drift 1: Calibrate analog channel AN1 2: Calibrate analog channel AN2 After the analog channel zero drift calibration is over, this parameter automatically becomes 0	Set when running	Effective immediately	0
P02.81	Analog channel dead zone mode	0~1	-	Set the dead zone mode of analog input	Set when running	Effective immediately	0

The startup method is as follows:

1) The motor works in: start-stop + direction mode

Set the Function of the input terminal to control the motor, assuming that IN3 controls the start and stop of the motor, and IN4 controls the direction of the motor:

Coding	Name	Function name	Function
FunIN.24	USER1	Motor start and stop	IN3 is used to control the start and stop of the motor: Pn02.04=24 Normally open polarity (IN3 is connected to 0V motor to start, IN3 is connected to 24V motor to stop): Pn02.05=0 Normally closed polarity (IN3 is connected to 0V motor to stop, IN3 is connected to 24V motor to start): Pn02.05=1
FunIN.19	DIR-SEL	Speed command direction setting	IN4 is used to control the running direction of the motor: Pn02.06=19 Normally open polarity (IN4 is connected to 0V motor for reverse rotation, IN4 is connected to 24V motor for forward rotation): Pn02.07=0 Normally closed polarity (IN4 is connected to 0V motor for forward rotation, IN4 is connected to 24V motor for reverse rotation): Pn02.07=1.

The actual running direction of the motor is as follows:

P01.01 (Rotation direction selection)	Speed command direction setting	The actual running speed of the motor
0	Invalid	CCW
	Valid	CW
	Invalid	CW
	Valid	CCW
1	Invalid	CW
	Valid	CCW
	Invalid	CCW
	Valid	CW

2) The motor works in: forward + reverse mode

Set the Function of the input terminal to control the motor, assuming that IN3 controls the motor to run forward, and IN4 controls the motor to reverse:

Coding	Name	Function name	Function
FunIN.25	USER2	Motor forward	IN3 is used to control the start and stop of the motor: Pn02.04=25 Normally open polarity (when IN3 is connected to 0V, the motor runs forward, IN3 is connected to 24V motor to stop): Pn02.05=0 Normally closed polarity (when IN3 is connected to 0V, the motor stops, IN3 is connected to 24V motor to run forward): Pn02.05=1
FunIN.26	USER3	Motor reverse	IN4 is used to control the running direction of the motor: Pn02.06=26 Normally open polarity (when IN4 is connected to 0V, the motor run reverse, and IN4 is connected to 24V to stop the motor): Pn02.07=0 Normally closed polarity (when IN4 is connected to 0V, the motor stops, and IN4 is connected to 24V, the motor run reverse): Pn02.07=1

Remark:

- ◆ When the motor is running, it will not respond to the speed start-stop command in the other direction. For example, the motor is rotating forward at this time, and even if the reverse signal is valid at this time, the motor will continue to rotate. If it is necessary to reverse, please cancel the forward signal first, and then input the reverse signal.
- ◆ During the running of the motor, the running speed of the motor can still be modified in real time through communication, and the drive responds immediately.

6.2.2.Speed Related Output Signal

To use the speed signal output function, you need to set the drive output port function parameter to the corresponding output function value.

1. Motor rotation signal

When the absolute value of the actual motor speed after filtering reaches P04.08 (motor rotation speed threshold), the motor can be regarded as rotating. At this time, the servo drive outputs a motor rotation signal, which is used to transmit that the motor has rotated. Conversely, when the absolute value of the actual motor speed is less than P04.08, it is considered that the motor is not in a rotating state. The judgment of the motor rotating output signal is not affected by the drive operation state and control mode.

★ Associated parameter description

Parameter	Name	Range	Unit	Function	Setting method	Effective time	Default
P04.08	Motor rotation speed threshold	0~1000	rpm	Set the motor rotation signal judgment threshold	Set when running	Effective immediately	20

2. Speed consistent signal

In speed control mode, when the absolute value of the deviation between the actual speed of the servo motor and the speed command after filtering is within the value range set by P04.09, it is considered that the actual speed of the motor reaches the speed command setting value, and the drive outputs a speed consistent signal at this time. Conversely, after filtering, the absolute value of the deviation between the actual speed of the servo motor and the speed command exceeds the set threshold, and the speed consistent signal is invalid.

★ Associated parameter description

Parameter	Name	Range	Unit	Function	Setting method	Effective time	Default
P04.09	Speed consistent signal threshold	0~1000	rpm	Set speed consistent signal threshold	Set when running	Effective immediately	20

3. Speed arrival signal

When the absolute value of the actual speed of the servo motor after filtering exceeds the set value of P04.10, it is considered that the actual speed of the servo motor has reached the expected value, and the servo drive can output a speed arrival signal at this time. Conversely, if the absolute value of the actual speed of the servo motor after filtering is not greater than the set value, the speed arrival signal is invalid. The judgment of the motor speed reaching the output signal is not affected by the drive operation state and control mode.

★ Associated parameter description

Parameter	Name	Range	Unit	Function	Setting method	Effective time	Default
P04.10	Speed arrival signal threshold	0~6000	rpm	Set speed arrival signal judgment threshold	Set when running	Effective immediately	500

4. Zero speed signal

When the absolute value of the actual speed of the servo motor after filtering is less than the value set in P04.11, it is considered that the actual speed of the servo motor is close to static, and the servo drive can output a zero speed signal at this time. Conversely, if the absolute value of the actual speed of the servo motor is greater than the set value, it is considered that the motor is not at a standstill and the zero speed signal is invalid. The judgment of the zero speed output signal of the motor is not affected by the operating state and control mode of the drive.

★ Associated parameter description

Parameter	Name	Range	Unit	Function	Setting method	Effective time	Default
P04.11	Zero speed output signal threshold	0~6000	rpm	Set the threshold for determining the zero-speed output signal of the motor	Set when running	Effective immediately	10

6.3. Torque Control Mode

6.3.1. Torque Command Input Setting

In the torque control mode, the speed command source should first be set via parameter P05.00.

★ Associated parameter description

Parameter	Name	Range	Unit	Function	Setting method	Effective time	Default
P05.00	Torque command source A	0~2	-	Set the command source of torque command source A 0: Digital setting (P05.03) 1: Analog channel AI1 (reserved) 2: Analog channel AI2 (reserved)	Set after stopping	Effective immediately	0
P05.01	Torque command source B	0~2	-	Set the command source of torque command source B 0: Digital setting (P05.03) 1: Analog channel AI1 (reserved) 2: Analog channel AI2 (reserved)	Set after stopping	Effective immediately	0
P05.02	Torque command source	0~3	-	Set the torque command source in torque mode 0: Torque command is set by command source A 1: Torque command is set by command source B 2: Torque command is given by (P05.20) communication 3: Torque command is combined by command source A/B (reserved)	Set after stopping	Effective immediately	0
P02.64	Analog channel AN1 offset	0~65535	mv	Set the offset of analog input channel AN1	Set when running	Effective immediately	0
P02.65	Analog channel AN1 low-pass filter	0~65535	Hz	Set the low-pass filter cutoff frequency of analog input channel AN1	Set when running	Effective immediately	100
P02.66	Analog channel AN1 dead zone	0~65535	mv	Set the dead zone of analog input channel AN1	Set when running	Effective immediately	50

P02.67	Analog channel AN1 zero drift	0~65535	mv	Set the zero drift of analog input channel AN1	Set when running	Effective immediately	0
P02.68	Analog channel AN2 offset	0~65535	mv	Set the offset of analog input channel AN2	Set when running	Effective immediately	0
P02.69	Analog channel AN2 low-pass filter	0~65535	Hz	Set the low-pass filter cutoff frequency of analog input channel AN2	Set when running	Effective immediately	100
P02.70	Analog channel AN2 dead zone	0~65535	mv	Set the dead zone of analog input channel AN2	Set when running	Effective immediately	50
P02.71	Analog channel AN2 zero drift	0~65535	mv	Set the zero drift of analog input channel AN2	Set when running	Effective immediately	0
P02.72	Analog channel AN1 sampling digital value	-	-	Display the sampling value of the current analog input channel AN1	-	-	Display
P02.73	Analog channel AN2 sampling digital value	-	-	Display the sampling value of the current analog input channel AN2	-	-	Display
P02.74	Analog quantity channel AN1 sampling voltage value	-	mv	Display the voltage value of the current analog input channel AN1	-	-	Display
P02.75	Analog quantity channel AN2 sampling voltage value	-	mv	Display the voltage value of the current analog input channel AN2	-	-	Display
P02.76	The current actual input voltage value of analog channel AN1	-	mv	Display the actual voltage value of the current analog input channel AN1	-	-	Display
P02.77	The current actual input voltage value of analog channel AN2	-	mv	Display the actual voltage value of the current analog input channel AN2	-	-	Display
P02.78	Speed value corresponding to 10V	0~6000	rpm	Set the corresponding motor speed when the analog input voltage is 10V	Set when running	Effective immediately	3000
P02.79	Torque value corresponding to 10V	0~3000	0.1%	Set the corresponding motor torque when the analog input voltage is 10V	Set when running	Effective immediately	1000

P02.80	Analog channel zero drift setting	0~2	-	Calibration of analog channel zero drift 1: Calibrate analog channel AN1 2: Calibrate analog channel AN2 After the analog channel zero drift calibration is over, this parameter automatically becomes 0	Set when running	Effective immediately	0
P02.81	Analog channel dead zone mode	0~1	-	Set the dead zone mode of analog input	Set when running	Effective immediately	0

1. Torque operating mode 1

In this working mode, the positive and negative symbols of the torque command are used to realize the forward and reverse operation of the motor torque mode, and there is no acceleration and deceleration control process for the operation of the motor. This function requires P05.26 to be set to 0.

★ Associated parameter description

Parameter	Name	Range	Unit	Function	Setting method	Effective time	Default
P05.03	Digital given	-3000~3000	0.1%	When the command source P05.00/P05.01 is set to 0 (when digital is given), set the torque value for torque mode operation	Set when running	Next run	200
P05.05	Torque ramp	1~65535	0.1%/s	Set the unit time increment of torque command	Set when running	Next run	3000
P05.12	Speed limit source	0~1	-	Set the maximum speed limit source in torque mode 0: Internal setting (P05.14/P05.15) 1: External analog quantity (reserved)	Set when running	Next run	0
P05.14	Torque control forward speed limit value	0~6000	rpm	Set the forward speed limit value in torque control mode	Set when running	Next run	3000
P05.15	Torque control negative speed limit value	0~6000	rpm	Set the negative speed limit value in torque control mode	Set when running	Next run	3000

P05.16	Torque reaches the reference value	0~65535	0.1%	Set the reference value of the motor torque when the running torque reaches the signal output	Set when running	Next run	0
P05.17	Torque reaches the effective value	0~65535	0.1%	Set the effective value of the motor torque when the running torque reaches the signal output	Set when running	Next run	100
P05.18	Torque reaches invalid value	0~65535	0.1%	Set the invalid value of the motor torque when the running torque reaches the signal output	Set when running	Next run	50
P05.19	Torque mode torque arrival signal detection time	0~65535	ms	Set the torque detection time of the motor torque when the running torque reaches the signal output	Set when running	Next run	50
P05.20	Communication given torque command	0~3000	0.1%	When P05.02 is set to 3, set the torque command value in torque mode	Set when running	Next run	200
P05.26	Torque operation mode selection	0~1	-	Set the working mode of torque operation	Set after stopping	Next run	0

Starting mode:

- ◆ After the above-mentioned related parameters are set for the motor, the upper computer will give an enable signal, and the motor torque will run according to the set torque and speed limit values.

2. Torque operating mode 2

In this working mode, the motor accelerates and decelerates according to the set speed trajectory, and the speed curve of the motor operation is planned. After the motor torque is reached, the internal operation mode can be selected, such as free running state, continuing to maintain the set torque, etc.

This function requires P05.26 to be set to 1.

★ Associated parameter description

Parameter	Name	Range	Unit	Function	Setting method	Effective time	Default
P05.03	Digital given	-3000~3000	0.1%	When the command source P05.00/P05.01 is set to 0 (when digital is given), set the torque value for torque mode operation	Set when running	Next run	200
P05.12	Speed limit source	0~1	-	Set the maximum speed limit source in torque mode	Set when running	Next run	0

				0: Internal setting (P05.14/P05.15) 1: External analog quantity (reserved)			
P05.14	Torque control forward speed limit value	0~6000	rpm	Set the forward speed limit value in torque control mode	Set when running	Next run	3000
P05.15	Torque control negative speed limit value	0~6000	rpm	Set the negative speed limit value in torque control mode	Set when running	Next run	3000
P05.16	Torque reaches the reference value	0~65535	0.1%	Set the reference value of the motor torque when the running torque reaches the signal output	Set when running	Next run	0
P05.17	Torque reaches the effective value	0~65535	0.1%	Set the effective value of the motor torque when the running torque reaches the signal output	Set when running	Next run	100
P05.18	Torque reaches invalid value	0~65535	0.1%	Set the invalid value of the motor torque when the running torque reaches the signal output	Set when running	Next run	50
P05.19	Torque mode torque arrival signal detection time	0~65535	ms	Set the torque detection time of the motor torque when the running torque reaches the signal output	Set when running	Next run	50
P05.20	Communication given torque command	0~3000	0.1%	When P05.02 is set to 3, set the torque command value in torque mode	Set when running	Next run	200
P05.21	Torque running acceleration time constant	1~65535	ms	Set the time for the motor speed to accelerate uniformly from 0rpm to 1000rpm	Set when running	Next run	100
P05.22	Torque running deceleration time constant	1~65535	ms	Set the time for the motor speed to decelerate uniformly from 1000rpm to 0rpm	Set when running	Next run	100
P05.23	Torque mode torque holding time	0~65535	ms	Set the torque holding time after the motor torque reaches the effective signal output 0: the motor holds the torque and waits for the upper computer to control the shutdown Other values: After the motor	Set when running	Next run	500

				holding torque reaches the time set in P05.23, it will stop automatically			
P05.24	Torque mode shutdown mode	0~4	-	Set the operating mode after torque stop in torque control mode: 0: Motor running torque is set to 0 (offline) Other: Do not deal with	Set when running	Next run	0
P05.25	Torque mode communication start-stop command	0~2	-	Used for communication to trigger the start and stop of the motor torque mode, or for software to force the motor torque to run in forward and reverse rotation (at this time, the motor start/stop is only controlled by the servo enable signal) 0: Stop 1: Forward start operation 2: Reverse start operation	Set when running	Effective immediately	0
P05.26	Torque operation mode selection	0~1	-	Set the working mode of torque operation	Set after stopping	Next run	0

There are two ways to start up as follows:

- (1) Set the corresponding IN terminal function to "FunIN.24 (torque forward)", "FunIN.25 (torque reverse)" of [Group P02:Terminal Input/Output Parameters](#), and set the correct polarity according to the external IN terminal. Use external input to trigger torque mode operation (trigger signal is level effective).
- (2) Write a specific value to P05.25 through communication:

Value written in P05.25	Description
0	Write: Torque operation stops; Read: indicates that the motor is in stop or has been stopped.
1	Write: Motor starting torque forward operation; Read: the motor is running torque forward.
2	Write: Motor starting torque reverse operation; Read: the motor is in torque reversal operation.

- ◆ In communication mode, when the motor torque is running, if you want to switch the running direction, you must first write 0 to trigger the motor to stop, then write the running start value in the opposite direction (P02.25=1/2).
- ◆ It is recommended not to mix the external input trigger control and communication trigger control, otherwise there may be abnormal conditions.

6.3.2.Speed Limit in Torque Mode

In the torque control mode, if the given torque command is too large and greater than the mechanical side load torque, the motor will continue to accelerate, overspeed may occur, and the mechanical equipment may be damaged. Therefore, in order to protect the machine, the speed of the motor must be limited.

★ Associated parameter description

Parameter	Name	Range	Unit	Function	Setting method	Effective time	Default
P05.14	Torque control forward speed limit value	0~6000	rpm	Set the forward speed limit value in torque control mode	Set when running	Next run	3000
P05.15	Torque control negative speed limit value	0~6000	rpm	Set the negative speed limit value in torque control mode	Set when running	Next run	3000

6.3.3.Torque Arrival Output

The torque arrival function is used to determine whether the actual torque command has reached the set interval. When the actual torque command reaches the torque command threshold, the drive can output the corresponding output signal (torque arrival) for the host computer to use the input/output parameters.[Group P02: Terminal Input/Output Parameters.](#)

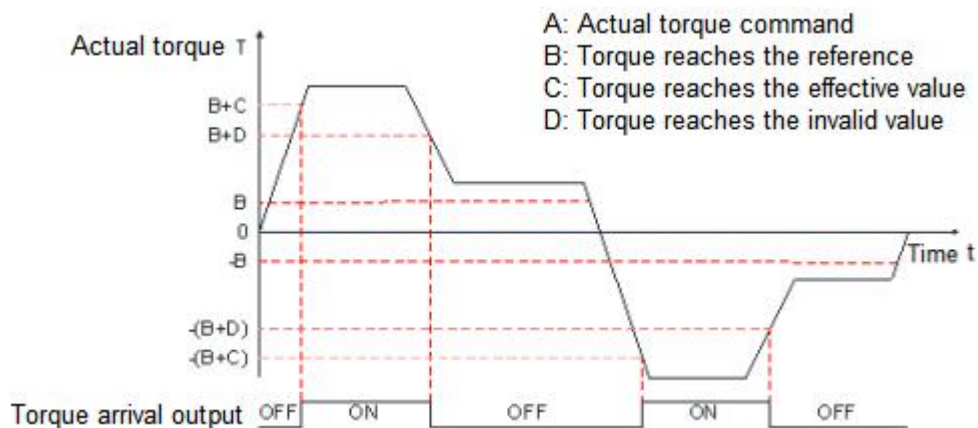

Actual torque command (The value of parameter P13.03 can be read by communication):

When the torque reaches the output signal from invalid to valid, the actual torque command must satisfy:

$$|A| \geq B + C$$

Otherwise, the torque arrival output signal remains invalid.

Conversely, when the torque arrival signal from valid to invalid, the actual torque command must satisfy:

$$|A| < B + D$$

Otherwise, the torque arrival output signal remains valid.

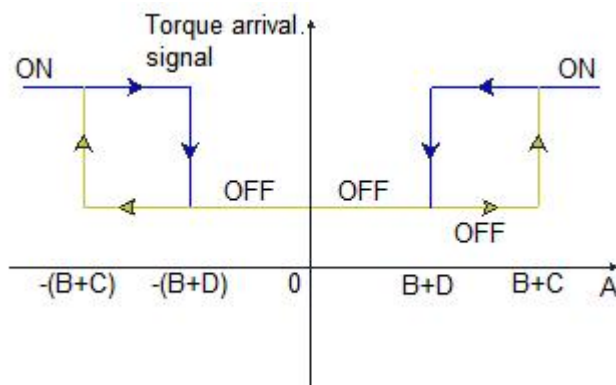

★ Associated parameter description

Parameter	Name	Range	Unit	Function	Setting method	Effective time	Default
P05.17	Torque reaches the effective value	0~65535	0.1%	Set the effective value of the motor torque when the running torque reaches the signal output	Set when running	Next run	100
P05.18	Torque reaches invalid value	0~65535	0.1%	Set the invalid value of the motor torque when the running torque reaches the signal output	Set when running	Next run	50
P05.19	Torque mode torque arrival signal detection time	0~65535	ms	Set the torque detection time of the motor torque when the running torque reaches the signal output	Set when running	Next run	50

6.4. Hybrid Control Mode

The hybrid control mode means that when the servo enable bit is ON and the servo state is running, the working mode of the servo drive can be switched between different control modes.

There are four main types of mixed control modes:

- ◆ Speed mode - Torque mode
- ◆ Position mode - Speed mode
- ◆ Position mode - Torque mode
- ◆ Position mode - Speed mode - Torque mode

Set by parameter P01.00 (control mode selection), as shown in the following table:

★ Associated parameter description

Parameter	Name	Range	Function	Setting method	Effective time	Default
P01.00	Control mode selection	0: Position control mode 1: Speed control mode 2: Torque control mode 3: EtherCAT/CANopen mode 4: Speed mode - Torque mode 5: Position mode - Speed mode 6: Position mode - Torque mode 7: Position mode - Speed mode - Torque mode	Set the control mode of the servo drive	Set after stopping	Effective immediately	0

When P01.00 is set to 4/5/6, please configure an IN terminal of the servo drive as function 10 (FunIN.10: control mode selection 1), and determine the effective logic level value of the IN terminal. When P01.00 is set to 7, please configure the two IN terminals of the servo drive as function 10 (FunIN.10: control mode selection 1) and function 29 (FunIN.29: control mode selection 2) respectively. And determine the effective logic level of these two IN terminals.

★ Associated function coding

Coding	Name	Function																		
FunIN.10	Control mode selection 1	Used to set the current control mode of servo drive in hybrid control mode:																		
		<table border="1"> <thead> <tr> <th>P01.00</th> <th>FunIN.10 logic</th> <th>Control mode</th> </tr> </thead> <tbody> <tr> <td rowspan="2">4</td> <td>Invalid</td> <td>Speed control mode</td> </tr> <tr> <td>Valid</td> <td>Torque control mode</td> </tr> <tr> <td rowspan="2">5</td> <td>Invalid</td> <td>Position control mode</td> </tr> <tr> <td>Valid</td> <td>Speed control mode</td> </tr> <tr> <td rowspan="2">6</td> <td>Invalid</td> <td>Position control mode</td> </tr> <tr> <td>Valid</td> <td>Torque control mode</td> </tr> </tbody> </table>	P01.00	FunIN.10 logic	Control mode	4	Invalid	Speed control mode	Valid	Torque control mode	5	Invalid	Position control mode	Valid	Speed control mode	6	Invalid	Position control mode	Valid	Torque control mode
		P01.00	FunIN.10 logic	Control mode																
		4	Invalid	Speed control mode																
			Valid	Torque control mode																
		5	Invalid	Position control mode																
Valid	Speed control mode																			
6	Invalid	Position control mode																		
	Valid	Torque control mode																		
FunIN.29	Control mode selection 2	Used to set the current control mode of servo drive in hybrid control mode:																		
		<table border="1"> <thead> <tr> <th>P01.00</th> <th>FunIN.29 logic</th> <th>FunIN.10 logic</th> <th>Control mode</th> </tr> </thead> <tbody> <tr> <td rowspan="3">7</td> <td>Invalid</td> <td>Invalid</td> <td>Position control mode</td> </tr> <tr> <td>Invalid</td> <td>Valid</td> <td>Speed control mode</td> </tr> <tr> <td>Valid</td> <td>-</td> <td>Torque control mode</td> </tr> </tbody> </table>	P01.00	FunIN.29 logic	FunIN.10 logic	Control mode	7	Invalid	Invalid	Position control mode	Invalid	Valid	Speed control mode	Valid	-	Torque control mode				
		P01.00	FunIN.29 logic	FunIN.10 logic	Control mode															
		7	Invalid	Invalid	Position control mode															
Invalid	Valid		Speed control mode																	
Valid	-		Torque control mode																	

7. Parameter Description

Parameter group	Parameter group description
P00	Servo drive/motor parameters
P01	Basic control parameters
P02	Terminal input/output parameters
P03	Position control parameters
P04	Speed control parameters
P05	Torque control parameters
P06	Gain parameters
P08	Communication parameters
P09	Multi-segment position parameters
P10	Multi-segment speed parameters
P13	Monitoring parameters

7.1. Group P00: Servo Drive/Motor Parameters

P00.00	Name	Motor number			Related mode	-
	Setting range	10000~65535	Unit	-	Factory setting	50604

P00.01	Name	Servo drive model			Related mode	Display
	Setting range	-	Unit	-	Factory setting	-

Display servo drive model

Display value	Description	Display value	Description	Display value	Description
0x10(16)	RS100E	0x20(30)	RS100	0x30(48)	RS100C
0x11(17)	RS200E	0x21(31)	RS200	0x31(49)	RS200C
0x12(18)	RS400E	0x22(32)	RS400	0x32(50)	RS400C
0x13(19)	RS750E	0x23(33)	RS750	0x33(51)	RS750C
0x14(20)	RS1000E	0x24(34)	RS1000	0x34(52)	RS1000C
0x15(21)	RS1500E	0x25(35)	RS1500	0x35(53)	RS1500C
0x16(22)	RS3000E	0x26(36)	RS3000	0x36(54)	RS3000C

P00.02	Name	MCU software version number			Related mode	Display
	Setting range	XXX.YY	Unit	-	Factory setting	-

P00.03	Name	FPGA software version			Related mode	Display
	Setting range	XXX.YY	Unit	-	Factory setting	-

P00.04	Name	EtherCAT software version			Related mode	Display
	Setting range	XXX.YY	Unit	-	Factory setting	-

P00.05	Name	Drive hardware version			Related mode	Display
	Setting range	XXX.YY	Unit	-	Factory setting	-

P00.06	Name	CAN software version			Related mode	Display
	Setting range	XXX.YY	Unit	-	Factory setting	-

P00.07	Name	Software non-standard ID			Related mode	Display
	Setting range	-	Unit	-	Factory setting	-

P00.08	Name	Hardware non-standard ID			Related mode	Display
	Setting range	-	Unit	-	Factory setting	-

P00.09	Name	Drive PWM update mode			Related mode	Display
	Setting range	-	Unit	-	Factory setting	-
P00.17	Name	Rated power			Related mode	-
	Setting range	1~65535	Unit	0.01KW	Factory setting	-
P00.18	Name	Rated voltage			Related mode	-
	Setting range	1~380	Unit	V	Factory setting	-
P00.19	Name	Rated current			Related mode	-
	Setting range	1~65535	Unit	0.1A	Factory setting	-
P00.20	Name	Rated speed			Related mode	-
	Setting range	1~6000	Unit	rpm	Factory setting	-
P00.21	Name	Maximum speed			Related mode	-
	Setting range	1~6000	Unit	rpm	Factory setting	-
P00.22	Name	Rated torque			Related mode	-
	Setting range	1~65535	Unit	0.01Nm	Factory setting	-
P00.23	Name	Maximum torque			Related mode	-
	Setting range	1~65535	Unit	0.01Nm	Factory setting	-
P00.24	Name	Moment of inertia Jm			Related mode	-
	Setting range	1~65535	Unit	kgcm ²	Factory setting	-
P00.25	Name	Motor magnetic pole number			Related mode	-
	Setting range	2~360	Unit	Pole-pairs	Factory setting	-
P00.26	Name	Stator resistance			Related mode	-
	Setting range	1~65535	Unit	0.001Ω	Factory setting	-
P00.27	Name	Stator inductance Lq			Related mode	-
	Setting range	1~65535	Unit	0.01mH	Factory setting	-

P00.28	Name	Stator inductance Ld			Related mode	-
	Setting range	1~65535	Unit	0.01mH	Factory setting	-

P00.29	Name	Linear back-EMF coefficient			Related mode	-
	Setting range	1~65535	Unit	0.01mV/rpm	Factory setting	-

P00.30	Name	Torque coefficient Kt			Related mode	-
	Setting range	1~65535	Unit	0.01Nm/Arms	Factory setting	-

P00.31	Name	Electric time constant Te			Related mode	-
	Setting range	1~65535	Unit	0.01ms	Factory setting	-

P00.32	Name	Mechanical time constant Tm			Related mode	-
	Setting range	1~65535	Unit	0.01ms	Factory setting	-

P00.34	Name	Encoder type			Related mode	-
	Setting range	0~4	Unit	-	Factory setting	-

Set the motor encoder type, please set this parameter correctly, otherwise the drive cannot work normally.

Set value	Encoder type
0	Reserved
1	Multi-turn absolute
2	Single-turn absolute
3	Reserved
4	Reserved

P00.35 P00.36	Name	Absolute encoder offset			Related mode	-
	Setting range	0~1073741824	Unit	P	Factory setting	0

P00.37	Name	Absolute encoder resolution			Related mode	-
	Setting range	10~23	Unit	Bit	Factory setting	17

P00.38	Name	Number of incremental encoder pulses			Related mode	-
	Setting range	1000~65535	Unit	P/r	Factory setting	10000

P00.39	Name	Encoder Z phase signal offset			Related mode	-
	Setting range	0~65535	Unit	P	Factory setting	1250

P00.40	Name	Encoder U phase signal rising edge offset			Related mode	-
	Setting range	0~65535	Unit	P	Factory setting	0

P00.41	Name	Prohibit multi-turn encoder battery fault output			Related mode	-
	Setting range	0~1	Unit	-	Factory setting	0

P00.42	Name	Multi-turn encoder resolution			Related mode	-
	Setting range	0~24	Unit	Bit	Factory setting	16

P00.43	Name	Drive power-on position calibration torque			Related mode	-
	Setting range	0~100	Unit	%	Factory setting	90

Refers to the magnitude of the torque when the driver performs position calibration by locking the motor at encoder type P00.34=3/4. The unit is the percentage of rated torque of the motor. This parameter is invalid when P00.34 is set to any other value.

P00.44	Name	Set current position as mechanical zero point			Related mode	-
	Setting range	0~1	Unit	-	Factory setting	0

In the absolute value system, the mechanical zero point is set by setting P00.44=1. The specific method is: The load moves to the mechanical zero point position through JOG, and then the current position is automatically set as the mechanical zero point by setting the parameter P00.44 as 1.

P00.45 P00.46	Name	Encoder single-turn value corresponding to the mechanical zero of the absolute value system			Related mode	-
	Setting range	0~16777216	Unit	P	Factory setting	0

In the absolute value system, it is used to save the current single-turn value of the motor encoder at the mechanical zero position. After P00.44 is set to 1, the driver will automatically update the current single-turn value of the encoder to P00.45/P00.46.

P00.47 P00.48	Name	Encoder multi-turn value corresponding to the mechanical zero of the absolute value system			Related mode	-
	Setting range	-16777216~16777216	Unit	Turn	Factory setting	0

In the absolute value system, it is used to save the current multi-turn value of the motor encoder at the mechanical zero position. After P00.44 is set to 1, the driver will automatically update the current multi-turn value of the encoder to P00.47/P00.48.

P00.49	Name	It is forbidden to use the absolute encoder position to update the current position command			Related mode	-
	Setting range	0~1	Unit	-	Factory setting	0

Whether it is forbidden to use the absolute encoder value to update the current position command P13.07

P00.50 P00.51	Name	Divided output gear ratio numerator			Related mode	-
	Setting range	1~8388608	Unit	-	Factory setting	10000

P00.52 P00.53	Name	Divided output gear denominator			Related mode	-
	Setting range	1~8388608	Unit	-	Factory setting	131072

P00.54	Name	Exchange frequency division output AB phase pulse			Related mode	-
	Setting range	0~1	Unit	-	Factory setting	0

P00.55	Name	Encoder EEPROM version number			Related mode	-
	Setting range	-	Unit	-	Factory setting	-

P00.56	Name	Rotation mode enable (frequency division output Z-phase signal width)			Related mode	-
	Setting range	0~1(1~65535)	Unit	-	Factory setting	0(8)

P00.57	Name	Frequency division output Z phase signal polarity			Related mode	-
	Setting range	0~1	Unit	-	Factory setting	0

P00.58	Name	Frequency division output Z phase initialization mode			Related mode	-
	Setting range	0~1	Unit	-	Factory setting	0

7.2. Group P01: Basic Control Parameters

P01.00	Name	Control mode selection			Related mode	-
	Setting range	0~7	Unit	-	Factory setting	0

Select the servo drive control mode.

Set value	Control mode
0	Position mode
1	Speed mode
2	Torque mode
3	EtherCAT/CANopen
4	Speed mode - Torque mode
5	Position mode - Speed mode
6	Position mode - Torque mode
7	Position mode-Speed mode - Torque mode

P01.01	Name	Rotation direction selection			Related mode	-
	Setting range	0~1	Unit	-	Factory setting	0
Set the forward direction of motor rotation when observed from the motor output shaft.						
	Set value	Direction of rotation	Remark			
	0	Take the CCW direction as the forward direction	In the case of a forward command, from the side of the motor shaft, the motor rotation direction is the CCW direction, that is, the motor rotates counterclockwise.			
	1	Take the CW direction as the forward direction	In the case of a positive command, from the side of the motor shaft, the motor rotation direction is the CW direction, that is, the motor rotates clockwise.			

P01.20	Name	The minimum value of braking resistance allowed by the drive			Related mode	Display
	Setting range	-	Unit	Ω	Factory setting	-
Check the minimum value of braking resistance allowed by a certain model of drive, which is only related to the drive model.						

P01.21	Name	Built-in braking resistance power			Related mode	Display
	Setting range	-	Unit	W	Factory setting	-
Check the built-in braking resistor power of a certain type of drive, it cannot be changed, it is only related to the servo drive model.						

P01.22	Name	Built-in braking resistance value			Related mode	Display
	Setting range	-	Unit	Ω	Factory setting	-
Check the minimum value of braking resistance allowed by a certain model of drive, which is only related to the drive model.						

P01.23	Name	Resistance heat dissipation coefficient			Related mode	-
	Setting range	1~100	Unit	-	Factory setting	20
When setting and using a braking resistor, the heat dissipation coefficient of the resistor is valid for both built-in and external braking resistors. Please set this parameter according to the actual heat dissipation conditions of the resistor. Recommended value: generally, when natural cooling, P01.23 does not exceed 30%; when forced air cooling, P01.23 does not exceed 50%.						

P01.24	Name	Braking resistance setting			Related mode	Display
	Setting range	0: Use built-in braking resistor 1: Use external braking resistor	Unit	-	Factory setting	0

P01.25	Name	External braking resistance power			Related mode	-
	Setting range	1~65535	Unit	W	Factory setting	50

P01.26	Name	External braking resistance value			Related mode	-
	Setting range	1~1000	Unit	Ω	Factory setting	10

P01.27	Name	Braking start voltage value			Related mode	-
	Setting range	1~100	Unit	V	Factory setting	68

P01.28	Name	Brake feedback detection mode (Do not set)			Related mode	-
	Setting range	0~1(Do not set)	Unit	V	Factory setting	1

P01.29	Name	Maximum continuous braking time			Related mode	-
	Setting range	0~65535	Unit	ms	Factory setting	3000

P01.33	Name	Emergency stop deceleration time constant			Related mode	-
	Setting range	1~65535	Unit	ms	Factory setting	5

Set the time for the speed to change from 1000rpm to 0rpm evenly when the motor is stopped in an emergency.

P01.36	Name	Servo enable delay off time			Related mode	-
	Setting range	0~65535	Unit	ms	Factory setting	50

Set the delay time for the servo drive to change from "enable" to "disable" when the servo drive enable signal changes from "valid" to "invalid".

P01.37	Name	Speed regulator saturation detection time			Related mode	-
	Setting range	0~65535	Unit	10ms	Factory setting	450

When the continuous saturation time of the internal speed regulator in the system exceeds this set value, a speed regulator saturation alarm will be generated. It is used to prevent excessive continuous current caused by mechanical jamming or other reasons.

- Note: When the set value is 0, the speed regulator saturation detection fault alarm is prohibited.

P01.42	Name	Command overload initial detection point			Related mode	-
	Setting range	0~300	Unit	1%	Factory setting	100

Set the initial torque point for command overload protection of the servo drive. The set value is the percentage of the rated current of the servo motor. When the current torque of the servo motor is higher than this value, the internal command overload counter of the system will count the command overload. After the count value exceeds, the servo drive will output a command overload alarm.

- Note: When the parameter P01.42 is greater than the parameter P01.43, the command overload protection detection function will be prohibited.

P01.43	Name	Command overload peak detection point			Related mode	-
	Setting range	0~300	Unit	1%	Factory setting	300

Set the peak torque point for command overload protection of the servo drive. The set value is the percentage of the rated current of the servo motor. Together with P01.42 and P01.44, it composes the command overload protection feature of the servo drive.

- Note: When the parameter P01.42 is greater than the parameter P01.43, the command overload protection detection function will be prohibited.

P01.44	Name	Command overload detection time			Related mode	-
	Setting range	0~65535	Unit	10ms	Factory setting	450

Set the command overload protection detection time, which is set based on the motor overload characteristic parameters.

P01.45	Name	Thermal overload initial detection point			Related mode	-
	Setting range	0~300	Unit	1%	Factory setting	100

Set the initial torque point for thermal overload protection of the servo driver. The thermal overload protection of the servo drive uses the method of I^2t to calculate. The set value is the percentage of the rated current of the servo motor.

- Note: When the parameter P01.45 is greater than the parameter P01.46, the thermal overload protection detection function will be prohibited.

P01.46	Name	Thermal overload peak detection point			Related mode	-
	Setting range	0~300	Unit	1%	Factory setting	300

Set the peak torque point for thermal overload protection of the servo drive. The set value is the percentage of the rated current of the servo motor. Together with P01.45 and P01.47, it composes the thermal overload protection characteristics of the servo driver.

- Note: When the parameter P01.45 is greater than the parameter P01.46, the thermal overload protection detection function will be prohibited.

P01.47	Name	Thermal overload detection time			Related mode	-
	Setting range	0~65535	Unit	10ms	Factory setting	450

Set the command overload protection detection time, which is set based on the motor thermal overload characteristic parameters.

P01.48	Name	Overvoltage detection threshold			Related mode	-
	Setting range	1~100	Unit	V	Factory setting	85

P01.49	Name	Undervoltage detection threshold			Related mode	-
	Setting range	1~100	Unit	V	Factory setting	15

7.3. Group P02: Terminal Input/Output Parameters

P02.00	Name	IN1 terminal function selection			Related mode	-
	Setting range	0~31	Unit	-	Factory setting	1

Set the IN function corresponding to the hardware IN1 terminal. Please refer to the following table for parameter setting:

Set value	IN terminal function	Set value	IN terminal function
0	FunIN.0: Normal input	16	FunIN.16: Multi-segment operation command switching 3
1	FunIN.1: Servo enable	17	FunIN.17: Multi-segment operation command switching 4
2	FunIN.2: Alarm clear	18	FunIN.18: Torque command direction setting
3	FunIN.3: Pulse command prohibition	19	FunIN.19: Speed command direction setting
4	FunIN.4: Clear position deviation	20	FunIN.20: Position command direction setting
5	FunIN.5: Positive limit signal	21	FunIN.21: Multi-segment position command enable
6	FunIN.6: Negative limit signal	22	FunIN.22: Return to origin input
7	FunIN.7: Gain switching	23	FunIN.23: Origin switch signal
8	FunIN.8: Electronic gear ratio switch	24	FunIN.24: USER1
9	FunIN.9: Zero speed clamp	25	FunIN.25: USER2
10	FunIN.10: Control mode selection 1	26	FunIN.26: USER3
11	FunIN.11: Emergency stop	27	FunIN.27: USER4
12	FunIN.12: Position command prohibition	28	FunIN.28: USER5
13	FunIN.13: Step position trigger	29	FunIN.29: Control mode selection 2
14	FunIN.14: Multi-segment operation command switching 1	30	FunIN.30: Discontinued fixed-length release
15	FunIN.15: Multi-segment operation command switching 2	31	FunIN.31: Suspend fixed-length prohibition

P02.01	Name	IN1 terminal logic selection			Related mode	-
	Setting range	0~1	Unit	-	Factory setting	0

Set the level logic of the hardware IN1 terminal when the IN function selected by IN1 is valid. Please set the effective level logic correctly according to the host computer and peripheral circuit.

Set value	IN terminal logic when IN function is valid
0	Low level
1	High level

P02.02	Name	IN2 terminal function selection			Related mode	-
	Setting range	0~31	Unit	-	Factory setting	5

P02.03	Name	IN2 terminal logic selection			Related mode	-
	Setting range	0~1	Unit	-	Factory setting	0

P02.04	Name	IN3 terminal function selection			Related mode	-
	Setting range	0~31	Unit	-	Factory setting	6
P02.05	Name	IN3 terminal logic selection			Related mode	-
	Setting range	0~1	Unit	-	Factory setting	0
P02.06	Name	IN4 terminal function selection			Related mode	-
	Setting range	0~31	Unit	-	Factory setting	23
P02.07	Name	IN4 terminal logic selection			Related mode	-
	Setting range	0~1	Unit	-	Factory setting	0
P02.08	Name	IN5 terminal function selection			Related mode	-
	Setting range	0~31	Unit	-	Factory setting	0
P02.09	Name	IN5 terminal logic selection			Related mode	-
	Setting range	0~1	Unit	-	Factory setting	0
P02.10	Name	IN6 terminal function selection			Related mode	-
	Setting range	0~31	Unit	-	Factory setting	0
P02.11	Name	IN6 terminal logic selection			Related mode	-
	Setting range	0~1	Unit	-	Factory setting	0
P02.12	Name	IN7 terminal function selection			Related mode	-
	Setting range	0~31	Unit	-	Factory setting	0
P02.13	Name	IN7 terminal logic selection			Related mode	-
	Setting range	0~1	Unit	-	Factory setting	0
P02.14	Name	IN8 terminal function selection			Related mode	-
	Setting range	0~31	Unit	-	Factory setting	0
P02.15	Name	IN8 terminal logic selection			Related mode	-
	Setting range	0~1	Unit	-	Factory setting	0

P02.16	Name	IN9 terminal function selection			Related mode	-
	Setting range	0~31	Unit	-	Factory setting	0

P02.17	Name	IN9 terminal logic selection			Related mode	-
	Setting range	0~1	Unit	-	Factory setting	0

P02.32	Name	OUT1 terminal function selection			Related mode	-
	Setting range	0~31	Unit	-	Factory setting	1

Set the OUT function corresponding to the OUT1 terminal. Refer to the following table for parameter Settings.

Set value	OUT terminal function	Set value	OUT terminal function
0	FunOUT.0: Brake	11	FunOUT.11: USER5
1	FunOUT.1: Alarm	12	FunOUT.12: USER6
2	FunOUT.2: Position reached	13	FunOUT.13: Torque reached
3	FunOUT.3: Speed reached	14	FunOUT.14: Out-of-tolerance output
4	FunOUT.4: Servo ready	15	FunOUT.15: Torque is limited
5	FunOUT.5: Internal position command stop	16	FunOUT.16: Interrupt fixed-length completion signal
6	FunOUT.6: Return to origin completed	17	FunOUT.14: Motor rotation
7	FunOUT.7: USER1	18	FunOUT.14: Consistent speed
8	FunOUT.8: USER2	19	FunOUT.14: Zero speed
9	FunOUT.9: USER3	20~30	Reserve
10	FunOUT.10: USER4	31	FunOUT.14: Universal output

P02.33	Name	OUT1 terminal logic selection			Related mode	-
	Setting range	0~1	Unit	-	Factory setting	0

Set the OUT function corresponding to the OUT1 terminal. Refer to the following table for parameter Settings.

Set value	OUT1 terminal logic when the OUT function is valid	Transistor state
0	Low level	Conduction
1	High level	Cut-off

P02.34	Name	OUT2 terminal function selection			Related mode	-
	Setting range	0~31	Unit	-	Factory setting	6

P02.35	Name	OUT2 terminal logic selection			Related mode	-
	Setting range	0~1	Unit	-	Factory setting	0

P02.36	Name	OUT3 terminal function selection			Related mode	-
	Setting range	0~31	Unit	-	Factory setting	0

P02.37	Name	OUT3 terminal logic selection			Related mode	-
	Setting range	0~1	Unit	-	Factory setting	0

P02.38	Name	OUT4 terminal function selection			Related mode	-
	Setting range	0~31	Unit	-	Factory setting	0

P02.39	Name	OUT4 terminal logic selection			Related mode	-
	Setting range	0~1	Unit	-	Factory setting	0

P02.40	Name	OUT5 terminal function selection			Related mode	-
	Setting range	0~31	Unit	-	Factory setting	0

P02.41	Name	OUT5 terminal logic selection			Related mode	-
	Setting range	0~1	Unit	-	Factory setting	0

P02.42	Name	OUT6 terminal function selection			Related mode	-
	Setting range	0~31	Unit	-	Factory setting	0

P02.43	Name	OUT6 terminal logic selection			Related mode	-
	Setting range	0~1	Unit	-	Factory setting	0

P02.52	Name	IN terminal forced effective			Related mode	-
	Setting range	0~65535	Unit	-	Factory setting	0

Set the FunIN function corresponding to the IN terminal to be forcibly valid. If the corresponding bit is set to 1, the FunIN function corresponding to the IN terminal is forcibly valid. Set to 0, no effect. As follows:

BIT	Corresponding IN terminal
7~15	Reserve
8	IN9
7	IN8
6	IN7
5	IN6
4	IN5
3	IN4
2	IN3
1	IN2
0	IN1

P02.53	Name	OUT terminal forced effective			Related mode	-
	Setting range	0~65535	Unit	-	Factory setting	0

Setting OUT terminal output to be forcibly valid. If the corresponding bit is set to 1, the OUT terminal is forcibly valid. Set to 0, no effect. As follows:

BIT	Corresponding OUT terminal
3~15	Reserve
2	OUT3
1	OUT2
0	OUT1

P02.54	Name	FunIN Function valid flag			Related mode	-
P02.55	Setting range	-	Unit	-	Factory setting	Display

Displays the effectiveness of the FunIN function of the current drive. The value "1" indicates that the FunIN function is valid, and the value "0" indicates that the FunIN function is invalid.

BIT	Description	BIT	Description
0	FunIN.0: Normal input	16	FunIN.16: Multi-segment operation command switching 3
1	FunIN.1: Servo enable	17	FunIN.17: Multi-segment operation command switching 4
2	FunIN.2: Alarm clear	18	FunIN.18: Torque command direction setting
3	FunIN.3: Pulse command prohibition	19	FunIN.19: Speed command direction setting
4	FunIN.4: Clear position deviation	20	FunIN.20: Position command direction setting
5	FunIN.5: Positive limit signal	21	FunIN.21: Multi-segment position command enable
6	FunIN.6: Negative limit signal	22	FunIN.22: Return to origin input
7	FunIN.7: Gain switching	23	FunIN.23: Origin switch signal
8	FunIN.8: Electronic gear ratio switch	24	FunIN.24: USER1
9	FunIN.9: Zero speed clamp	25	FunIN.25: USER2
10	FunIN.10: Control mode selection 1	26	FunIN.26: USER3
11	FunIN.11: Emergency stop	27	FunIN.27: USER4
12	FunIN.12: Position command prohibition	28	FunIN.28: USER5
13	FunIN.13: Step position trigger	29	FunIN.29: Control mode selection 2
14	FunIN.14: Multi-segment operation command switching 1	30	FunIN.30: Probe 1
15	FunIN.15: Multi-segment operation command switching 2	31	FunIN.31: Probe 2

P02.56	Name	The rising edge of the FunIN function latches the valid flag			Related mode	-
P02.57	Setting range	0~65535	Unit	-	Factory setting	-

Displays the effectiveness of the input function rising edge latch since the FunIN function of the current drive was cleared last time. The corresponding BIT bit field value is "1", which means that the FunIN function has detected the rising edge state, and the corresponding BIT bit field value is "0" means that the FunIN function has not detected the rising edge state. Write the value "1" to the corresponding BIT field of this parameter to clear the latch flag.

FunIN corresponds to the parameter BIT bit field, please refer to parameter P02.54/P02.55

P02.58	Name	The falling edge of the FunIN function latches the valid flag			Related mode	-
P02.59	Setting range	0~65535	Unit	-	Factory setting	-

Displays the validity of the falling edge latch of the input function since the current drive FunIN function was last reset. The corresponding BIT bit field value of "1" indicates that the FunIN function has detected the falling edge state, and the corresponding BIT bit field value of "0" indicates that the FunIN function has not detected the falling edge state.

Write the value "1" to the corresponding BIT bit field of this parameter to clear the latch flag

FunIN corresponds to the parameter BIT bit field, please refer to parameter P02.54/P02.55

P02.60	Name	FunOUT function valid flag			Related mode	-
P02.61	Setting range	-	Unit	-	Factory setting	Display

Display the effectiveness of the FunOUT function of the current drive. The value "1" indicates that the FunOUT function is valid, and the value "0" indicates that the FunOUT function is invalid.

Display value	Description	Display value	Description
0	FunOUT.0: Brake	11	FunOUT.11: USER5
1	FunOUT.1: Alarm	12	FunOUT.12: USER6
2	FunOUT.2: Position reached	13	FunOUT.13: Torque reached
3	FunOUT.3: Speed reached	14	FunOUT.14: Out-of-tolerance output
4	FunOUT.4: Servo ready	15	FunOUT.15: Torque is limited
5	FunOUT.5: Internal position command stop	16	FunOUT.16 : Interrupt completion signal
6	FunOUT.6: Return to origin completed	17	FunOUT.17: Motor rotation
7	FunOUT.7: USER1	18	FunOUT.18: Consistent speed
8	FunOUT.8: USER2	19	FunOUT.19: Zero speed signal
9	FunOUT.9: USER3	15~30	Reserve
10	FunOUT.10: USER4	31	Universal output

P02.62	Name	Physical output enable			Related mode	-
	Setting range	0~65535	Unit	-	Factory setting	0

When the output function of the OUT port is set to "FunOUT.31 general output", the output status of the OUT port of the servo drive can be controlled by operating the P02.62 and P02.63 parameters.

BIT	Set value	Corresponding to IN terminal
3~15	-	Reserve
2	0	0: OUT3 output port is not controlled by BIT2 of P02.63
	1	1: OUT3 output port is controlled by BIT2 of P02.63
1	0	0: OUT2 output port is not controlled by BIT1 of P02.63
	1	1: OUT2 output port is controlled by BIT1 of P02.63
0	0	0: OUT1 output port is not controlled by BIT0 of P02.63
	1	1: OUT1 output port is controlled by BIT0 of P02.63

P02.63	Name	Physical output status			Related mode	-
	Setting range	0~65535	Unit	-	Factory setting	0

When the output function of the OUT port is set to "FunOUT.31 general output", the output status of the OUT port of the servo driver can be controlled by operating the P02.62 and P02.63 parameters. Only when the corresponding bit field of the P02.62 parameter is set to "1" (enable), the OUT port of the servo driver is controlled by the P02.63 parameter.

BIT	Set value	Corresponding to IN terminal
3~15	-	Reserve
2	0	0: OUT3 output port optocoupler is off
	1	1: OUT3 output port optocoupler is on
1	0	0: OUT2 output port optocoupler is off
	1	1: OUT2 output port optocoupler is on
0	0	0: OUT1 output port optocoupler is off
	1	1: OUT1 output port optocoupler is on

P02.64	Name	Analog quantity channel AN1 bias			Related mode	-
	Setting range	0~65535	Unit	mv	Factory setting	0

P02.65	Name	Analog channel AN1 low pass filter cut-off frequency			Related mode	-
	Setting range	0~65535	Unit	Hz	Factory setting	100

P02.66	Name	Analog channel AN1 dead zone			Related mode	-
	Setting range	0~65535	Unit	mv	Factory setting	50

P02.67	Name	Analog channel AN1 zero drift			Related mode	-
	Setting range	0~65535	Unit	mv	Factory setting	0

P02.68	Name	Analog channel AN2 offset			Related mode	-
	Setting range	0~65535	Unit	mv	Factory setting	0

P02.69	Name	Analog channel AN2 low pass filter cut-off frequency			Related mode	-
	Setting range	0~65535	Unit	Hz	Factory setting	100

P02.70	Name	Analog channel AN2 dead zone			Related mode	-
	Setting range	0~65535	Unit	mv	Factory setting	50

P02.71	Name	Analog channel AN2 zero drift			Related mode	-
	Setting range	0~65535	Unit	mv	Factory setting	0

P02.72	Name	Analog channel AN1 sample value			Related mode	-
	Setting range	Display	Unit	-	Factory setting	-

P02.73	Name	Analog channel AN2 sample value			Related mode	-
	Setting range	Display	Unit	-	Factory setting	-

P02.74	Name	Analog channel AN1 sample value			Related mode	-
	Setting range	Display	Unit	mv	Factory setting	-

P02.75	Name	Analog channel AN2 sample value			Related mode	-
	Setting range	Display	Unit	mv	Factory setting	-

P02.76	Name	Analog channel AN1 sample value			Related mode	-
	Setting range	Display	Unit	mv	Factory setting	-

P02.77	Name	Analog channel AN2 sample value			Related mode	-
	Setting range	Display	Unit	mv	Factory setting	-

P02.78	Name	Speed corresponding to analog 10V			Related mode	-
	Setting range	0~6000	Unit	rpm	Factory setting	3000

P02.79	Name	Torque corresponding to analog 10V			Related mode	-
	Setting range	0~3000	Unit	0.1%	Factory setting	1000

P02.80	Name	Analog zero drift calibration			Related mode	-
	Setting range	1: Calibration channel AN1 2: Calibration channel AN2 After the calibration is successful, the parameter becomes 0	Unit	-	Factory setting	0

P02.81	Name	Analog dead zone mode			Related mode	-
	Setting range	0~1	Unit	-	Factory setting	0

7.4. Group P03: Position Control Parameters

P03.00	Name	Position command source			Related mode	-
	Setting range	0~10	Unit	-	Factory setting	0











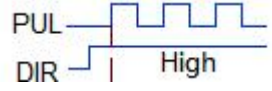

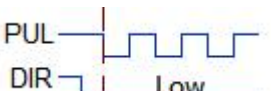
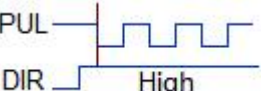
In position control mode, it is used to select the source of position command. Among them, the pulse command belongs to the external position command, and the step operation, the multi-segment position command, and the internal test position command belong to the internal position command.

Set value	Command source	Command acquisition method
0	Pulse command	The host computer or other pulse generating devices generate position commands and input them to the servo drive through hardware terminals.
1	Step size	The step displacement is set by the parameter P03.28/P03.29, and the step operation is triggered by the IN function FunIN.13.
2	Multi-segment position command	The multi-segment position operation mode is set by the P09 group parameters, and the multi-segment position operation is triggered by the IN function FunIN.21.
3	Communication control	Communication given position, speed and other parameters as well as start and stop command.

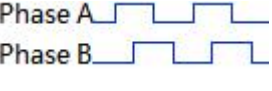
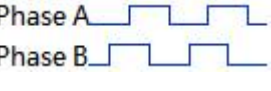
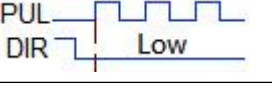
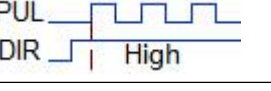
4	Communication control 2	Communication given position, and trajectory can be modified dynamically.
5	IO control	Control the jog forward and reverse rotation and fixed-length forward and reverse rotation in the motor position mode through the IN input.
5~10	-	Reserve command source, do not set.

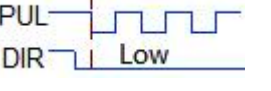
P03.02	Name	Pulse command type			Related mode	-
	Setting range	0~3	Unit	-	Factory setting	0

When setting the position command source as pulse command (P03.00=0), input the pulse form.

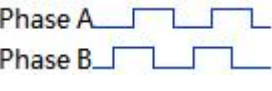
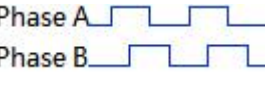
P01.01 Rotation direction selection	P03.02 Command type setting	Command type	Signal	Schematic diagram of forward pulse	Schematic diagram of reverse pulse
0	0	Pulse + direction Positive logic	PUL DIR		
	1	Pulse + direction Negative logic	PUL DIR		
	2	CW+CCW	PUL(CW) DIR(CCW)		
					
3	A phase + B phase Quadrature pulse 4 times frequency	PUL (A phase) DIR (B phase)	 ● Phase A ahead of phase B by 90°.	 ● Phase B ahead of phase A by 90°.	
1	0	Pulse + direction Positive logic	PUL DIR		
	1	Pulse + direction Negative logic	PUL DIR		
	2	CW+CCW	PUL (CW) DIR (CCW)		
					
3	A phase + B phase Quadrature pulse 4 times frequency	PUL (A phase) DIR (B phase)	 ● Phase B ahead of phase A by 90°.	 ● Phase A ahead of phase B by 90°.	

P03.04	Name	Position command average filter time constant			Related mode	-
	Setting range	1~2048	Unit	0.1ms	Factory setting	1

Set the average filter time constant of the position command (encoder unit). This function has no effect on the total number of position commands. If the set value is too large, the response delay will increase. The filter time constant should be set according to the actual situation.

P03.05	Name	Position command first-order low-pass filter time constant			Related mode	-
	Setting range	0~65535	Unit	0.1ms	Factory setting	0

Set the first-order low-pass filter time constant of the position command (encoder unit). This function has no effect on the total number of position commands. If the set value is too large, the response delay will increase. The filter time constant should be set according to the actual situation.

P03.06	Name	Number of position commands for one motor rotation			Related mode	-
P03.07	Setting range	0~8388608	Unit	P/r	Factory setting	10000

Set the number of position commands required for the motor to not rotate one revolution. P03.06 and P03.07 are combined into a 32-bit value, where P03.06 is the low 16-bit value, and P03.07 is the high 16-bit value. Subsequent use P03.06 to represent the 32-bit parameter.

When P03.06=0, the parameters of electronic gear ratio 1 and 2 (P03.08~P03.15) are valid.

When P03.06≠0, electronic gear ratio B/A=encoder resolution/P03.06, at this time, electronic gear ratio 1 and electronic gear ratio 2 are invalid.

P03.08	Name	Electronic gear ratio numerator 1			Related mode	P
P03.09	Setting range	1~1073741824	Unit	-	Factory setting	1

Set the first group of electronic gear ratio numerator for position command (command unit) frequency division. P03.08 and P03.09 are combined into a 32-bit value, where P03.08 is the low 16-bit value, and P03.09 is the high 16-bit value.

Subsequent use P03.08 to represent the 32-bit parameter.

P03.06 (number of position command pulses per motor rotation)=0 is valid.

P03.10	Name	Electronic gear ratio denominator 1			Related mode	P
P03.11	Setting range	1~1073741824	Unit	-	Factory setting	1

Set the first group of electronic gear ratio denominator for position command (command unit) frequency division. P03.10 and P03.11 are combined into a 32-bit value, where P03.10 is the low 16-bit value, and P03.11 is the high 16-bit value.

Subsequent use P03.10 to represent the 32-bit parameter.

P03.06 (number of position command pulses per motor rotation)=0 is valid.

P03.12	Name	Electronic gear ratio numerator 2			Related mode	P
P03.13	Setting range	1~1073741824	Unit	-	Factory setting	1

Set the second group of electronic gear ratio numerator for position command (command unit) frequency division. P03.12 and P03.13 are combined into a 32-bit value, where P03.12 is the low 16-bit value, and P03.13 is the high 16-bit value.

Subsequent use P03.12 to represent the 32-bit parameter.

P03.06 (number of position command pulses per motor rotation)=0 is valid.

P03.14 P03.15	Name	Electronic gear ratio denominator 2			Related mode	P
	Setting range	1~1073741824	Unit	-	Factory setting	1

Set the second group of electronic gear ratio denominator for position command(command unit) frequency division. P03.14 and P03.15 are combined into a 32-bit value, where P03.14 is the low 16-bit value, and P03.15 is the high 16-bit value. Subsequent use P03.14 to represent the 32-bit parameter.

P03.06 (number of position command pulses per motor rotation) = 0, valid

P03.20	Name	In-position signal establishment time			Related mode	P
	Setting range	0~65535	Unit	1ms	Factory setting	10

It is used to set the establishment time for the in-position signal output to change from invalid to valid state. After the drive has passed the delay time set by P03.21, if the position command error is less than the setting value of positioning accuracy P03.22, and the time set by P03.20 is maintained, the driver will output an in-position completion signal.

P03.21	Name	Unit of positioning completion threshold			Related mode	P
	Setting range	0~1	Unit	-	Factory setting	1

Unit used to set the value of the positioning completion threshold P03.22 (the default value is different under each drive model, the default value is 0 under EtherCAT/CANopen, and the default value is 1 under the pulse model).

0: Command Unit

1: Encoder Unit

P03.22	Name	Positioning completion threshold			Related mode	P
	Setting range	1~65535	Unit	Encoder unit	Factory setting	10

Set the threshold of the absolute value of the position deviation when the servo driver outputs the positioning completion signal.

P03.23	Name	Clear position deviation action selection			Related mode	P
	Setting range	0~1	Unit	-	Factory setting	0

Set the clear mode of position deviation when servo enable is OFF.

Set value	Clear position deviation mode
0	Servo enable OFF, clear position deviation
1	Servo enable OFF,do not clear position deviation

P03.24	Name	Position deviation fault detection prohibited			Related mode	P
	Setting range	0: Enable position deviation fault detection 1: Disable position deviation fault detection	Unit	-	Factory setting	0

P03.25 P03.26	Name	Position deviation fault detection threshold			Related mode	P
	Setting range	1~1073741824	Unit	Encoder unit	Factory setting	1310720

Set the fault threshold for excessive position deviation in position control mode. When the position deviation of the servo motor is greater than the threshold, the servo drive will generate AL.240 (excessive position deviation). P03.25 and P03.26 are combined into a 32-bit value, where P03.25 is the low 16-bit value, and P03.26 is the high 16-bit value. Subsequent use P03.25 to represent the 32-bit parameter.

P03.27	Name	Reserve			Related mode	-
	Setting range	-	Unit	-	Factory setting	-

P03.28 P03.29	Name	Step operation			Related mode	P
	Setting range	-1073741824~1073741824	Unit	Command unit	Factory setting	10000

Set the position command source as the number of position commands in step operation (P03.00=00). P03.28 and P03.29 are combined into a 32-bit value, where P03.28 is the low 16-bit value, and P03.29 is the high 16-bit value. Subsequent use P03.28 to represent the 32-bit parameter. Motor displacement=P03.28×electronic gear ratio. The positive or negative of P03.28 determines the positive or negative of the motor speed.

P03.30	Name	Step operation speed			Related mode	P
	Setting range	0~6000	Unit	rpm	Factory setting	1000

Set the maximum operating speed during stepping operation.

P03.31	Name	Step operation acceleration time constant			Related mode	P
	Setting range	1~65535	Unit	ms	Factory setting	200

Set the variable speed time when the motor speed is changed from 0rpm to 1000rpm during step operation.

P03.32	Name	Step operation deceleration time constant			Related mode	P
	Setting range	1~65535	Unit	ms	Factory setting	200

Set the variable speed time when the motor speed is changed from 1000rpm to 0rpm during step operation.

P03.40	Name	Homing enable control			Related mode	P
	Setting range	0~6	Unit	-	Factory setting	1

Set the homing mode and trigger signal source.

Set value	Speed command source	Remark	
		Homing mode	Trigger signal
0	Close the homing	Prohibit homing	None
1	Input the "homing start" signal through the IN terminal to enable the origin homing	Origin homing	IN signal FunIN.22 (homing start)
2	Input the "homing start" signal through the IN terminal to enable the electrical homing	Electrical homing	IN signal FunIN.22 (homing start)
3	Start the origin homing immediately after power-on	Origin homing	The drive is powered on and enabled for the first time
4	Star origin homing immediately	Origin homing	The drive is enabled, after returning to the origin is completed, P03.40=0
5	Star electrical homing immediately	Electrical homing	The drive is enabled, after returning to the origin is completed, P03.40=0
6	Take the current position as the origin	Origin homing	The drive is enabled, after returning to the origin is completed, P03.40=0

P03.41	Name	Homing mode selection			Related mode	P
	Setting range	0~13	Unit	-	Factory setting	0

Set the motor rotation direction, deceleration point and origin when returning to the origin.

Set value	Speed command source			Remark
	Homing direction	Deceleration point	Origin	
0	Forward	Origin switch	Origin switch	Forward/reverse: consistent with the definition of P01.01 (rotation direction selection); Origin switch: IN function FunIN.23 (origin switch signal).
1	Reverse	Origin switch	Origin switch	
2	Forward	Positive limit	Positive limit	Positive limit switch: IN function FunIN.5 (positive limit signal)
3	Reverse	Negative limit	Negative limit	Negative limit switch: IN function FunIN.6 (negative limit signal)
4	Forward	Mechanical limit position	Mechanical limit position	Use the torque mode for the homing operation
5	Reverse	Mechanical limit position	Mechanical limit position	
Other	Reserve	Reserve	Reserve	Reserve

P03.42	Name	High speed search origin switch signal speed			Related mode	P
	Setting range	0~3000	Unit	rpm	Factory setting	100

Set the motor speed when the origin is back to zero and search the origin signal at high speed.

P03.43	Name	Low speed search origin switch signal speed			Related mode	P
	Setting range	0~1000	Unit	rpm	Factory setting	50

Set the motor speed when the origin is back to zero and the signal of the deceleration point is searched at low speed.

P03.44	Name	Search for the acceleration and deceleration time constant of the zero switch signal			Related mode	P
	Setting range	1~65535	Unit	ms	Factory setting	100

Set the time for the speed to change uniformly from 0rpm to 1000rpm when the origin is back to zero.

P03.45	Name	Reserve			Related mode	-
	Setting range	-	Unit	-	Factory setting	-

P03.46 P03.47	Name	Mechanical origin offset			Related mode	P
	Setting range	-1073741824~1073741824	Unit	Command pulse	Factory setting	0

Set the offset relationship between the mechanical origin and the mechanical zero when returning to the origin. Among them, P03.46 is the low 16-bit value, and P03.47 is the high 16-bit value. The two are combined into a signed 32-bit integer value. Subsequent use P03.46 to represent the 32-bit integer value.

P03.49	Name	Mechanical origin offset and limit processing method			Related mode	P
	Setting range	0~3	Unit	-	Factory setting	0

Set the offset relationship between the mechanical origin and the mechanical zero point when origin homing.

Set value	Mechanical origin offset processing method	Remark	
		Mechanical origin	Limit processing method
0	P03.46 is the coordinate after homing, when the limit is met, the homing function is triggered again and the homing is enabled to find the origin in the reverse direction.	The mechanical origin does not coincide with the mechanical zero point. After the origin homing is completed, the motor stops at the mechanical origin, and the mechanical origin coordinate is forced to P03.46.	Give the homing trigger signal again, the servo will perform the homing in the reverse direction.
1	P03.46 is the relative offset after homing. Re-trigger the homing function when the limit is met, and find the origin in the reverse direction after the homing is enabled.	The mechanical origin coincides with the mechanical zero point. After the motor locates the mechanical origin, it will continue to move the displacement set by P03.46 and then stop.	Give the homing trigger signal again, the servo will perform the origin return in the reverse direction.
2	P03.46 is the coordinate after homing, and it will automatically change in the reverse direction when it encounters a limit.	The mechanical origin does not coincide with the mechanical zero point. After the origin homing is completed, the motor stops at the mechanical origin, and the mechanical origin coordinate is forced to P03.46.	Servo automatically reverses, continue to perform homing function.
3	P03.46 is the relative offset after homing, and it will automatically change in the reverse direction when it encounters a limit.	The mechanical origin coincides with the mechanical zero point. After the motor locates the mechanical origin, it will continue to move the displacement set.	Servo automatically reverses, continue to perform homing function.

P03.50	Name	Touch stop homing time judgment threshold			Related mode	P
	Setting range	0~65535	Unit	ms	Factory setting	100

Set the time threshold for judging that the load reaches the mechanical position during the touch stop homing.

P03.51	Name	Touch stop homing speed judgment threshold			Related mode	P
	Setting range	0~1000	Unit	rpm	Factory setting	10

Set the speed threshold for judging that the load reaches the mechanical position during the touch stop homing.

P03.52	Name	Touch stop homing torque limit			Related mode	P
	Setting range	0~100	Unit	%	Factory setting	50

Set the maximum positive and negative torque limits during touch stop homing.

P03.53	Name	Communication control position command type			Related mode	P
	Setting range	0~1	Unit	-	Factory setting	0

This parameter means the position command type when the position command source is set as communication control (P03.00=4) under the position control mode (P01.00=0)

0: Incremental position mode
1: Absolute position mode

P03.54	Name	Communication control acceleration time constant			Related mode	P
	Setting range	1~65535	Unit	ms	Factory setting	100

Set the time for the motor speed to uniformly accelerate from 0rpm to 1000rpm in the communication control mode.

P03.55	Name	Communication control deceleration time constant			Related mode	P
	Setting range	1~65535	Unit	ms	Factory setting	100

Set the time for the motor speed to uniformly decelerate from 1000rpm to 0rpm in the communication control mode.

P03.56	Name	Communication control operating speed			Related mode	P
	Setting range	0~6000	Unit	rpm	Factory setting	500

Set the maximum running speed of the motor in the communication control mode.

P03.57 P03.58	Name	Communication control position command			Related mode	P
	Setting range	-1073741824~1073741824	Unit	Command unit	Factory setting	10000

Set the position command of the motor in the communication control mode. Among them, P03.57 is the low 16-bit value, and P03.58 is the high 16-bit value. The two form a 32-bit signed integer value.

- Note: In communication control mode, the upper computer triggers the operation of the motor by writing P03.58.**

7.5. Group P04: Speed Control Parameters

P04.00	Name	Speed command source selection			Related mode	S
	Setting range	0~10	Unit	-	Factory setting	0

Set the source of the speed command.

Set value	Speed command source	Command acquisition method
0	Number given	The motor running speed is set by P04.01, and the operation is triggered by the servo enable signal
1	Multi-segment position command	The multi-segment position operation mode is set by the group P10 parameters, and the operation is triggered by the servo enable signal
2	Communication control	Communication given position, speed and other parameters as well as start and stop command
3	IO control	Control the JOG forward and reverse rotation of the motor through the IN terminal input signal
4	Analog control	Control the forward and reverse rotation of the motor through the analog input voltage
5~10	Reserve	Don't set

P04.01	Name	Speed command digital given value			Related mode	S
	Setting range	-6000~6000	Unit	rpm	Factory setting	1000

Set the speed command source as the speed command value when digital setting (P04.00=0). The running acceleration time constant and deceleration time constant are set by P04.04 and P04.05.

P04.02	Name	Analog input channel settings			Related mode	S
	Setting range	0~1	Unit	-	Factory setting	0

When P04.00=4, which analog input channel needs to be used as the analog voltage source for motor speed control
0: AI1 channel
1: AI2 channel

P04.04	Name	Jog speed setting value			Related mode	S
	Setting range	0~6000	Unit	rpm	Factory setting	1000

When setting the keystroke jog function of the servo drive, set the jog speed command value. To use the keystroke jog function of the servo drive, please set the servo enable to OFF. The operation acceleration time constant and deceleration time constant are set by P04.04 and P04.05.

P04.05	Name	Speed command acceleration time constant			Related mode	S
	Setting range	1~65535	Unit	ms	Factory setting	200

Set the time for the speed to change uniformly from 0rpm to 1000rpm when P04.01 and P04.04 are in motion.

P04.06	Name	Speed command deceleration time constant			Related mode	S
	Setting range	1~65535	Unit	ms	Factory setting	200

Set the time for the speed to change uniformly from 1000rpm to 0rpm when P04.01 and P04.04 are in motion.

P04.07	Name	Zero speed clamp speed threshold			Related mode	S
	Setting range	0~3000	Unit	rpm	Factory setting	10

Set the speed threshold for the zero speed clamp operation to take effect only when the actual motor speed is lower than the set value.
Note: The host computer gives a zero speed clamp signal, and when the actual motor speed is lower than the set value, the motor is clamped at the current position.

P04.14	Name	Speed reaches the detection threshold			Related mode	-
	Setting range	0~6000	Unit	rpm	Factory setting	1000

When the filtered absolute value of the actual speed of the servo motor exceeds the threshold set by P04.14, it is considered that the actual speed of the servo motor has reached the desired value, and the servo drive can output a speed arrival signal at this time. On the contrary, if the absolute value of the actual speed of the servo motor after filtering is not greater than this value, the speed arrival signal is invalid. The judgment of the speed arrival signal is not affected by the operating state and control mode of the drive.

P04.15	Name	Reserve			Related mode	-
	Setting range	-	Unit	-	Factory setting	-
P04.16	Name	Speed mode jog forward speed			Related mode	S
	Setting range	0~6000	Unit	rpm	Factory setting	200
P04.17	Name	Speed mode jog reversal speed			Related mode	S
	Setting range	0~6000	Unit	rpm	Factory setting	200
P04.18	Name	Speed mode jog acceleration time constant			Related mode	S
	Setting range	1~65535	Unit	ms	Factory setting	100
P04.19	Name	Speed mode jog deceleration time constant			Related mode	S
	Setting range	1~65535	Unit	ms	Factory setting	100
P04.20	Name	Position mode jog forward speed			Related mode	P
	Setting range	0~6000	Unit	rpm	Factory setting	200
P04.21	Name	Position mode jog reversal speed			Related mode	P
	Setting range	0~6000	Unit	rpm	Factory setting	200
P04.22	Name	Position mode jog acceleration time constant			Related mode	P
	Setting range	1~65535	Unit	ms	Factory setting	100
P04.23	Name	Position mode jog deceleration time constant			Related mode	P
	Setting range	1~65535	Unit	ms	Factory setting	100
P04.24 P04.25	Name	Position mode fixed-length stroke			Related mode	P
	Setting range	0~1073741824	Unit	Command pulse	Factory setting	10000
P04.60 P04.61	Name	Communication control command pulse number			Related mode	S
	Setting range	0~1073741824	Unit	Command pulse	Factory setting	50000
P04.62	Name	Communication control speed			Related mode	S
	Setting range	0~6000	Unit	rpm	Factory setting	1000

P04.63	Name	Communication control acceleration time constant			Related mode	S
	Setting range	1~65535	Unit	ms	Factory setting	200
Set the time for the speed to change uniformly from 0rpm to 1000rpm in internal test.						

P04.64	Name	Communication control deceleration time constant			Related mode	S
	Setting range	1~65535	Unit	ms	Factory setting	200
Set the time for the speed to change uniformly from 1000rpm to 0rpm in internal test.						

P04.65	Name	Communication control running mode			Related mode	S
	Setting range	0~1	Unit	-	Factory setting	0
Set the running mode of the internal test run.						
		Set value	Running mode			
		0	Motor reciprocating			
		1	Motor runs in one direction			

P04.66	Name	Communication control initial running direction			Related mode	S
	Setting range	0~1	Unit	-	Factory setting	0
Set the initial running direction of the internal test run.						
		Set value	Starting direction			
		0	Positive direction			
		1	Negative direction			

P04.67	Name	Communication control running times			Related mode	S
	Setting range	0~65535	Unit	-	Factory setting	0
Set the running times of the communication control running. In the reciprocating running mode, the motor reciprocates completely once, and the number of runs is counted once. In unidirectional running mode, the motor stops after running and counts the number of runs.						
		Set value	Starting direction			
		0	Unlimited times			
		1~65535	Run the set number of times			

P04.68	Name	Open loop running speed			Related mode	-
	Setting range	0~3000	Unit	rpm	Factory setting	100

P04.69	Name	Open loop running acceleration			Related mode	-
	Setting range	1~100	Unit	r/s ²	Factory setting	10

P04.70	Name	Open loop running deceleration			Related mode	-
	Setting range	1~100	Unit	r/s ²	Factory setting	10

P04.71	Name	Open loop running torque			Related mode	-
	Setting range	0~100	Unit	%	Factory setting	50

P04.72	Name	Open loop running start-stop command			Related mode	-
	Setting range	0~6	Unit	-	Factory setting	0

Set the start-stop command for motor open loop operation.

Set value	Start-stop command
0	Read: The motor is in a waiting state/in a running state Write: No effect
3	Open loop forward
4	Open loop reversal
6	Deceleration stop
Other	Invalid

P04.73	Name	Lock shaft position			Related mode	-
	Setting range	0~65535	Unit	-	Factory setting	0

P04.74	Name	Lock shaft torque			Related mode	-
	Setting range	0~100	Unit	%	Factory setting	50

P04.75	Name	Lock shaft start-stop command			Related mode	-
	Setting range	0~1	Unit	-	Factory setting	0

P04.76	Name	Encoder calibration speed			Related mode	-
	Setting range	1~100	Unit	rpm	Factory setting	10

P04.77	Name	Encoder calibration acceleration			Related mode	-
	Setting range	1~10	Unit	r/s ²	Factory setting	1

P04.78	Name	Encoder calibration deceleration			Related mode	-
	Setting range	1~10	Unit	r/s ²	Factory setting	1

When setting the internal test, the motor speed is changed uniformly from 1000rpm to 0rpm.

P04.79	Name	Encoder calibration torque			Related mode	-
	Setting range	0~100	Unit	%	Factory setting	85

P04.80	Name	Encoder calibration start command			Related mode	-
	Setting range	0~2	Unit	%	Factory setting	0

P04.81	Name	Encoder receiving insufficient data fault counter			Related mode	Display
	Setting range	-	Unit	-	Factory setting	-

P04.82	Name	Encoder receiving disconnection fault counter			Related mode	Display
	Setting range	-	Unit	-	Factory setting	-

P04.83	Name	Encoder receiving CRC fault counter			Related mode	Display
	Setting range	-	Unit	-	Factory setting	-

P04.84	Name	Encoder receiving module fault counter			Related mode	Display
	Setting range	-	Unit	-	Factory setting	-

P04.85	Name	Encoder receiving continuous fault counter			Related mode	Display
	Setting range	-	Unit	-	Factory setting	-

7.6. Group P05: Torque Control Parameters

P05.00	Name	Torque command source A			Related mode	T
	Setting range	0~2	Unit	-	Factory setting	0

Set the command source of torque command source A.

Set value	Torque command source
0	Digital setting (P05.03)
1	Analog channel AI1
2	Analog channel AI2

P05.01	Name	Torque command source B			Related mode	T
	Setting range	0~2	Unit	-	Factory setting	0

Set the command source of torque command source B.

Set value	Torque command source
0	Digital setting (P05.03)
1	Analog channel AI1
2	Analog channel AI2

P05.02	Name	Torque command source			Related mode	T
	Setting range	0~3	Unit	-	Factory setting	0

Set the source of torque command

Set value	Torque command source
0	Command source A
1	Command source B
2	Communication command Source (P05.20)
3	Command source A or B

P05.03	Name	Torque command digital set value			Related mode	T
	Setting range	-3000~3000	Unit	0.1%	Factory setting	200
Set the torque command value when the torque command source is digital setting (P05.00=0). 100% corresponds to 1 times the rated torque of the motor						

P05.04	Name	Drive overload factor			Related mode	T
	Setting range	0~3000	Unit	0.1%	Factory setting	3000
Set the maximum torque command of the servo drive. 100% corresponds to 1 times the rated torque of the motor.						

P05.05	Name	Torque ramp			Related mode	T
	Setting range	1~65535	Unit	0.1%/s	Factory setting	3000
Set the increment of the torque command. A setting value of 3000 means that the torque command is evenly increased by 300% of the rated torque within 1s.						

P05.06	Name	Torque limit source (reserved)			Related mode	T
	Setting range	0~4	Unit	-	Factory setting	0

P05.07	Name	Torque limit source AI channel (reserved)			Related mode	T
	Setting range	0~1	Unit	-	Factory setting	0

P05.08	Name	Internal forward torque limit (reserved)			Related mode	T
	Setting range	0~3000	Unit	0.1%	Factory setting	3000

P05.09	Name	Internal negative torque limit (reserved)			Related mode	T
	Setting range	0~3000	Unit	0.1%	Factory setting	3000

P05.10	Name	External forward torque limit (reserved)			Related mode	T
	Setting range	0~3000	Unit	0.1%	Factory setting	3000

P05.11	Name	External negative torque limit (reserved)			Related mode	T
	Setting range	0~3000	Unit	0.1%	Factory setting	3000

P05.12	Name	Speed limit source			Related mode	T
	Setting range	0~1	Unit	-	Factory setting	0
Set the source of speed limit in torque mode: 0: Internal setting (P05.14/P05.15) 1: External analog quantity (reserved)						

P05.13	Name	Speed limit analog channel source (reserved)			Related mode	T
	Setting range	0~1	Unit	-	Factory setting	0

P05.14	Name	Torque control forward speed limit value			Related mode	T
	Setting range	0~6000	Unit	rpm	Factory setting	3000

Set the forward speed limit value in torque control mode.

P05.15	Name	Torque control negative speed limit value			Related mode	T
	Setting range	0~6000	Unit	rpm	Factory setting	3000

Set the reverse speed limit value in torque control mode.

P05.16	Name	Torque reaches the reference value			Related mode	T
	Setting range	0~65535	Unit	0.1%	Factory setting	0

P05.17	Name	Torque reaches the valid value			Related mode	T
	Setting range	0~65535	Unit	0.1%	Factory setting	100

P05.18	Name	Torque reaches the invalid value			Related mode	T
	Setting range	0~65535	Unit	0.1%	Factory setting	50

P05.19	Name	Torque reaches signal valid detection time			Related mode	T
	Setting range	0~65535	Unit	ms	Factory setting	50

P05.20	Name	Communication given torque command			Related mode	T
	Setting range	0~3000	Unit	0.1%	Factory setting	200

P05.21	Name	Torque running acceleration time constant			Related mode	T
	Setting range	1~65535	Unit	ms	Factory setting	100

It takes effect when P05.26 is set to 1, and it is another processing method for torque mode. The set value is expressed as the time for the motor speed to uniformly accelerate from 0 rpm to 1000 rpm.

P05.22	Name	Torque running deceleration time constant			Related mode	T
	Setting range	1~65535	Unit	ms	Factory setting	100

It takes effect when P05.26 is set to 1, and it is another processing method for torque mode. The set value is expressed as the time for the motor speed to decelerate uniformly from 1000 rpm to 0 rpm.

P05.23	Name	Torque holding time			Related mode	T
	Setting range	0~65535	Unit	ms	Factory setting	500

It takes effect when P05.26 is set to 1, and it is another processing method for torque mode. The set value indicates that after the torque is reached and maintained for the set time, the state of the motor shaft will be transformed into a position-locked shaft or a free state according to the set value of P05.24.

0: Keep running in torque mode until the upper computer gives a torque stop signal

Others: switch the running state after the torque is maintained for the set time

P05.24	Name	Working mode after torque is reached			Related mode	T
	Setting range	0~3	Unit	-	Factory setting	0

It takes effect when P05.26 is set to 1, and it is another processing method for torque mode. The set value indicates that after the torque reaches and maintains the setting time of P05.23, the state of the motor shaft will be transformed into a position-locked shaft or a free state according to the set value of P05.24.

0: Free state (0 torque output state)

Other: No other processing

P05.25	Name	Communication triggers torque operation			Related mode	T
	Setting range	0~2	Unit	-	Factory setting	0

It takes effect when P05.26 is set to 1, and it is another processing method for torque mode.

0: Stop

1: Forward rotation start

2: Reversal start

P05.26	Name	Torque mode operation mode selection			Related mode	T
	Setting range	0~1	Unit	-	Factory setting	0

P05.33	Name	Torque limit detection time (reserved)			Related mode	T
	Setting range	0~65535	Unit	-	Factory setting	0

P05.34	Name	Reserved			Related mode	T
	Setting range	-	Unit	-	Factory setting	-

P05.35	Name	Reserved			Related mode	T
	Setting range	-	Unit	-	Factory setting	-

P05.36	Name	Reserved			Related mode	T
	Setting range	-	Unit	-	Factory setting	-

P05.37	Name	Reserved			Related mode	T
	Setting range	-	Unit	-	Factory setting	-

7.7. Group P06: Gain Parameters

P06.00	Name	1st speed loop gain			Related mode	-
	Setting range	0~65535	Unit	0.1Hz	Factory setting	4500
<p>Set the proportional gain of the speed regulator. This parameter determines the response of the speed regulator. The larger the value, the faster the speed response. However, too large a value may cause vibration.</p> <p>In position mode, if the position gain is increased, the speed gain must be increased.</p>						

P06.01	Name	1st speed loop integral time constant			Related mode	-
	Setting range	1~30000	Unit	0.1ms	Factory setting	3500
<p>Set the integral time constant of the speed regulator. The smaller the set value, the stronger the integral effect, and the faster the speed deviation when stopping is close to zero.</p> <ul style="list-style-type: none"> Note: When P06.01 is set to 30000, there is no integral effect 						

P06.02	Name	1st position loop gain			Related mode	-
	Setting range	0~5000	Unit	0.1Hz	Factory setting	500
<p>Set the proportional gain of the position. This parameter determines the response performance of the position. Setting a larger position gain can shorten the positioning time. But too large a set value may cause mechanical vibration.</p>						

P06.03	Name	2nd speed loop gain			Related mode	-
	Setting range	0~65535	Unit	0.1Hz	Factory setting	4500

P06.04	Name	2nd speed loop integral time constant			Related mode	-
	Setting range	1~30000	Unit	0.1ms	Factory setting	3500

P06.05	Name	2nd position gain			Related mode	-
	Setting range	0~5000	Unit	0.1Hz	Factory setting	500

P06.06	Name	Skd			Related mode	-
	Setting range	0~65535	Unit	-	Factory setting	0

P06.07	Name	Skr			Related mode	-
	Setting range	0~65535	Unit	-	Factory setting	1000

P06.08	Name	Skm			Related mode	-
	Setting range	0~65535	Unit	-	Factory setting	0

P06.09	Name	Pki			Related mode	-
	Setting range	0~65535	Unit	-	Factory setting	0

P06.10	Name	Pkd			Related mode	-
	Setting range	0~65535	Unit	-	Factory setting	0

P06.14	Name	Speed feedforward low-pass filter cut-off frequency			Related mode	-
	Setting range	1~10000	Unit	Hz	Factory setting	2000

Set the filter cut-off frequency of the speed feedforward.

P06.15	Name	speed feedforward gain			Related mode	-
	Setting range	1~1000	Unit	0.1%	Factory setting	0

In the position control mode, multiply the speed feedforward signal by the parameter P06.15, and the result obtained becomes the speed feedforward as part of the speed command. Increasing this parameter can increase the response speed of the position command and reduce the position deviation at a fixed speed.

P06.16	Name	Torque feedforward low-pass filter cut-off frequency			Related mode	-
	Setting range	1~10000	Unit	Hz	Factory setting	2000

Set the filter frequency of the torque feedforward.

P06.17	Name	Torque feedforward gain			Related mode	-
	Setting range	0~1000	Unit	0.1%	Factory setting	0

In the non-torque control mode, multiply the torque feedforward signal by the parameter P06.17, and the result obtained becomes the torque feedforward as part of the torque command. Increasing this parameter can improve the response speed to changing speed commands.

P06.18	Name	Reserved			Related mode	-
	Setting range	-	Unit	-	Factory setting	-

P06.19	Name	Speed low-pass filter cut-off frequency 1			Related mode	-
	Setting range	1~10000	Unit	Hz	Factory setting	1000

Set the cut-off frequency 1 for the low-pass filter of the speed feedback value. The smaller the setting, the smaller the speed feedback fluctuation, but the larger the feedback delay.

P06.20	Name	Speed low-pass filter cut-off frequency 2			Related mode	-
	Setting range	1~10000	Unit	Hz	Factory setting	2000

P06.21	Name	Reserved			Related mode	-
	Setting range	-	Unit	-	Factory setting	-

P06.24	Name	Torque command low-pass filter cut-off frequency 1			Related mode	-
	Setting range	1~10000	Unit	Hz	Factory setting	1000

Set the torque command low-pass filter cut-off frequency. Filtering the torque command can make the torque command smoother and reduce vibration. If the filter cutoff frequency setting value is too small, the responsiveness will be reduced. Set it while confirming the responsiveness.

P06.25	Name	Reserved			Related mode	-
	Setting range	-	Unit	-	Factory setting	-

P06.26	Name	Torque feedback low-pass filter cut-off frequency 1			Related mode	-
	Setting range	1~10000	Unit	Hz	Factory setting	1000
Set the torque feedback low-pass filter cut-off frequency. Through the low-pass filtering of the torque feedback, the torque feedback can be made smoother and vibration can be reduced. If the set value of the filter cutoff frequency constant is too small, the responsiveness will be reduced. Set it while confirming the responsiveness.						

P06.27	Name	Reserved			Related mode	-
	Setting range	-	Unit	-	Factory setting	-

P06.28	Name	Current loop proportional gain			Related mode	-
	Setting range	1~50000	Unit	Hz	Factory setting	1000

P06.29	Name	Current loop integral time constant			Related mode	-
	Setting range	1~10000	Unit	0.1ms	Factory setting	1500
Set the integral time constant of the torque loop. The smaller the setting value, the faster the integration speed and the smaller the current tracking error. However, if the integration is too small, oscillation or noise will easily occur. When the set value is 10000, the integrator does not work.						

P06.30	Name	PVIA proportional gain KP			Related mode	-
	Setting range	0~50000	Unit	-	Factory setting	3000

P06.31	Name	PVIA integral gain KI			Related mode	-
	Setting range	0~10000	Unit	-	Factory setting	1000

P06.32	Name	PVIA speed gain KV1			Related mode	-
	Setting range	0~50000	Unit	-	Factory setting	1000

P06.33	Name	PVIA speed gain KV2			Related mode	-
	Setting range	0~50000	Unit	-	Factory setting	100

P06.34	Name	PVIA acceleration gain KA			Related mode	-
	Setting range	0~50000	Unit	-	Factory setting	0

P06.35	Name	PVIA speed gain KVFF			Related mode	-
	Setting range	0~50000	Unit	-	Factory setting	1000

P06.36	Name	PVIA acceleration gain KAFF			Related mode	-
	Setting range	0~50000	Unit	-	Factory setting	0

P06.37	Name	PVIA command speed low-pass filter cut-off frequency			Related mode	-
	Setting range	0~10000	Unit	-	Factory setting	1000

P06.38	Name	PVIA command acceleration low-pass filter cut-off frequency			Related mode	-
	Setting range	0~10000	Unit	-	Factory setting	2000
P06.39	Name	PVIA feedback acceleration low-pass filter cut-off frequency			Related mode	-
	Setting range	0~10000	Unit	-	Factory setting	2000
P06.40	Name	PVIA enable control			Related mode	-
	Setting range	0: Use the three-loop control algorithm. 1: Use PVIA control algorithm.		Unit	-	Factory setting 0
P06.45	Name	Reserved			Related mode	-
	Setting range	-	Unit	-	Factory setting	-
P06.46	Name	Reserved			Related mode	-
	Setting range	-	Unit	-	Factory setting	-
P06.47	Name	Reserved			Related mode	-
	Setting range	-	Unit	-	Factory setting	-
P06.48	Name	Reserved			Related mode	-
	Setting range	-	Unit	-	Factory setting	-
P06.49	Name	Reserved			Related mode	-
	Setting range	-	Unit	-	Factory setting	-
P06.50	Name	Reserved			Related mode	-
	Setting range	-	Unit	-	Factory setting	-
P06.51	Name	Reserved			Related mode	-
	Setting range	-	Unit	-	Factory setting	-
P06.52	Name	Reserved			Related mode	-
	Setting range	-	Unit	-	Factory setting	-
P06.53	Name	Reserved			Related mode	-
	Setting range	-	Unit	-	Factory setting	-

7.8. Group P08: Communication Parameters

P08.00	Name	RS485 communication axis address			Related mode	-
	Setting range	1~247	Unit	-	Factory setting	1

Set the servo drive axis address.

0: broadcast address. The upper computer device can write to all servo drives through the broadcast address. The drive operates according to the broadcast data frame, but does not respond.

1 ~ 247: when multiple servo drives are networking, each servo drive can only have a unique address, otherwise it will lead to abnormal communication or failure of communication.

P08.01	Name	RS485 communication baud rate selection			Related mode	-
	Setting range	0~5	Unit	-	Factory setting	5

Set the communication baud rate between the servo driver and the upper computer device. The communication baud rate of the servo driver must be consistent with the communication baud rate of the upper computer device, otherwise it cannot communicate.

Set value	Baud rate setting
0	4800 Kbps
1	9600 Kbps
2	19200 Kbps
3	38400 Kbps
4	57600 Kbps
5	115200 Kbps

P08.02	Name	RS485 communication data format selection			Related mode	-
	Setting range	0~5	Unit	-	Factory setting	0

Set the data format when the servo driver communicates with the upper computer device. The data format of servo driver must be consistent with the upper computer device, otherwise it cannot communicate.

Set value	Data Format
0	8-bit data, no parity, 1 stop bit
1	8-bit data, no parity, 2 stop bits
2	8-bit data, even parity, 1 stop bit
3	8-bit data, even parity, 2 stop bits
4	8-bit data, odd parity, 1 stop bit
5	8-bit data, odd parity, 2 stop bits

P08.05	Name	CAN communication axis address			Related mode	-
	Setting range	1~127	Unit	-	Factory setting	2

Set the CAN communication address of servo drive.

1 ~ 127: when multiple servo drives are networking, each servo drive can only have a unique address, otherwise it will lead to abnormal communication or failure of communication.

P08.06	Name	CAN communication baud rate selection			Related mode	-
	Setting range	0~6	Unit	-	Factory setting	4

Set the communication baud rate between the servo drive and the upper computer device. The communication baud rate of the servo drive must be consistent with the communication baud rate of the upper computer device, otherwise it cannot communicate.

Set value	Baud rate setting
0	20 Kbps
1	50 Kbps
2	100 Kbps
3	125 Kbps
4	250 Kbps
5	500 Kbps
6	1000 Kbps

P08.07	Name	CAN disconnection detection time			Related mode	-
	Setting range	0~65535	Unit	ms	Factory setting	0

Set the detection time of CAN communication interruption. If no CANopen synchronization signal is received within the set time, CAN communication disconnection fault will be reported.

0: disconnection detection is disabled

Other values: delay time of disconnection detection

P08.08	Name	Site address assigned by EtherCAT host			Related mode	-
	Setting range	Display	Unit	-	Factory setting	-

P08.09	Name	Display the current site alias address of the drive			Related mode	-
	Setting range	Display	Unit	-	Factory setting	-

P08.10	Name	Set the EtherCAT communication station of the drive			Related mode	-
	Setting range	0~65535	Unit	-	Factory setting	0

When the host cannot automatically assign the servo drive site address, you can manually assign a site address to the drive in this way.

0: the site address is not assigned manually. The site address is assigned by the host or written to EEPROM.

Other values: manually assign a station address. After the drive is powered on and initialized, the value of p08.08 will be consistent with the set value.

Note: this operation is only to write the site alias register of the ESC slave controller chip of EtherCAT. As for whether to actually enable the site address as the addressing address of the servo drive, the host needs to carry out corresponding operations.

P08.30	Name	RS232 communication axis address			Related mode	-
	Setting range	-	Unit	-	Factory setting	1

P08.31	Name	RS232 communication serial port baud rate selection			Related mode	-
	Setting range	0~5	Unit	-	Factory setting	5

Set the RS232 communication baud rate, please refer to parameter P08.01 (RS485 communication data format selection) for the setting method.

P08.32	Name	RS232 communication data format selection			Related mode	-
	Setting range	0~5	Unit	-	Factory setting	0

Set the RS232 communication data format, please refer to parameter P08.02 (RS485 communication data format selection) for the setting method.

7.9. Group P09: Multi-segment Position Parameters

P09.00	Name	Multi-segment position operation mode			Related mode	P
	Setting range	0~2	Unit	-	Factory setting	1

In the position control mode, when the source of the set position command is multi-stage position command (p03.00 = 2), set the multi-stage position operation mode.

Set value	Operation mode	Remark	Operating waveform
0	Shutdown at the end of a single operation	<p>Stop after running for 1 round;</p> <p>The segment number is automatically switched in increasing order;</p> <p>Waiting time can be set between segments;</p> <p>Multi-segment position enable is level effective;</p>	<p>V_{1max}、V_{2max}: maximum operating speed of the first and second segments;</p> <p>S1、S2: displacement of the first and second segments;</p>
1	Cyclic operation	<p>Cycle operation, the starting segment number after the first round is 1;</p> <p>The segment number is automatically switched in increasing order;</p> <p>Waiting time can be set between segments;</p> <p>Multi-segment position enable is level effective;</p>	<p>V_{1max}、V_{2max}: maximum operating speed of the first and second segments;</p> <p>S1、S2: displacement of the first and second segments;</p>

2	IN switching operation	<p>If the segment number is updated, it can run continuously;</p> <p>The segment number is determined by IN terminal logic;</p> <p>The interval between segments is determined by the command delay time of the host computer;</p> <p>Multi-segment position enable is effective for edge change;</p>	<p>可用于设置 y 段段号的时间区域: It can be used to set the time zone of the y segment number.</p> <p>V_{xmax}、V_{ymax}: maximum operating speed of the x and y segments;</p> <p>S1、S2: displacement of the x and y segments;</p>
---	------------------------	---	--

P09.01	Name	Number of terminal segments of position command			Related mode	P																																		
	Setting range	1~16	Unit	-	Factory setting	1																																		
<p>Set the total number of segments of the multi-segment position command. Different segments can set different displacement, running speed, acceleration and deceleration.</p> <p>When P09.00 = 0/1, the multi-segment segment number will automatically increase and switch, and the switching sequence: 1, 2, 3,..., P09.01</p> <p>When P09.01 = 2, 4 INs should be set as input functions FunIN.14~FunIN.17 (multi-stage running command switching 1: CMD1~multi-stage running command switching 4: CMD4), and the logic of the IN terminal is controlled by the upper computer to achieve Segment number switching. The multi-segment segment number is a 4-digit binary number, and the corresponding relationship between CMD1 ~ CMD4 and the segment number is shown below.</p> <table border="1" style="margin-left: auto; margin-right: auto;"> <thead> <tr> <th>FunIN.17</th> <th>FunIN.16</th> <th>FunIN.15</th> <th>FunIN.14</th> <th rowspan="2">segment number</th> </tr> <tr> <th>CMD4</th> <th>CMD3</th> <th>CMD2</th> <th>CMD1</th> </tr> </thead> <tbody> <tr> <td style="text-align: center;">0</td> <td style="text-align: center;">0</td> <td style="text-align: center;">0</td> <td style="text-align: center;">0</td> <td style="text-align: center;">1</td> </tr> <tr> <td style="text-align: center;">0</td> <td style="text-align: center;">0</td> <td style="text-align: center;">0</td> <td style="text-align: center;">1</td> <td style="text-align: center;">2</td> </tr> <tr> <td colspan="5" style="text-align: center;">.....</td> </tr> <tr> <td style="text-align: center;">1</td> <td style="text-align: center;">1</td> <td style="text-align: center;">1</td> <td style="text-align: center;">0</td> <td style="text-align: center;">15</td> </tr> <tr> <td style="text-align: center;">1</td> <td style="text-align: center;">1</td> <td style="text-align: center;">1</td> <td style="text-align: center;">1</td> <td style="text-align: center;">16</td> </tr> </tbody> </table> <p>The value of CMD(n) is 1 when the IN terminal logic is valid, otherwise it is 0.</p>							FunIN.17	FunIN.16	FunIN.15	FunIN.14	segment number	CMD4	CMD3	CMD2	CMD1	0	0	0	0	1	0	0	0	1	2					1	1	1	0	15	1	1	1	1	16
FunIN.17	FunIN.16	FunIN.15	FunIN.14	segment number																																				
CMD4	CMD3	CMD2	CMD1																																					
0	0	0	0	1																																				
0	0	0	1	2																																				
.....																																								
1	1	1	0	15																																				
1	1	1	1	16																																				

P09.03	Name	Time unit selection			Related mode	P						
	Setting range	0~1	Unit	-	Factory setting	0						
<p>When the multi segment position function is used for operation and p09.00 = 0 / 1 is set, the unit of waiting time between segments is set.</p> <p>Waiting time: the time interval from the end of this command to the beginning of the next command.</p> <table border="1" style="margin-left: auto; margin-right: auto;"> <thead> <tr> <th>Set value</th> <th>Time Unit</th> </tr> </thead> <tbody> <tr> <td style="text-align: center;">0</td> <td style="text-align: center;">ms</td> </tr> <tr> <td style="text-align: center;">1</td> <td style="text-align: center;">s</td> </tr> </tbody> </table>							Set value	Time Unit	0	ms	1	s
Set value	Time Unit											
0	ms											
1	s											

P09.04	Name	Position command type selection			Related mode	P
	Setting range	0~1	Unit	-	Factory setting	0

When using the multi-segment position function to run, set the type of displacement command.

Displacement command: the sum of position commands in a period of time.

The relative displacement is the increment of the target position relative to the current position of the motor; the absolute displacement is the increment of the target position relative to the motor origin. For example: the movement displacement of the nth segment is P_n ($P_n > 0$), and the movement displacement of the mth segment is P_m ($P_m > 0$). Assuming $P_m > P_n$, the comparison is as follows:

Set value	Position command type	Remark
0	Relative displacement command	
1	Absolute displacement command	

P09.12 P09.13	Name	Segment 1 position command			Related mode	P
	Setting range	-1073741824~1073741824	Unit	Command unit	Factory setting	10000

Multi segment position first segment movement displacement (command unit). P09.12 and p09.13 are combined into a 32-bit signed value, where p09.12 is the low 16 bit value and p09.13 is the high 16 bit value. Subsequently, p09.12 is used to represent this 32-bit parameter.

P09.14	Name	Segment 1 maximum running speed			Related mode	P
	Setting range	1~6000	Unit	rpm	Factory setting	200

Maximum operating speed of the first segment at multi segment position. The maximum running speed refers to the uniform running speed at which the motor is not in the acceleration and deceleration process. If the 1st position command (p09.12) is too small, the actual speed of the motor will be less than p09.14.

P09.15	Name	Segment 1 position command acceleration and deceleration time constant			Related mode	P
	Setting range	1~65535	Unit	ms	Factory setting	100
In the first stage of multi-segment position, the time of the motor from 0rpm uniform speed to 1000rpm.						

P09.16	Name	Waiting time after the completion of segment 1 position command			Related mode	P
	Setting range	0~65535	Unit	ms(s)	Factory setting	100
After the first stage of the multi-segment position is completed, the waiting time before running the next stage of displacement.						

P09.17	Name	Segment 2 position command			Related mode	P
P09.18	Setting range	-1073741824~1073741824	Unit	Command unit	Factory setting	10000

P09.19	Name	Segment 2 maximum running speed			Related mode	P
	Setting range	1~6000	Unit	rpm	Factory setting	200

P09.20	Name	Segment 2 position command acceleration and deceleration time constant			Related mode	P
	Setting range	1~65535	Unit	ms	Factory setting	100

P09.21	Name	Waiting time after the completion of segment 2 position command			Related mode	P
	Setting range	0~65535	Unit	ms(s)	Factory setting	100

P09.22	Name	Segment 3 position command			Related mode	P
P09.23	Setting range	-1073741824~1073741824	Unit	Command unit	Factory setting	10000

P09.24	Name	Segment 3 maximum running speed			Related mode	P
	Setting range	1~6000	Unit	rpm	Factory setting	200

P09.25	Name	Segment 3 position command acceleration and deceleration time constant			Related mode	P
	Setting range	1~65535	Unit	ms	Factory setting	100

P09.26	Name	Waiting time after the completion of segment 3 position command			Related mode	P
	Setting range	0~65535	Unit	ms(s)	Factory setting	100

P09.27	Name	Segment 4 position command			Related mode	P
P09.28	Setting range	-1073741824~1073741824	Unit	Command unit	Factory setting	10000

P09.29	Name	Segment 4 maximum running speed			Related mode	P
	Setting range	1~6000	Unit	rpm	Factory setting	200

P09.30	Name	Segment 4 position command acceleration and deceleration time constant			Related mode	P
	Setting range	1~65535	Unit	ms	Factory setting	100
P09.31	Name	Waiting time after the completion of segment 4 position command			Related mode	P
	Setting range	0~65535	Unit	ms(s)	Factory setting	100
P09.32 P09.33	Name	Segment 5 position command			Related mode	P
	Setting range	-1073741824~1073741824	Unit	Command unit	Factory setting	10000
P09.34	Name	Segment 5 maximum running speed			Related mode	P
	Setting range	1~6000	Unit	rpm	Factory setting	200
P09.35	Name	Segment 5 position command acceleration and deceleration time constant			Related mode	P
	Setting range	1~65535	Unit	ms	Factory setting	100
P09.36	Name	Waiting time after the completion of segment 5 position command			Related mode	P
	Setting range	0~65535	Unit	ms(s)	Factory setting	100
P09.37 P09.38	Name	Segment 6 position command			Related mode	P
	Setting range	-1073741824~1073741824	Unit	Command unit	Factory setting	10000
P09.39	Name	Segment 6 maximum running speed			Related mode	P
	Setting range	1~6000	Unit	rpm	Factory setting	200
P09.40	Name	Segment 6 position command acceleration and deceleration time constant			Related mode	P
	Setting range	1~65535	Unit	ms	Factory setting	100
P09.41	Name	Waiting time after the completion of segment 6 position command			Related mode	P
	Setting range	0~65535	Unit	ms(s)	Factory setting	100
P09.42 P09.43	Name	Segment 7 position command			Related mode	P
	Setting range	-1073741824~1073741824	Unit	Command unit	Factory setting	10000
P09.44	Name	Segment 7 maximum running speed			Related mode	P
	Setting range	1~6000	Unit	rpm	Factory setting	200

P09.45	Name	Segment 7 position command acceleration and deceleration time constant			Related mode	P
	Setting range	1~65535	Unit	ms	Factory setting	100
P09.46	Name	Waiting time after the completion of segment 7 position command			Related mode	P
	Setting range	0~65535	Unit	ms(s)	Factory setting	100
P09.47 P09.48	Name	Segment 8 position command			Related mode	P
	Setting range	-1073741824~1073741824	Unit	Command unit	Factory setting	10000
P09.49	Name	Segment 8 maximum running speed			Related mode	P
	Setting range	1~6000	Unit	rpm	Factory setting	200
P09.50	Name	Segment 8 position command acceleration and deceleration time constant			Related mode	P
	Setting range	1~65535	Unit	ms	Factory setting	100
P09.51	Name	Waiting time after the completion of segment 8 position command			Related mode	P
	Setting range	0~65535	Unit	ms(s)	Factory setting	100
P09.52 P09.53	Name	Segment 9 position command			Related mode	P
	Setting range	-1073741824~1073741824	Unit	Command unit	Factory setting	10000
P09.54	Name	Segment 9 maximum running speed			Related mode	P
	Setting range	1~6000	Unit	rpm	Factory setting	200
P09.55	Name	Segment 9 position command acceleration and deceleration time constant			Related mode	P
	Setting range	1~65535	Unit	ms	Factory setting	100
P09.56	Name	Waiting time after the completion of segment 9 position command			Related mode	P
	Setting range	0~65535	Unit	ms(s)	Factory setting	100
P09.57 P09.58	Name	Segment 10 position command			Related mode	P
	Setting range	-1073741824~1073741824	Unit	Command unit	Factory setting	10000
P09.59	Name	Segment 10 maximum running speed			Related mode	P
	Setting range	1~6000	Unit	rpm	Factory setting	200
P09.60	Name	Segment 10 position command acceleration and deceleration time constant			Related mode	P
	Setting range	1~65535	Unit	ms	Factory setting	100

P09.61	Name	Waiting time after the completion of segment 10 position command			Related mode	P
	Setting range	0~65535	Unit	ms(s)	Factory setting	100
P09.62 P09.63	Name	Segment 11 position command			Related mode	P
	Setting range	-1073741824~1073741824	Unit	Command unit	Factory setting	10000
P09.64	Name	Segment 11 maximum running speed			Related mode	P
	Setting range	1~6000	Unit	rpm	Factory setting	200
P09.65	Name	Segment 11 position command acceleration and deceleration time constant			Related mode	P
	Setting range	1~65535	Unit	ms	Factory setting	100
P09.66	Name	Waiting time after the completion of segment 11 position command			Related mode	P
	Setting range	0~65535	Unit	ms(s)	Factory setting	100
P09.67 P09.68	Name	Segment 12 position command			Related mode	P
	Setting range	-1073741824~1073741824	Unit	Command unit	Factory setting	10000
P09.69	Name	Segment 12 maximum running speed			Related mode	P
	Setting range	1~6000	Unit	rpm	Factory setting	200
P09.70	Name	Segment 12 position command acceleration and deceleration time constant			Related mode	P
	Setting range	1~65535	Unit	ms	Factory setting	100
P09.71	Name	Waiting time after the completion of segment 12 position command			Related mode	P
	Setting range	0~65535	Unit	ms(s)	Factory setting	100
P09.72 P09.73	Name	Segment 13 position command			Related mode	P
	Setting range	-1073741824~1073741824	Unit	Command unit	Factory setting	10000
P09.74	Name	Segment 13 maximum running speed			Related mode	P
	Setting range	1~6000	Unit	rpm	Factory setting	200

P09.75	Name	Segment 13 position command acceleration and deceleration time constant			Related mode	P
	Setting range	1~65535	Unit	ms	Factory setting	100
P09.76	Name	Waiting time after the completion of segment 13 position command			Related mode	P
	Setting range	0~65535	Unit	ms(s)	Factory setting	100
P09.77 P09.78	Name	Segment 14 position command			Related mode	P
	Setting range	-1073741824~1073741824	Unit	Command unit	Factory setting	10000
P09.79	Name	Segment 14 maximum running speed			Related mode	P
	Setting range	1~6000	Unit	rpm	Factory setting	200
P09.80	Name	Segment 14 position command acceleration and deceleration time constant			Related mode	P
	Setting range	1~65535	Unit	ms	Factory setting	100
P09.81	Name	Waiting time after the completion of segment 14 position command			Related mode	P
	Setting range	0~65535	Unit	ms(s)	Factory setting	100
P09.82 P09.83	Name	Segment 15 position command			Related mode	P
	Setting range	-1073741824~1073741824	Unit	Command unit	Factory setting	10000
P09.84	Name	Segment 15 maximum running speed			Related mode	P
	Setting range	1~6000	Unit	rpm	Factory setting	200
P09.85	Name	Segment 15 position command acceleration and deceleration time constant			Related mode	P
	Setting range	1~65535	Unit	ms	Factory setting	100
P09.86	Name	Waiting time after the completion of segment 15 position command			Related mode	P
	Setting range	0~65535	Unit	ms(s)	Factory setting	100
P09.87 P09.88	Name	Segment 16 position command			Related mode	P
	Setting range	-1073741824~1073741824	Unit	Command unit	Factory setting	10000

P09.89	Name	Segment 16 maximum running speed			Related mode	P
	Setting range	1~6000	Unit	rpm	Factory setting	200

P09.90	Name	Segment 16 position command acceleration and deceleration time constant			Related mode	P
	Setting range	1~65535	Unit	ms	Factory setting	100

P09.91	Name	Waiting time after the completion of segment 16 position command			Related mode	P
	Setting range	0~65535	Unit	ms(s)	Factory setting	100

7.10. Group P10: Multi-segment Speed Parameters

P10.00	Name	Multi-segment speed command operation mode			Related mode	S
	Setting range	0~2	Unit	-	Factory setting	1

In speed control mode, when the speed command source is a multi-segment speed command (P04.00=1), set the multi-segment speed command operation mode:

Set value	Operation mode	Remark	Operating waveform
0	Shutdown at the end of a single operation	Stop after running for 1 round; The segment number is automatically switched in increasing order.	<p>V1max, V2max: the first and second command speeds; t1: the actual acceleration and deceleration time of the first segment; t3, t5: the second segment of acceleration and deceleration time.</p>
1	Cyclic operation	Cycle operation, the starting segment number of each round is 1; the segment number is automatically switched in increasing order; If the servo enable is valid, the cycle running state will always be maintained.	<p>V1max, V2max: the first and second segment maximum operating speeds.</p>

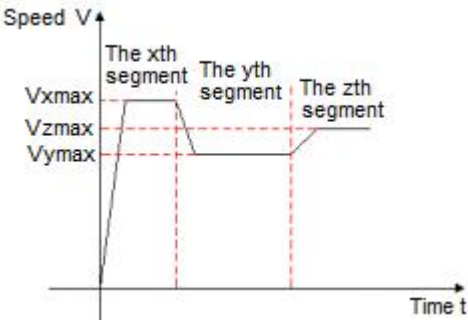
2	Switch through the external IN port	<p>If the servo is enabled, it can run continuously; The segment number is determined by the IN terminal logic; The running time of each speed command is only determined by the switching interval time of the segment number; FunIN.19 (speed command direction setting) can be used to switch the speed command direction.</p>	 <p>x, y: segment number, please refer to P10.01 for the logical relationship between segment number and IN terminal; Vx, Vy: the speed command of the xth section and the yth section; The segment number determined by IN will not change, and the speed command of this segment will continue to run without being affected by the command running time.</p>
---	-------------------------------------	--	---

During the operation of each speed command, the servo enable must be ensured, otherwise, the servo driver will stop.

P10.01	Name	Speed command end segment number			Related mode	S
	Setting range	1~16	Unit	-	Factory setting	16

Set the total number of segments of the speed command. Different segments can set different speeds and running times, and there are 7 groups of acceleration and deceleration times for selection.

When P10.00≠2, the multi-segment segment numbers are automatically switched in increasing order, the switching sequence: 1, 2, ..., P10.01.

When P10.00=2, 4 INs should be set as IN functions 14~17 (FunIN.14~FunIN.17), and the upper computer controls the IN logic to realize the segment number switching. The multi-segment segment number is a 4-digit binary number. The corresponding relationship between FunIN.14~FunIN.17 and the segment number is shown in the following table.

FunIN.17	FunIN.16	FunIN.15	FunIN.14	Segment number
0	0	0	0	1
0	0	0	1	2
0	0	1	0	3
.....				
1	1	1	1	16

When the IN terminal logic is valid, the value of FunIN.n is 1, otherwise it is 0.

P10.02	Name	Running time unit			Related mode	S
	Setting range	0~65535	Unit	-	Factory setting	0

Set multi-segment speed running time unit.

Set value	Time unit
0	sec(second)
1	min(minute)

P10.03	Name	Acceleration time constant 1			Related mode	S
	Setting range	1~65535	Unit	ms	Factory setting	200

For each multi-segment speed command, there are 7 groups of acceleration and deceleration time constants for selection.
Acceleration time constant: the time for the servo motor to uniformly accelerate from 0rpm to 1000rpm.
Deceleration time constant: the time for the servo motor to decelerate uniformly from 1000rpm to 0rpm.

P10.04	Name	Deceleration time constant 1			Related mode	S
	Setting range	1~65535	Unit	ms	Factory setting	200

P10.05	Name	Acceleration time constant 2			Related mode	S
	Setting range	1~65535	Unit	ms	Factory setting	200

P10.06	Name	Deceleration time constant 2			Related mode	S
	Setting range	1~65535	Unit	ms	Factory setting	200

P10.07	Name	Acceleration time constant 3			Related mode	S
	Setting range	1~65535	Unit	ms	Factory setting	200

P10.08	Name	Deceleration time constant 3			Related mode	S
	Setting range	1~65535	Unit	ms	Factory setting	200

P10.09	Name	Acceleration time constant 4			Related mode	S
	Setting range	1~65535	Unit	ms	Factory setting	200

P10.10	Name	Deceleration time constant 4			Related mode	S
	Setting range	1~65535	Unit	ms	Factory setting	200

P10.11	Name	Acceleration time constant 5			Related mode	S
	Setting range	1~65535	Unit	ms	Factory setting	200

P10.12	Name	Deceleration time constant 5			Related mode	S
	Setting range	1~65535	Unit	ms	Factory setting	200

P10.13	Name	Acceleration time constant 6			Related mode	S
	Setting range	1~65535	Unit	ms	Factory setting	200

P10.14	Name	Deceleration time constant 6			Related mode	S
	Setting range	1~65535	Unit	ms	Factory setting	200

P10.15	Name	Acceleration time constant7			Related mode	S
	Setting range	1~65535	Unit	ms	Factory setting	200

P10.16	Name	Deceleration time constant 7			Related mode	S
	Setting range	1~65535	Unit	ms	Factory setting	200

P10.20	Name	Segment 1 speed command			Related mode	S
	Setting range	-6000~6000	Unit	rpm	Factory setting	100

P10.21	Name	Segment 1 speed command running time			Related mode	S
	Setting range	0~65535	Unit	ms	Factory setting	10

Set the running time of the first segment speed command.

Running time: the shifting time of the previous speed command switching to this speed command + this constant speed running time.

If the running time is set to 0, the servo drive will automatically skip this speed command.

When P10.02=2, as long as the segment number determined by the external IN terminal does not change, the speed command of this segment will continue to run without being affected by the command running time.

P10.22	Name	1st segment acceleration and deceleration time constant selection			Related mode	S
	Setting range	1~7	Unit	-	Factory setting	1

Select the acceleration and deceleration time constant of the first segment speed command.

Set value	Acceleration and deceleration time constant	Remark
1	Acceleration and deceleration time constant 1	Acceleration time: P10.03 Deceleration time: P10.04
2	Acceleration and deceleration time constant 2	Acceleration time: P10.05 Deceleration time: P10.06
3	Acceleration and deceleration time constant 3	Acceleration time: P10.07 Deceleration time: P10.08
4	Acceleration and deceleration time constant 4	Acceleration time: P10.09 Deceleration time: P10.10
5	Acceleration and deceleration time constant 5	Acceleration time: P10.11 Deceleration time: P10.12
6	Acceleration and deceleration time constant 6	Acceleration time: P10.13 Deceleration time: P10.14
7	Acceleration and deceleration time constant 7	Acceleration time: P10.15 Deceleration time: P10.16

V1max, V2max: the first and second segment command speeds;

t1: the actual acceleration and deceleration time of the first segment;

t3、 t5: the actual acceleration and deceleration time of the second segment;

A certain period of running time: the shifting time of the previous speed command switching to this speed command + the constant speed running time of this section (for example: the running time of the first segment in the figure is t1+t2, and the running time of the second segment is t3+t4. And so on);

When a certain period of running time is set to 0, the driver will skip this section of speed command and execute the next section;

$$t_1 = \frac{V_1}{1000} \times \text{Acceleration time set for this speed segment}$$

$$t_3 = \frac{|V_2 - V_1|}{1000} \times \text{The acceleration time set in the second segment}$$

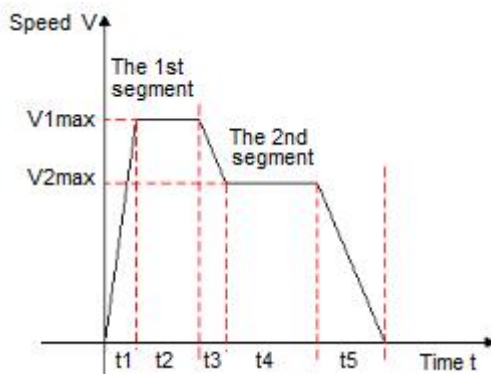

P10.23	Name	Segment 2 speed command			Related mode	S
	Setting range	-6000~6000	Unit	rpm	Factory setting	200

P10.24	Name	Segment 2 speed command running time			Related mode	S
	Setting range	0~65535	Unit	ms	Factory setting	20

P10.25	Name	Segment 2 acceleration and deceleration time constant selection			Related mode	S
	Setting range	1~7	Unit	-	Factory setting	1

P10.26	Name	Segment 3 speed command			Related mode	S
	Setting range	-6000~6000	Unit	rpm	Factory setting	300

P10.27	Name	Segment 3 speed command running time			Related mode	S
	Setting range	0~65535	Unit	ms	Factory setting	30

P10.28	Name	Segment 3 acceleration and deceleration time constant selection			Related mode	S
	Setting range	1~7	Unit	-	Factory setting	1

P10.29	Name	Segment 4 speed command			Related mode	S
	Setting range	-6000~6000	Unit	rpm	Factory setting	400

P10.30	Name	Segment 4 speed command running time			Related mode	S
	Setting range	0~65535	Unit	ms	Factory setting	40

P10.31	Name	Segment 4 acceleration and deceleration time constant selection			Related mode	S
	Setting range	1~7	Unit	-	Factory setting	1
P10.32	Name	Segment 5 speed command			Related mode	S
	Setting range	-6000~6000	Unit	rpm	Factory setting	500
P10.33	Name	Segment 5 speed command running time			Related mode	S
	Setting range	0~65535	Unit	ms	Factory setting	50
P10.34	Name	Segment 5 acceleration and deceleration time constant selection			Related mode	S
	Setting range	1~7	Unit	-	Factory setting	1
P10.35	Name	Segment 6 speed command			Related mode	S
	Setting range	-6000~6000	Unit	rpm	Factory setting	600
P10.36	Name	Segment 6 speed command running time			Related mode	S
	Setting range	0~65535	Unit	ms	Factory setting	60
P10.37	Name	Segment 6 acceleration and deceleration time constant selection			Related mode	S
	Setting range	1~7	Unit	-	Factory setting	1
P10.38	Name	Segment 7 speed command			Related mode	S
	Setting range	-6000~6000	Unit	rpm	Factory setting	700
P10.39	Name	Segment 7 speed command running time			Related mode	S
	Setting range	0~65535	Unit	ms	Factory setting	70
P10.40	Name	Segment 7 acceleration and deceleration time constant selection			Related mode	S
	Setting range	1~7	Unit	-	Factory setting	1
P10.41	Name	Segment 8 speed command			Related mode	S
	Setting range	-6000~6000	Unit	rpm	Factory setting	800
P10.42	Name	Segment 8 speed command running time			Related mode	S
	Setting range	0~65535	Unit	ms	Factory setting	80

P10.43	Name	Segment 8 acceleration and deceleration time constant selection			Related mode	S
	Setting range	1~7	Unit	-	Factory setting	1
P10.44	Name	Segment 9 speed command			Related mode	S
	Setting range	-6000~6000	Unit	rpm	Factory setting	900
P10.45	Name	Segment 9 speed command running time			Related mode	S
	Setting range	0~65535	Unit	ms	Factory setting	90
P10.46	Name	Segment 9 acceleration and deceleration time constant selection			Related mode	S
	Setting range	1~7	Unit	-	Factory setting	1
10.47	Name	Segment 10 speed command			Related mode	S
	Setting range	-6000~6000	Unit	rpm	Factory setting	1000
P10.48	Name	Segment 10 speed command running time			Related mode	S
	Setting range	0~65535	Unit	ms	Factory setting	100
P10.49	Name	Segment 10 acceleration and deceleration time constant selection			Related mode	S
	Setting range	1~7	Unit	-	Factory setting	1
P10.50	Name	Segment 11 speed command			Related mode	S
	Setting range	-6000~6000	Unit	rpm	Factory setting	1100
P10.51	Name	Segment 11 speed command running time			Related mode	S
	Setting range	0~65535	Unit	0.1sec / 0.1min	Factory setting	110
P10.52	Name	Segment 11 acceleration and deceleration time constant selection			Related mode	S
	Setting range	1~7	Unit	-	Factory setting	1
P10.53	Name	Segment 12 speed command			Related mode	S
	Setting range	-6000~6000	Unit	rpm	Factory setting	1200
P10.54	Name	Segment 12 speed command running time			Related mode	S
	Setting range	0~65535	Unit	ms	Factory setting	120

P10.55	Name	Segment 12 acceleration and deceleration time constant selection			Related mode	S
	Setting range	1~7	Unit	-	Factory setting	1
P10.56	Name	Segment 13 speed command			Related mode	S
	Setting range	-6000~6000	Unit	rpm	Factory setting	1300
P10.57	Name	Segment 13 speed command running time			Related mode	S
	Setting range	0~65535	Unit	ms	Factory setting	130
P10.58	Name	Segment 13 acceleration and deceleration time constant selection			Related mode	S
	Setting range	1~7	Unit	-	Factory setting	1
P10.59	Name	Segment 14 speed command			Related mode	S
	Setting range	-6000~6000	Unit	rpm	Factory setting	1400
P10.60	Name	Segment 14 speed command running time			Related mode	S
	Setting range	0~65535	Unit	ms	Factory setting	140
P10.61	Name	Segment 14 acceleration and deceleration time constant selection			Related mode	S
	Setting range	1~7	Unit	-	Factory setting	1
P10.62	Name	Segment 15 speed command			Related mode	S
	Setting range	-6000~6000	Unit	rpm	Factory setting	1500
P10.63	Name	Segment 15 speed command running time			Related mode	S
	Setting range	0~65535	Unit	ms	Factory setting	150
P10.64	Name	Segment 15 acceleration and deceleration time constant selection			Related mode	S
	Setting range	1~7	Unit	-	Factory setting	1
P10.65	Name	Segment 16 speed command			Related mode	S
	Setting range	-6000~6000	Unit	rpm	Factory setting	1600
P10.66	Name	Segment 16 speed command running time			Related mode	S
	Setting range	0~65535	Unit	ms	Factory setting	160
P10.67	Name	Segment 16 acceleration and deceleration time constant selection			Related mode	S
	Setting range	1~7	Unit	-	Factory setting	1

7.11. Group P11: Auxiliary Display

The following parameters are used to display the CiA402-related objects in CANopen and EtherCAT bus mode, which is convenient for viewing object values and troubleshooting.

P11.00	Name	0x603F(Error code)			Related mode	-
	Setting range	-	Unit	-	Factory setting	-
P11.01	Name	0x6040(Control word)			Related mode	-
	Setting range	-	Unit	-	Factory setting	-
P11.02	Name	0x6041(Status word)			Related mode	-
	Setting range	-	Unit	-	Factory setting	-
P11.03	Name	0x605A(Quick stop mode selection)			Related mode	-
	Setting range	-	Unit	-	Factory setting	-
P11.04	Name	0x605B (Shutdown mode selection)			Related mode	-
	Setting range	-	Unit	-	Factory setting	-
P11.05	Name	0x605C (Prohibition of operation mode selection)			Related mode	-
	Setting range	-	Unit	-	Factory setting	-
P11.06	Name	0x605E(Fault shutdown mode selection)			Related mode	-
	Setting range	-	Unit	-	Factory setting	-
P11.07	Name	0x6060 (Mode selection)			Related mode	-
	Setting range	-	Unit	-	Factory setting	-
P11.08	Name	0x6061(Operating mode display)			Related mode	-
	Setting range	-	Unit	-	Factory setting	-
P11.09 P11.10	Name	0x6062 (Position command)			Related mode	-
	Setting range	-	Unit	Command unit	Factory setting	-
P11.11 P11.12	Name	0x6063(Position feedback)			Related mode	-
	Setting range	-	Unit	Encoder unit	Factory setting	-
P11.13 P11.14	Name	0x6064(Position feedback)			Related mode	-
	Setting range	-	Unit	Command unit	Factory setting	-

P11.15 P11.16	Name	0x6065 (Excessive position deviation threshold)			Related mode	-
	Setting range	-	Unit	Command unit	Factory setting	-
P11.17	Name	0x6066(Position deviation time window)			Related mode	-
	Setting range	-	Unit	ms	Factory setting	-
P11.18 P11.19	Name	0x6067 (Position reaches threshold)			Related mode	-
	Setting range	-	Unit	-	Factory setting	-
P11.20	Name	0x6068 (Position reaches time window)			Related mode	-
	Setting range	-	Unit	ms	Factory setting	-
P11.21 P11.22	Name	0x606C(Speed feedback)			Related mode	-
	Setting range	-	Unit	Command unit/s	Factory setting	-
P11.23	Name	0x606D(Speed reaches threshold)			Related mode	-
	Setting range	-	Unit	rpm	Factory setting	-
P11.24	Name	0x606E (Speed reaches time window)			Related mode	-
	Setting range	-	Unit	ms	Factory setting	-
P11.25	Name	0x6071(Target torque)			Related mode	-
	Setting range	-	Unit	0.1%	Factory setting	-
P11.26	Name	0x6072 (Maximum torque)			Related mode	-
	Setting range	-	Unit	0.1%	Factory setting	-
P11.27	Name	0x6073 (Maximum current)			Related mode	-
	Setting range	-	Unit	0.1%	Factory setting	-
P11.28	Name	0x6074 (Internal target torque)			Related mode	-
	Setting range	-	Unit	0.1%	Factory setting	-
P11.29	Name	0x6077 (Torque feedback)			Related mode	-
	Setting range	-	Unit	0.1%	Factory setting	-
P11.30 P11.31	Name	0x607A(Target position)			Related mode	-
	Setting range	-	Unit	Command unit	Factory setting	-
P11.32 P11.33	Name	0x607C (Origin offset)			Related mode	-
	Setting range	-	Unit	Command unit	Factory setting	-

P11.34 P11.35	Name	0x607D_1 (Minimum software absolute position limit)			Related mode	-
	Setting range	-	Unit	Command unit	Factory setting	-
P11.36 P11.37	Name	0x607D_2 (Maximum software absolute position limit)			Related mode	-
	Setting range	-	Unit	Command unit	Factory setting	-
P11.38	Name	0x607E(Command polarity)			Related mode	-
	Setting range	-	Unit	-	Factory setting	-
P11.39 P11.40	Name	0x607F(Maximum contour speed)			Related mode	-
	Setting range	-	Unit	Command unit/s	Factory setting	-
P11.41 P11.42	Name	0x6081 (Contour speed)			Related mode	-
	Setting range	-	Unit	Command unit/s	Factory setting	-
P11.43 P11.44	Name	0x6083(Contour acceleration)			Related mode	-
	Setting range	-	Unit	Command unit/s ²	Factory setting	-
P11.45 P11.46	Name	0x6084(Contour deceleration)			Related mode	-
	Setting range	-	Unit	Command unit/s ²	Factory setting	-
P11.47 P11.48	Name	0x6085(Quick stop deceleration)			Related mode	-
	Setting range	-	Unit	Command unit/s ²	Factory setting	-
P11.49 P11.50	Name	0x6087(Torque slope)			Related mode	-
	Setting range	-	Unit	0.1%/s	Factory setting	-
P11.51 P11.52	Name	0x6091_1 (Gear ratio molecular/Motor resolution)			Related mode	-
	Setting range	-	Unit	-	Factory setting	-
P11.53 P11.54	Name	0x6091_2(Gear ratio denominator/shaft resolution)			Related mode	-
	Setting range	-	Unit	-	Factory setting	-
P11.55	Name	0x6098(Homing method)			Related mode	-
	Setting range	-	Unit	-	Factory setting	-
P11.56 P11.57	Name	0x6099_1(Search deceleration point signal speed)			Related mode	-
	Setting range	-	Unit	Command unit/s	Factory setting	-
P11.58 P11.59	Name	0x6099_2(Search homing signal speed)			Related mode	-
	Setting range	-	Unit	Command unit/s	Factory setting	-

P11.60 P11.61	Name	0x609A(Homing acceleration)			Related mode	-
	Setting range	-	Unit	Command unit/s ²	Factory setting	-
P11.62 P11.63	Name	0x60B0(Position offset)			Related mode	-
	Setting range	-	Unit	Command unit	Factory setting	-
P11.64 P11.65	Name	0x60B1 (Speed offset)			Related mode	-
	Setting range	-	Unit	Command unit/s	Factory setting	-
P11.66	Name	0x60B2(Torque offset)			Related mode	-
	Setting range	-	Unit	0.1%	Factory setting	-
P11.67	Name	0x60B8 (Probe function)			Related mode	-
	Setting range	-	Unit	-	Factory setting	-
P11.68	Name	0x60B9(Probe status)			Related mode	-
	Setting range	-	Unit	-	Factory setting	-
P11.69 P11.70	Name	0x60BA(Probe 1 rising edge position feedback)			Related mode	-
	Setting range	-	Unit	Command unit	Factory setting	-
P11.71 P11.72	Name	0x60BB (Probe 1 falling edge position feedback)			Related mode	-
	Setting range	-	Unit	Command unit	Factory setting	-
P11.73 P11.74	Name	0x60BC(Probe 2 rising edge position feedback)			Related mode	-
	Setting range	-	Unit	Command unit	Factory setting	-
P11.75 P11.76	Name	0x60BD(Probe 2 falling edge position feedback)			Related mode	-
	Setting range	-	Unit	Command unit	Factory setting	-
P11.77	Name	0x60D5(Probe 1 rising edge counter)			Related mode	-
	Setting range	-	Unit	-	Factory setting	-
P11.78	Name	0x60D6 (Probe 1 falling edge counter)			Related mode	-
	Setting range	-	Unit	-	Factory setting	-
P11.79	Name	0x60D7 (Probe 2 rising edge counter)			Related mode	-
	Setting range	-	Unit	-	Factory setting	-
P11.80	Name	0x60D8 (Probe 2 falling edge counter)			Related mode	-
	Setting range	-	Unit	-	Factory setting	-

P11.81	Name	0x60E0(Maximum forward torque limit)			Related mode	-
	Setting range	-	Unit	0.1%	Factory setting	-

P11.82	Name	0x60E1 (Maximum negative torque limit)			Related mode	-
	Setting range	-	Unit	0.1%	Factory setting	-

P11.83 P11.84	Name	0x60F4 (Position offset)			Related mode	-
	Setting range	-	Unit	Command unit	Factory setting	-

P11.85 P11.86	Name	0x60FC(Position command)			Related mode	-
	Setting range	-	Unit	Command unit	Factory setting	-

P11.87 P11.88	Name	0x60FD (Digital input)			Related mode	-
	Setting range	-	Unit	-	Factory setting	-

P11.89 P11.90	Name	0x60FE_1(Physical output)			Related mode	-
	Setting range	-	Unit	-	Factory setting	-

P11.91 P11.92	Name	0x60FE_2(Physical output enable)			Related mode	-
	Setting range	-	Unit	-	Factory setting	-

P11.93 P11.94	Name	0x60FF (Target speed)			Related mode	-
	Setting range	-	Unit	Command unit/s	Factory setting	-

P11.95 P11.96	Name	0x6502 (Supported servo operation mode)			Related mode	-
	Setting range	-	Unit	-	Factory setting	-

7.12. Group P12: Auxiliary Functions

P12.00	Name	Save parameters to the EEPROM of the drive			Related mode	-
	Setting range	0~1	Unit	-	Factory setting	0

P12.01	Name	Read parameters from the EEPROM of the drive			Related mode	-
	Setting range	0~1	Unit	-	Factory setting	0

P12.02	Name	Restore factory default parameter values			Related mode	-
	Setting range	0~1	Unit	-	Factory setting	0

P12.03	Name	Reset driver failure			Related mode	-
	Setting range	0~1	Unit	-	Factory setting	0

P12.04	Name	Reserved			Related mode	-
	Setting range	-	Unit	-	Factory setting	-

P12.05	Name	Reset the encoder multi-turn value			Related mode	-
	Setting range	0~1	Unit	-	Factory setting	0

P12.06	Name	Reset the encoder multi-turn value and fault			Related mode	-
	Setting range	0~1	Unit	-	Factory setting	0

P12.07	Name	Reset drive			Related mode	-
	Setting range	-	Unit	-	Factory setting	-

P12.08	Name	Reset fault record			Related mode	-
	Setting range	0~1	Unit	-	Factory setting	0

P12.09	Name	Communication control operation position command type			Related mode	PS
	Setting range	0~1	Unit	-	Factory setting	0

In the position control mode (P01.00=0), when the position command source is set to communication control (P03.00=3), set the type of position command.
 0: Incremental position mode
 1: Absolute position mode

P12.10	Name	Communication control operation start/stop command			Related mode	PS
	Setting range	0~6	Unit	0.1ms	Factory setting	6

In the position control mode (P01.00=0), when the position command source is set to communication control (P03.00=3), it is used for communication to write the motor start/stop command.

P12.10 write value	Description
0	Write: Trigger the motor to stop. After the motor responds to the start-stop command, set P12.10 to 6.
1	Write: Trigger the motor to run forward and stop after the run command set by P04.60. After the motor responds to the start-stop command, set P12.10 to 6.
2	Write: Trigger the motor to run reversely and stop after the running command set by P04.60. After the motor responds to the start-stop command, set P12.10 to 6.
3	Write: Trigger the motor to jog forward. After the motor responds to the start-stop command, set P12.10 to 6.
4	Write: Trigger the motor to jog reverse. After the motor responds to the start-stop command, set P12.10 to 6.
5	Write: Trigger the emergency stop of the motor. After the motor responds to the start-stop command, set P12.10 to 6.
6	Write: Meaningless. Read: Indicating that the motor is running or waiting to be triggered to run.

P12.11	Name	Reserved			Related mode	-
	Setting range	-	Unit	-	Factory setting	-

P12.12	Name	Communication control demonstration operation delay time			Related mode	PS
	Setting range	0~65535	Unit	ms	Factory setting	100

P12.13	Name	Communication control demonstration operation start/stop command			Related mode	PS
	Setting range	0~2	Unit	-	Factory setting	0

In the position control mode (P01.00=0), when the position command source is set to communication control (P03.00=3), it is used to write the start/stop command of the motor demonstration operation by communication. In the demo running mode, the motor will start in reciprocating or single direction (P04.65=0/1) according to the running command, speed, acceleration and subtraction time constant set by P04.60~P04.64, and start in positive or negative direction (P04.66=0/1), run the number of times set by P04.67. After completing the set running command each time, after delaying the delay time set by P12.12, restart again and run in this cycle.

P12.13 write value	Description
0	Write: Trigger the motor to stop the operation of the internal test demonstration.
1	Write: Trigger the motor to start the demonstration operation. After the drive responds to the command, P12.13 is set to 2.
2	Writing: Meaningless; reading: Indicating that the motor is working in the demo mode

P12.14	Name	Clear position error			Related mode	P
	Setting range	0~1	Unit	-	Factory setting	0

P12.15	Name	Reserved			Related mode	-
	Setting range	-	Unit	-	Factory setting	-

P12.16	Name	Data sampling channel 1			Related mode	-
	Setting range	0~65535	Unit	-	Factory setting	0

P12.17	Name	Data sampling channel 2			Related mode	-
	Setting range	0~655	Unit	-	Factory setting	0

P12.18	Name	Data sampling interval			Related mode	-
	Setting range	0~65535	Unit	0.1ms	Factory setting	0

P12.19	Name	Data sampling start flag			Related mode	-
	Setting range	0~1	Unit	-	Factory setting	0

P12.20	Name	Save motor related parameters to encoder EEPROM			Related mode	-
	Setting range	0~2	Unit	-	Factory setting	0
Non-manufacturer after-sales personnel or special designation by the manufacturer, please do not operate this parameter, otherwise it may cause abnormal operation of the motor.						

P12.21	Name	Test energy consumption braking action and feedback			Related mode	-
	Setting range	0~2	Unit	-	Factory setting	0
0: No effect/wait to start test/test end 1: Start dynamic braking/feedback action test 2: Abnormality in the energy consumption braking feedback test						

7.13. Group P13: Monitoring Parameters

P13.00	Name	Operation status			Related mode	-
	Setting range	-	Unit	-	Factory setting	Display
Display the operation status of the servo drive. 0: The servo driver is not enabled; 1: Servo drive is enabled.						

P13.01	Name	Motor speed			Related mode	-
	Setting range	-	Unit	rpm	Factory setting	Display
Display the actual speed of the servo motor, after rounding the display, the accuracy is 1rpm.						

P13.02	Name	Speed command			Related mode	-
	Setting range	-	Unit	rpm	Factory setting	Display
Display the current speed command value of the servo drive, after rounding the display, the accuracy is 1rpm.						

P13.03	Name	Motor torque			Related mode	-
	Setting range	-	Unit	%	Factory setting	Display
Display actual servo motor torque, 100% corresponding to 1 times motor rated torque.						

P13.04	Name	Torque command			Related mode	-
	Setting range	-	Unit	%	Factory setting	Display
Display the current torque command value of the servo drive, 100% corresponding to 1 times the motor rated torque.						

P13.05	Name	Operating current			Related mode	-
	Setting range	-	Unit	%	Factory setting	Display
Display the actual operating current of the servo motor, 100% corresponds to the rated current of the servo motor.						

P13.07 P13.08	Name	Position command counter			Related mode	-
	Setting range	-	Unit	Command unit	Factory setting	Display
In position control mode, during servo operation, the number of position commands that have not been divided and multiplied by the electronic gear ratio are counted and displayed. P13.07 and P13.08 are combined into a 32-bit value, where P13.07 is the low 16-bit value, and P13.08 is the high 16-bit value. Subsequent use P13.07 to represent the 32-bit parameter.						

P13.09 P13.10	Name	Position command counter *			Related mode	-
	Setting range	-	Unit	Encoder unit	Factory setting	Display
In position control mode, during servo operation, the number of position commands that have not been divided and multiplied by the electronic gear ratio are counted and displayed. P13.09 and P13.10 are combined into a 32-bit value, where P13.09 is the low 16-bit value, and P13.10 is the high 16-bit value. Subsequent use P13.09 to represent the 32-bit parameter.						

P13.11 P13.12	Name	Position feedback counter			Related mode	-
	Setting range	-	Unit	Encoder unit	Factory setting	Display
Used to count the number of encoder feedback pulses since the last clearing. P13.11 and P13.12 are combined into a 32-bit value, where P13.11 is the lower 16-bit value and P13.12 is the upper 16-bit value. Subsequent use P13.11 to represent the 32-bit parameter.						

P13.13 P13.14	Name	Position deviation counter			Related mode	-
	Setting range	-	Unit	Command unit	Factory setting	Display
In position control mode, statistics and display the position command deviation value. P13.13 and P13.14 are combined into a 32-bit value, where P13.13 is the low 16-bit value, and P13.14 is the high 16-bit value. Subsequent use P13.13 to represent the 32-bit parameter.						

P13.15 P13.16	Name	Position deviation counter *			Related mode	-
	Setting range	-	Unit	Encoder unit	Factory setting	Display
In the position control mode, statistics and display the position deviation value after the electronic gear ratio is divided and multiplied. P13.15 and P13.16 are combined into a 32-bit value, where P13.15 is the low 16-bit value, and P13.16 is the high 16-bit value. Subsequent use P13.15 to represent the 32-bit parameter.						

P13.17	Name	Position command speed			Related mode	-
	Setting range	-	Unit	rpm	Factory setting	Display
Display the speed value corresponding to the position command of a single position control cycle of the drive.						

P13.18	Name	Position command frequency			Related mode	-
	Setting range	-	Unit	KHz	Factory setting	Display
Display the pulse frequency corresponding to the position command of a single position control cycle of the drive.						

P13.19	Name	Input signal monitoring			Related mode	-																						
	Setting range	-	Unit	-	Factory setting	Display																						
<p>Display the current level status of the IN hardware terminal of the drive. BIT corresponding to "1" means the drive INx terminal optocoupler is turned on, BIT corresponding to "0" means that the drive INx terminal optocoupler is not turned on.</p> <table border="1"> <thead> <tr> <th>BIT</th> <th>Description</th> </tr> </thead> <tbody> <tr><td>0</td><td>IN1 input status</td></tr> <tr><td>1</td><td>IN2 input status</td></tr> <tr><td>2</td><td>IN3 input status</td></tr> <tr><td>3</td><td>IN4 input status</td></tr> <tr><td>4</td><td>IN5 input status</td></tr> <tr><td>5</td><td>IN6 input status</td></tr> <tr><td>6</td><td>IN7 input status</td></tr> <tr><td>7</td><td>IN8 input status</td></tr> <tr><td>8</td><td>IN9 input status</td></tr> <tr><td>9~15</td><td>Reserved</td></tr> </tbody> </table>							BIT	Description	0	IN1 input status	1	IN2 input status	2	IN3 input status	3	IN4 input status	4	IN5 input status	5	IN6 input status	6	IN7 input status	7	IN8 input status	8	IN9 input status	9~15	Reserved
BIT	Description																											
0	IN1 input status																											
1	IN2 input status																											
2	IN3 input status																											
3	IN4 input status																											
4	IN5 input status																											
5	IN6 input status																											
6	IN7 input status																											
7	IN8 input status																											
8	IN9 input status																											
9~15	Reserved																											

P13.20	Name	Output signal monitoring			Related mode	-																
	Setting range	-	Unit	-	Factory setting	Display																
<p>Display the current status of the OUT hardware terminal of the drive. BIT corresponding to "1" means that the OUTx terminal of the drive has a signal output (only means that the current OUTx terminal of the drive has a driving signal, and does not mean that the current driver's output port is normally output), and a BIT corresponding to "0" means that there is no output signal from the OUTx terminal of the drive.</p> <table border="1"> <thead> <tr> <th>BIT</th> <th>Description</th> </tr> </thead> <tbody> <tr><td>0</td><td>OUT1 output status</td></tr> <tr><td>1</td><td>OUT2 output status</td></tr> <tr><td>2</td><td>OUT3 output status</td></tr> <tr><td>3</td><td>OUT4 output status</td></tr> <tr><td>4</td><td>OUT5 output status</td></tr> <tr><td>5</td><td>OUT6 output status</td></tr> <tr><td>6~15</td><td>Reserved</td></tr> </tbody> </table>							BIT	Description	0	OUT1 output status	1	OUT2 output status	2	OUT3 output status	3	OUT4 output status	4	OUT5 output status	5	OUT6 output status	6~15	Reserved
BIT	Description																					
0	OUT1 output status																					
1	OUT2 output status																					
2	OUT3 output status																					
3	OUT4 output status																					
4	OUT5 output status																					
5	OUT6 output status																					
6~15	Reserved																					

P13.21 P13.22	Name	Motor current mechanical angle			Related mode	-
	Setting range	-	Unit	Encoder unit	Factory setting	Display
<p>Display the current mechanical angle of the motor (encoder unit), 0 corresponds to the mechanical angle 0. P13.21 and P13.22 are combined into a 32-bit value, where P13.21 is the low 16-bit value, and P13.22 is the high 16-bit value. Subsequent use P13.21 to represent the 32-bit parameter. Actual mechanical angle = (P13.21 ÷ encoder pulse number) × 360°</p>						

P13.23	Name	Motor current electrical angle			Related mode	-
	Setting range	-	Unit	Degree	Factory setting	Display
<p>Display the current electrical angle of the motor, P13.23 = (P13.21 ÷ encoder pulse number) × 360°</p>						

P13.24	Name	Drive current voltage			Related mode	-
	Setting range	-	Unit	0.1V	Factory setting	Display

P13.25 P13.26	Name	Encoder status register			Related mode	-
	Setting range	-	Unit	-	Factory setting	Display

Display the status information of the encoder. P13.25 and P13.26 are combined into a 32-bit value, where P13.25 is the low 16-bit value, and P13.26 is the high 16-bit value. Subsequent use P13.25 to represent the 32-bit parameter. The 32-bit data corresponds to 1 to indicate that the event has occurred, and 0 to indicate that there is no such event. The detailed description is as follows:

BIT	Description
0	Absolute encoder fault
1	Absolute encoder command check bit fault
2	Absolute encoder delimiter fault
3	Absolute encoder overspeed fault
4	Absolute encoder status fault
5	Absolute encoder count fault
6	Absolute encoder count overflow fault
7	Absolute encoder overheating fault
8	Absolute encoder multi-turn data fault
9	Absolute encoder battery fault 1
10	Absolute encoder battery fault 2
11	Absolute encoder data receiving timeout fault 1
12	Absolute encoder data receiving timeout fault 2
13	Absolute encoder receiving command fault
14	Absolute encoder verification fault
15	Absolute encoder check command error, if this error occurs, please contact the manufacturer
16	Absolute encoder receiving status flag fault
17	Absolute encoder receiving fault
18	Incremental encoder hall signal fault
19	Incremental encoder disconnection fault
20	Incremental encoder Z phase signal latch flag
21	Incremental encoder Z phase signal last cycle latch flag
22	Encoder type/resolution setting error flag
23	Encoder calibration fault flag
24	Bus type incremental encoder index signal flag
25	Index position latch flag of bus type incremental encoder
26	UVW signal error flag of bus type incremental encoder
27:28	Bus type incremental encoder index status
29~31	Reserved

P13.27 P13.28	Name	External pulse counter			Related mode	-
	Setting range	-	Unit	Command unit	Factory setting	Display

Displays the number of external input pulses received by the drive since the last reset. P13.27 and p13.28 are combined into a 32-bit value, where p13.27 is the low 16 bit value and p13.28 is the high 16 bit value. Subsequently, p13.27 is used to represent the 32-bit parameter.

P13.29	Name	Frequency division output pulse counting			Related mode	-
	Setting range	-	Unit	Command pulse	Factory setting	Display

DRV series servo drivers are not available

P13.30 P13.31	Name	Motor current position			Related mode	-
	Setting range	-	Unit	Command unit	Factory setting	Display

Display the actual position of the motor shaft, the unit is command pulse. P13.30 and P13.31 are combined into a 32-bit signed value, where P13.30 is the low 16-bit value, and P13.31 is the high 16-bit value. Subsequent use P13.30 to represent the 32-bit parameter.

P13.32 P13.33	Name	Target position(0x607A)			Related mode	-
	Setting range	-	Unit	Command unit	Factory setting	Display

In CANopen and EtherCAT models, it is used to display the current target position 0x607A. P13.32 and P13.33 are combined into a 32-bit signed value, where P13.32 is the low 16-bit value, and P13.33 is the high 16-bit value. Subsequent use P13.32 to represent the 32-bit parameter.

P13.36	Name	Fault code			Related mode	-
	Setting range	-	Unit	-	Factory setting	Display

For the specific content of the fault code, please refer to the "Troubleshooting" chapter.

P13.40 P13.41	Name	Motor encoder single-turn value			Related mode	-
	Setting range	-	Unit	Encoder unit	Factory setting	Display

Display the current single-turn value of the motor encoder, ranging from 0 to encoder resolution. P13.40 and P13.41 are combined into a 32-bit unsigned value, where P13.40 is the low 16-bit value and P13.41 is the high 16-bit value. Subsequent use P13.40 to represent the 32-bit parameter.

P13.42 P13.43	Name	Motor encoder multi-turn value			Related mode	-
	Setting range	-	Unit	Turn	Factory setting	Display

Display the current multi-turn value of the motor encoder. P13.42 and P13.43 are combined into a 32-bit signed value, where P13.42 is the low 16-bit value and P13.43 is the high 16-bit value. Subsequent use P13.42 to represent the 32-bit parameter.

P13.44 P13.45	Name	Internal position given counter			Related mode	-
	Setting range	-	Unit	Encoder unit	Factory setting	Display

Display the current multi-turn value of the motor encoder. P13.44 and P13.45 are combined into a 32-bit signed value, where P13.44 is the low 16-bit value, and P13.45 is the high 16-bit value. Subsequent use P13.44 to represent the 32-bit parameter.

P13.46 P13.47	Name	Internal position feedback counter			Related mode	-
	Setting range	-	Unit	Encoder unit	Factory setting	Display

Display the current multi-turn value of the motor encoder. P13.46 and P13.47 are combined into a 32-bit signed value, where P13.46 is the low 16-bit value and P13.47 is the high 16-bit value. Subsequent use P13.46 to represent the 32-bit parameter.

8. Communication

The servo drive has Modbus RTU (RS-232, RS-485) communication function, with the upper computer communication software, it can realize multiple functions such as parameter modification, parameter query and servo drive status monitoring.

8.1. Communication Parameters Setting

The RS-485 communication protocol has a single-master multi-slave communication mode, which can support network operation of multiple servo drives. RS-232 communication protocol does not support networking of multiple servo drivers.

◆ Servo drive default communication settings:

Communication mode	Axis address	Baud rate	Data Format
RS485 communication	1	115200 bps	1 start bit + 8 data bits + 1 stop bit
RS232 communication	1 (Fixed and unchangeable)	115200 bps	1 start bit + 8 data bits + 1 stop bit

1. RS485 communication settings

(1) Set the servo driver axis address P08.00

When multiple servo drives are networked, each drive can only have a unique address, otherwise it will cause communication abnormalities and fail to communicate. Among them:

- ◆ 0: broadcast address
- ◆ 1~127: slave address

The host computer can write to all slave drives through the broadcast address. The slave drive receives the broadcast address data frame and performs corresponding operations, but does not respond to data.

(2) Set the communication rate between the servo drive and the host computer P08.01

The speed of the servo drive and the communication speed of the host computer must be set to be consistent, otherwise the communication will not be possible. When multiple servo drives are networked, if the communication baud rate of a servo drive is inconsistent with the host, it will cause the servo axis communication error and may affect the normal communication of other servo drives.

(3) Set the data frame format P08.02 for the communication between the drive and the master

Servo drive provides 6 communication data formats:

P08.02 setting value	Communication data frame format
0	1 start bit + 8 data bits + 1 stop bit
1	1 start bit + 8 data bits + 2 stop bits
2	1 start bit + 8 data bits + 1 even parity bit + 1 stop bit
3	1 start bit + 8 data bits + 1 even parity bit + 2 stop bits
4	1 stop bit + 8 data bits + 1 odd parity bit + 1 stop bit
5	1 stop bit + 8 data bits + 1 odd parity bit + 2 stop bits

Remark:

The data frame format of the host computer must conform to the above format, otherwise it cannot communicate with the drive.

2. RS232 communication settings

★ Associated parameter description

Parameter	Name	Range	Function	Effective time	Default
P08.30	RS232 communication axis address	-	Set the station number of RS232 communication	After saving and restarting	1
P08.31	RS232 communication baud rate	0~5	Set the baud rate of RS232 communication	After saving and restarting	5
P08.32	RS232 communication data format	0~5	Set the data format of RS232 communication	After saving and restarting	0

8.2. MODBUS Communication Protocol

The Modbus protocol, designed by MODDICON company, is a bus protocol that allows a master and one or more slaves to share data, which consists of 16-bit registers. The master can read and write a single register or multiple registers. The standard Modbus port on a Modicon controller is using an RS-232 compatible serial interface that defines the connector, wiring cable, signal class, transmission baud rate and parity. Controller communication uses master-slave technology, where the master initiates the data transfer, called a query. And other devices (slaves) return data in response to the query, or process the action requested by the query. Master devices include processors, programmers, and PLCs, and slaves include programmable controllers, servo drives, and stepper drives. The master-slave query-feedback mechanism is shown below:

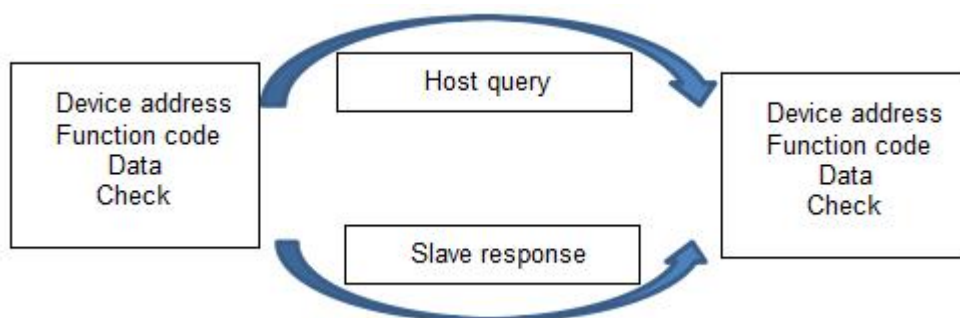

◆ Note: The communication data frame structure of this servo drive adopts RTU mode.

The MODBUS communication function code used by the servo drive is described as follows:

Function code	Definition
0x03	Read register data
0x06	Write single register data
0x10	Write multiple register data

- ◆ Note: The relationship between the parameter number in the manual and the register address in Modbus communication: if the parameter number is P08.02, the Modbus communication register address is 802 (Decimal)

8.2.1. Read Register Data: 0x03

1. Request frame format

START	Idle time greater than or equal to 3.5 characters, indicating the start of a frame
ADDR	Servo axis address
CMD	Function code: 0x03
REGISTER_ADDRH	Register start address high byte
REGISTER_ADDRL	Register start address low byte
DATA_NUMBERH	The number of registers to be read N (H), high byte
DATA_NUMBERL	The number of registers to be read N (L), low byte
CRCL	CRC check code, low byte
CRCH	CRC check code, high byte
END	Idle time greater than or equal to 3.5 characters, one frame ends

- ◆ Note: The register start address range is 0x0000 to 0xFFFF, and the register number range is 0x1 to 0x7D

2. Response frame format

START	Idle time greater than or equal to 3.5 characters, indicating the start of a frame
ADDR	Servo axis address
CMD	Function code: 0x03
DATA_LENGTH	Number of data bytes returned, equal to the number of registers N*2
DATA[0]	Starting data value, high byte
DATA[1]	Starting data value, low byte
DATA[...]
DATA[N*2-1]	Last data value, low byte
CRCL	CRC check code, low byte
CRCH	CRC check code, high byte
END	Idle time greater than or equal to 3.5 characters, one frame ends

3. Example

(1) Host sends request frame

0x01	0x03	0x00	0x64	0x00	0x02	CRCL	CRCH
------	------	------	------	------	------	------	------

This request frame means: read 2 (0x0002) word length data from the servo drive whose axis address is 0x01 and the start register address is 100 (0x0064).

(2) Slave response frame

0x01	0x03	0x04	0x01	0x20	0x00	0x59	CRCL
------	------	------	------	------	------	------	------

The response frame means: the slave returns 4 bytes (2 words long) of data, and the data content is 0x0120, 0x0059.

8.2.2. Write a Single Register: 0x06

1. Request frame format

START	Idle time greater than or equal to 3.5 characters, indicating the start of a frame
ADDR	Servo axis address
CMD	Function code: 0x06
REGISTER_ADDRH	High byte of written register address
REGISTER_ADDRL	Low byte of written register address
DATA[0]	Write data, high byte
DATA[1]	Write data, low byte
CRCL	CRC check code, low byte
CRCH	CRC check code, high byte
END	Idle time greater than or equal to 3.5 characters, one frame ends

2. Response frame format

START	Idle time greater than or equal to 3.5 characters, indicating the start of a frame
ADDR	Servo axis address
CMD	Function code: 0x06
REGISTER_ADDRH	High byte of written register address
REGISTER_ADDRL	Low byte of written register address
DATA[0]	Write data, high byte
DATA[1]	Write data, low byte
CRCL	CRC check code, low byte
CRCH	CRC check code, high byte
END	Idle time greater than or equal to 3.5 characters, one frame ends

3. Example

(1) Host sends request frame

0x01	0x06	0x00	0x64	0x00	0x02	CRCL	CRCH
------	------	------	------	------	------	------	------

This request frame means: write data value 0x0002 to the servo drive with axis address 0x01 and register address 100 (0x0064).

(2) Slave response frame

0x01	0x06	0x00	0x64	0x00	0x02	CRCL	CRCH
------	------	------	------	------	------	------	------

This response frame indicates that the host has successfully written data into the servo drive register.

8.2.3. Write Multiple Registers: 0x10

1. Request frame format

START	Idle time greater than or equal to 3.5 characters, indicating the start of a frame
ADDR	Servo axis address
CMD	Function code: 0x10
REGISTER_ADDRH	High byte of the start address of the written register
REGISTER_ADDRL	Low byte of the start address of the written register
DATA_NUMBERH	The number of registers to be written N (H), high byte
DATA_NUMBERL	The number of registers to be written N (L), low byte
DATA_LENGTH	Need to write the number of bytes corresponding to the number of registers N*2
DATA[0]	Write high byte of start register data
DATA[1]	Write low byte of start register data
DATA[...]
DATA[N*2-1]	Write low byte of last register data
CRCL	CRC check code, low byte
CRCH	CRC check code, high byte
END	Idle time greater than or equal to 3.5 characters, one frame ends

2. Response frame format

START	Idle time greater than or equal to 3.5 characters, indicating the start of a frame
ADDR	Servo axis address
CMD	Function code: 0x10
REGISTER_ADDRH	High byte of the start address of the written register
REGISTER_ADDRL	Low byte of the start address of the written register
DATA_NUMBERH	The number of registers to be written N (H), high byte
DATA_NUMBERL	The number of registers to be written N (L), low byte
CRCL	CRC check code, low byte
CRCH	CRC check code, high byte
END	Idle time greater than or equal to 3.5 characters, one frame ends

◆ Note: The maximum number of registers that can be written at one time is 120.

3. Example

(1) Host sends request frame

0x01	0x10	0x00	0x64	0x00	0x02	0x04	0x12	0x00	0x00	0x52	CRCL	CRCH
------	------	------	------	------	------	------	------	------	------	------	------	------

The request frame indicates that 2 (0x0002) words long data (4 bytes) are written to the servo drive with the axis address of 0x01, the starting register address of 100 (0x0064), and the written data are 0x1200 and 0x0052.

(2) Slave response frame

0x01	0x10	0x00	0x64	0x00	0x02	CRCL	CRCH
------	------	------	------	------	------	------	------

This response frame means: the host successfully writes the data into the servo drive register.

8.2.4. Error Response Frame Format

1. Error response frame format

START	Idle time greater than or equal to 3.5 characters, indicating the start of a frame
ADDR	Servo axis address
CMD	0x80 + Function code
ERROR_CODE	Error code
CRCL	CRC check code, low byte
CRCH	CRC check code, high byte
END	Idle time greater than or equal to 3.5 characters, one frame ends

2. Error code

Error code	Coding description
0x01	Illegal function code
0x02	Illegal data address
0x03	Illegal data
0x04	Slave equipment failure

3. Example

(1) Host sends request frame

0x01	0x03	0x00	0x64	0x00	0x02	CRCL	CRCH
------	------	------	------	------	------	------	------

This request frame means: read 2 (0x0002) word length data from the servo drive whose axis address is 0x01 and the start register address is 100 (0x0064).

(2) Slave response frame

0x01	0x03	0x04	0x01	0x20	0x00	0x59	CRCL
------	------	------	------	------	------	------	------

The response frame means: the slave returns 4 bytes (2 words long) of data, and the data content is 0x0120, 0x0059.

If the slave response is:

0x01	0x83	0x02	CRCL	CRCH
------	------	------	------	------

The response frame means that 0x83 indicates an error occurred in communication, and the error coding is 0x02.

8.2.5.CRC Check

The upper computer and the servo must use the same CRC check algorithm for communication, otherwise CRC check error will occur, resulting in communication failure, and the servo drive will not report CRC check error. The servo drive adopts 16-bit CRC, with low byte first and high byte last. The CRC function is as follows:

```

unsigned short CalcCRCbyAlgorithm(unsigned char* pDataBuffer, unsigned long usDataLen)
{
const unsigned short POLYNOMIAL = 0xA001;
unsigned short wCrc;
int iByte, iBit;
wCrc = 0xFFFF;
For(iByte = 0; iByte < usDataLen; iByte++)
{
    wCrc ^= *(pDataBuffer + iByte);
    For(iBit = 0; iBit <= 7; iBit++)
    {
        If(wCrc & 0x0001)
        {
            wCrc >>= 1;
            wCrc ^= POLYNOMIAL;
        }
        else
        {
            wCrc >>= 1;
        }
    }
}
return wCrc;
}

```

9. Troubleshooting

9.1. Error Code

Error code	Fault content
AL.000	Normal state
AL.100	<p>Parameter reading error</p> <p>A. Typically occurs after a firmware upgrade or when parameter reading operations are performed, the version of the stored parameters in the drive EEPROM does not match or the validation error. Need to re-import the firmware and save it.</p> <p>B. An alarm occurs when the drive does not upgrade the firmware. It is caused by an error in reading the internal parameters of the drive. Please power off the drive completely for 30s, and then restart the drive to check whether the alarm occurs.</p> <p>C. After the B-step operation, the drive still alarms, please try to restore the factory settings, then power off for 30s, and then restart the drive. If the drive still alarms, please contact the manufacturer for after-sales or replacement. If there is no alarm, please reset the parameters and continue to use it again.</p>
AL.101	<p>Parameter saving error</p> <p>A. Appears during parameter saving, generally due to abnormal communication of EEPROM chip, please completely power off the drive 30s, then restart the drive and carry out parameter save test, if there is still a warning, please contact the manufacturer after-sales or replacement.</p>
AL.103	<p>The drive program is running abnormally</p> <p>A. The drive program is running abnormally, please contact the manufacturer for after-sales service.</p>
AL.105	<p>Drive parameters do not match</p> <p>A. Drive P00.34 parameter setting is abnormal, please set this parameter correctly according to the motor model, this parameter is generally 1/ 2.</p>
AL.110 AL.111	<p>AL.110: Drive IPM module overcurrent</p> <p>AL.111: Drive ADC overcurrent</p> <p>A. Whether the motor collides or not causes a blockage</p> <p>B. Motor P06.00, P06.01, P06.02, P06.28, P06.29 improper settings caused. Try to restore the drive parameters and restart to see if the warning still exists. If a warning still appears, please contact the manufacturer for after-sales service.</p> <p>C. By setting the P05.04 parameter, try to reduce the overload multiple of the drive to test whether there is an alarm.</p>

<p>AL.112</p> <p>AL.113</p>	<p>AL.112: Motor command overload</p> <p>AL.113: Motor overheating</p> <p>A. Check if the motor is colliding causing a blockage</p> <p>B. Check whether the encoder cable is connected correctly, e.g. the motor encoder cable does not correspond to the correct connection when multi-axis</p> <p>C. Monitor the drive d03.tF to see the running torque of the motor, and judge whether it is caused by long time overload.</p>
<p>AL.114</p>	<p>Drive IPM module over temperature</p> <p>A. Check the drive housing temperature and ventilation cooling conditions</p> <p>B. Check that the drive fan is spinning properly</p>
<p>AL.115</p>	<p>Drive internal voltage error</p> <p>A. The internal voltage failure of the drive is generally caused by the internal hardware of the drive, please contact the manufacturer for after-sales service.</p>
<p>AL.120</p>	<p>Drive Encoder Interference</p> <p>A. Please check whether the motor PE cable connection is reliable</p> <p>B. Check that the encoder plug is connected reliably</p> <p>C. Replace the drive to check whether the fault is caused by the motor encoder</p>
<p>AL.121</p>	<p>Encoder communication error</p> <p>A. The fault occurs when power-up, generally will alarm AL.170 at the same time, please check that the encoder extension cord connection is reliable.</p> <p>B. If the drive simply alarms AL.121, usually caused by a faulty encoder, replace the motor.</p>
<p>AL.123</p>	<p>Encoder CRC check failure</p>
<p>AL.124</p>	<p>Encoder Z-phase signal failure</p>
<p>AL.125</p>	<p>Encoder counting failure</p>
<p>AL.126</p>	<p>Encoder disconnection fault</p> <p>A. Check that the encoder cable is reliably connected</p>
<p>AL.127</p>	<p>Encoder failure</p> <p>A. Appears during power-on initialization, the incremental encoder reads the Hall signal incorrectly when power-on, and the communication encoder shows that the drive cannot communicate with the encoder.</p> <p>B. Please check that the encoder cable connection is reliable</p>
<p>AL.128</p>	<p>Encoder type setting error</p> <p>A. Check that the P00.34 parameter value is set correctly</p>
<p>AL.129</p>	<p>Encoder data receiving timeout</p>
<p>AL.140</p>	<p>Position error overflow</p>
<p>AL.150</p>	<p>Braking resistance parameter setting is too small</p>

AL.160	<p>FPGA parameter initialization error</p> <p>A. It appears when the drive is powering on and initializing, power off the drive for 30s, then restart it to see if it still alarms, if it still alarms, please replace the drive.</p>
AL.161	<p>The program detected an SPI communication error</p> <p>A. Update the drive and contact the manufacturer for after-sales service.</p>
AL.162	Read encoder EEPROM fault
AL.163	Save the encoder EEPROM fault
AL.164	<p>Encoder data is incorrect</p> <p>A. It appears during power-on initialization, because the encoder has not been calibrated, please contact the manufacturer for after-sales service.</p>
AL.165	<p>Encoder data is incorrect</p> <p>A. When the initialization of power-on, the check and error of the encoder is caused, please power off and restart after 30s, if it still alarms, please contact the manufacturer for after-sales or replace the motor.</p>
AL.166	Write encoder EEPROM failure
AL.167	Write encoder EEPROM failure (read back for verification).
AL.168	Read encoder EEPROM failure
AL.169	Read encoder EEPROM failure
AL.170	<p>Read encoder EEPROM failure</p> <p>A. When power-on initialization occurs, generally due to the encoder extension cable, please check that the extension cable is connected correctly.</p>
AL.171	<p>FPGA initialization error</p> <p>A. It appears during power-on initialization and is caused by abnormal communication between DSP and FPGA.</p>
AL.200	<p>Control mode setting error</p> <p>A. Please check the P01.00 parameter setting value, whether it meets the requirements of the manual, or contact the manufacturer.</p>
AL.201	<p>Position command source setting error</p> <p>A. Please check whether the P03.00 parameter setting value meets the requirements of the manual, or contact the manufacturer.</p>
AL.202	<p>Speed command source setting error</p> <p>A. Please check the P04.00 parameter setting value, whether it meets the requirements of the manual, or contact the manufacturer.</p>
AL.203	<p>Torque command source setting error</p> <p>A. Please check whether the parameter setting values of P05.00, P05.01 and P05.02 meet the requirements of the manual or contact the manufacturer.</p>

AL.210	<p>Drive bus voltage is high</p> <p>A. Please plug in the brake resistance or check the quality of the brake resistance and whether the resistance value is appropriate.</p> <p>B. Please check whether the AC input power is too high and the drive input power requirement is below 260VAC.</p>
AL.211	<p>Drive bus voltage is low</p> <p>A. Please check whether the AC input power is indeed too low and the drive input power requirement is below 170VAC.</p> <p>B. Replace with a new drive to check if the drive is damaged.</p>
AL.212	<p>Driver bus voltage is high</p> <p>A. It occurs when the bus voltage of the driver is momentarily higher than the alarm threshold.</p> <p>B. Please plug in the brake resistance or check the quality of the brake resistance and whether the resistance value is appropriate.</p> <p>C. Please check whether the AC input power is too high and the drive input power requirement is below 260VAC.</p>
AL.213	<p>Torque-limited alarm output</p>
AL.220	<p>Encoder Battery Warning</p> <p>A. When power-on initialization occurs, the battery voltage is less than 3.3V caused, please replace the battery in time.</p> <p>B. Use the AF.CEN function to clear the alarm</p>
AL.221	<p>Encoder battery failure</p> <p>A. The current encoder battery voltage is lower than 2.8V, please replace the battery</p> <p>B. The encoder battery is disconnected from the encoder.</p> <p>C. Use the AF.CEE function to clear the alarm</p> <p>D. When this alarm occurs, the multi-turn encoder data of the drive is already incorrect, and the zero point needs to be reset</p>
AL.222	<p>Encoder multi-turn data alarm</p> <p>A. It occurs during power-on initialization, usually due to the previous disconnection of the encoder battery and the encoder.</p> <p>B. The battery voltage is too low or the battery cable is abnormal</p> <p>C. Use the AF.CEN function to clear the alarm</p> <p>D. When this alarm occurs, the multi-turn encoder data of the drive is already incorrect, and the zero point needs to be reset</p>
AL.230	<p>Overspeed alarm</p>

AL.231	<p>The speed regulator output is saturated</p> <p>A. Check if the crash is caused</p> <p>B. Check that the P06.00, P06.01 parameters are set correctly</p> <p>C. Check that the power cable and the encoder extension cable are properly connected</p>
AL.240	<p>Location is out of tolerance</p> <p>A. Check that the power cable is properly connected</p> <p>B. Check that the electronic gear ratio parameters are set correctly</p> <p>C. Check that the frequency of the pulse input exceeds the maximum speed of the motor</p>
AL.250	<p>No braking feedback</p> <p>A. The brake feedback circuit of the drive is abnormal, replace the drive or contact the after-sales.</p>
AL.251	<p>Brake timeout</p> <p>A. Please connect the braking resistor or check whether the resistance of the braking resistor is normal</p> <p>B. Check that the input AC voltage is within the operating voltage range of the driver calibration</p>
AL.252	<p>Limit input abnormal</p> <p>A. Because the positive and negative limits take effect at the same time, please check the limit sensor and its input port polarity settings</p>
AL.253	<p>braking voltage setting value is too large</p> <p>A. Please check whether the parameter setting value of P01.27 meets the requirements of the manual</p>
AL.260	Analog input channel 1 zero drift setting is abnormal
AL.261	Analog input channel 2 zero drift setting is abnormal